



बैंक ऑफ़ बड़ौदा *Bank of Baroda*



TENDER FOR CIVIL, INTERIOR/FURNISHING, ELECTRICAL AND AIRCONDITIONING WORK FOR BANK OF BARODA, UPLETA BRANCH, UPLETA, GUJARAT

OWNER:

The Regional Manager,
Bank Of Baroda,
Rajkot Region,
M.G. Road,
Near Head Post Office,
Rajkot -360001.

ARCHITECT:

Ar. Anil vadgama,
210, nakshatra II commercial complex,
Opp. Kkv hall,
150 feet wide ring road,
Rajkot - 360005
Mobile: 9824167971

Mandatory information required for Prequalification of the bidder for Civil, Interior/Furnishing, Electrical and Airconditioning work for Bank of Baroda, Upleta Branch, Upleta.

1. Name of the firm :-
2. Address (Head Office) :-
 - Telephone No. :-
 - Office :-
 - Residence :-
 - Mobile :-
 - Fax :-
 - E – Mail :-
3. Address (Local Office) :-
 - Telephone No. :-
 - Office :-
 - Residence :-
 - Mobile :-
 - Fax :-
 - E – Mail :-
4. Whether proprietary/partnership/ Pvt. Ltd. / Public Ltd. (certificate of registration / partnership deed to be enclosed) :-
5. Name of the Proprietor, Partners, Directors :-
 - I)
 - II)
6. Year of establishment :-
7. Registration with Tax Authorities :-
 - I) Income-tax (PAN) No. :-
 - II) GST no. :-
 - III) TIN / VAT No. :-

(Copies of certificates of registration with relevant authorities to be enclosed)

8. Names of the Bankers with address & telephone numbers:
 - I)
 - II)

9. Enclose solvency certificate of the amount :-
Note: The solvency certificate should be addressed to Bank Of Baroda or Any other and not older than six months from the date of advertisement.
10. Furnish copies of audited balance- :
 Sheet and Profit & Loss A/C. for the last 3 years. (CA certified)
11. Registration/Empanelment with Govt. / Public Sector / Banks :-
 (certificates of Registration/Empanelment to be enclosed)

Name of Organization	Year since Empanelled

12. Give details if at present involved in litigation in similar type of contracts:

S.r No.	Name of project	Name of Employer	Nature of Work	Work order dated	Date of Completion Of work	Value Rs.

13. Details of civil suit, if any, that arose :-
during execution of contract in the
past 10 years.
14. Specify maximum value of single :-
value project executed during the
last three years.
15. Name & relation, if any, with the staff :-
member of Bank Of Baroda.
16. Details of work executed during the :-
last 3 years

Type of work	Work Executed For (Name Of the Institution / Body)	Nature of Work (in Brief)	Location	Value Rs.	Duration of Work With Date of commence And completion		If work left Incomplete Or terminate (give reasons)

Note: Copies of work orders along with self attested copies of relevant TDS certificate, satisfactory completion certificate obtained from the client shall be enclosed.

17. Details of work on hand (photo copies of performance certificate, work orders issued by valued clients, preferably Banks, Govt., and Semi-Govt. Bodies should be enclosed).

Type of Work	Work executed For (name of The institution/ Body)	Nature of Work (in Brief)	Location	Value Rs.	Duration of Work, Stipulated Time	Present Stage of Work

18. LIST OF NAME/S OF PROPRIETOR / PARTNERS & EMPLOYEES :-

Name	qualification	experience	Perticulars of Work done	Employed in Your firm since	Value of work done

19. Turnover in last 3 years:-

Sr. No.	Year	Turnover (Rs. In Lacs)	Income tax paid	Vat paid	Service tax paid
1					
2					
3					

MINIMUM ELIGIBLE CRITERIA

Contractor should have completed one furnishing works Rs. 20.00 Lakhs or Two Works of 10.00 Lakhs for Banks / PSUs / FIs enclose certificate form employers. (In Last 3 years)

I/We confirm that to the best of our knowledge this information is authentic and accept that any deliberate concealment will amount to disqualification at any stage.

Seal and Signature of the Bidder/s.

Date:

Place:

Please Note : Bank has a right to prequalify / disqualify any application without giving any reason to any applicants.

Important Note:

- Contractor shall submit prequalification documents in the same sequence as in technical Bid. If details are not provided in the same sequence Tender may be disqualified.
- Price Bid shall not be modified or altered and shall be hand written with signature and seal (If bid is altered the tender may be disqualified)

Enclosures



**THE REGIONAL MANAGER,
BANK OF BARODA,
RAJKOT REGION,
M.G. ROAD,
NEAR HEAD POST OFFICE,
RAJKOT -360001.**

Bank of Baroda, **Rajkot Region**, invites sealed tender cum quotations from contractors for proposed Civil, Interior/Furnishing, Electrical, Air-conditioning work of “**Bank of Baroda, Upleta Branch, Upleta.**”

भाग / **PART – I** और भाग /**PART – II**,
तकनीकी बोली और मूल्य बोली, **TECHNICAL BID & PRICE BID**,
(सीलबन्द लिफाफे में जमा करना होगा), (**To be submitted in Sealed Envelope**),

निविदा शुरू होने की तारीख / Start date of Tender - **15.02.2025**
निविदा जमा करने की अंतिम तिथि/Last date of submission of Tender- **07.03.2025 3:00 PM**

तकनीकी और मूल्य बोलियां खोली जाएगी / Date of Opening of Technical & Price Bids:
07.03.2025, 3.30 PM

**THE REGIONAL MANAGER,
BANK OF BARODA,
RAJKOT REGION,
M.G. ROAD,
NEAR HEAD POST OFFICE,
RAJKOT -360001.**

NOTICE INVITING TENDER

Bank of Baroda, **Rajkot Region**, invites sealed tender cum quotations from contractors for proposed Civil, Interior/Furnishing, Electric, Air-conditioning work of **“Bank of Baroda, Upleta Branch, Upleta.”**

Details of tenders are as under:

- Name of Work: **Proposed Civil, Interior/Furnishing, Electric, Air-conditioning Works of Bank of Baroda, Upleta Branch, Upleta.**
- Time allowed for completion : **30 days**
- Earnest Money Deposit : **NIL**
- Security Deposit for Defect's Liability Period : **5% of contract value**
- Cost of Tender documents : **NIL**
- Availability of Tender Documents : Bank Websites from **15/02/2025** to **07/03/2025** during Office Hours i.e. 10 am to 5 PM except on Sundays and Holidays.
- Last date and time of receipt of tenders : **Up to 03:00 P.M. on 07.03.2025**
- Address at which the tenders are to be submitted: **Bank of Baroda, Regional Office, Rajkot Region, M.G. road, Near Head Post Office, Rajkot 360001.**
- **Tenders to be dropped in the tender box placed in the above office.**
- Date and time of opening of tender: Technical Bid & Price Bid – **07.03.2025 AT 3.30 PM.**
- Place of opening tenders: **Bank of Baroda, Regional Office, Rajkot Region, M.G. road, Near Head Post Office, Rajkot 360001.**
- Defects Liability Period: 12 Months from the date of completion certificate issued by the Bank Engineer/Bank's Panel Architect.
- Validity of offer: 90 days from the date of opening of price bid of tender.
- Liquidated Damages: 0.5% per week subject to maximum of 10% of the accepted contract sum.
- **Eligible Criteria:** Completed one furnishing works Rs. 20.00 Lakhs or Two Works of 10.00 Lakhs for Banks / PSUs / FIs enclose certificate form employers. (In Last 3 years)
- Tender will be issued in two parts: Part I- Containing terms and conditions, specifications etc. and Part II - Bill of Quantity which shall have to be filled up as the Price Bid.
- Tender including both parts shall have to be submitted in Single Sealed Cover (envelop) to above referred address super-scribing **“Tender for Proposed Civil, Interior/Furnishing, Electric, Air-conditioning Work for Upleta Branch, Upleta.”**
- Cover- I: Shall contain tender document signed and sealed on each page by authorized signatory. It shall also contain the following :
 - a. List of deviation, if any, in commercial terms & condition, in technical specification.
 - b. Any other technical information the tenderer wishes to furnish.
 - c. Technical Literature/Catalogues of the equipment being offered along with related drawings.
- Cover-II: Shall contain the offered price in INDIAN RUPEES only with detailed break up of price as per Bill of Quantity duly filled. Other than an unconditional general rebate, no other condition stipulated in Cover-II shall be accepted.
- Both the sealed covers shall be put in one single envelop and sealed duly super-

scribing **“Tender for Proposed Civil, Interior/Furnishing, Electric, Air-conditioning Work for Upleta Branch, Upleta.”**

- The envelope containing both the bids must be addressed to above referred address:
- Sealed tender including price bid will be opened on **07.03.2025 at 3:30 PM** in the presence of Tenderers who desire to attend. In case attended by representatives of the tenderers, representatives shall carry with them such an authorization letter from the company/contractor firm. In order to expedite the process the representatives deputed by the tenderers at the time of tender opening should also be authorized to take the decision on behalf of the tenderers.
- Delays in submission of any document arising out of the postal irregularities/or any other reason at any stage will not be considered. Also the Bank will not be responsible for damage to tender in transit in case of postal/courier delivery. Late tenders will not be accepted.
- In case the date of opening of tenders is declared as a holiday, the tenders will be opened on the next working day at the same time. All bidders are requested to remain present at time of opening of tender.
- Bank reserves its right to accept or reject any/all the tenders without assigning any reason whatsoever.
- Any Corrigendum/addendum, if any, shall be intimated via email to the contractor **separately**. Contractors shall keep checking their email during the course of this Tender process.
- Mobilization Advance: NIL.
- All liasioning/ licensing/ compliance/ approvals work for the statutory requirement shall be in the scope of the Vendor.

For and behalf of Bank of Baroda

**Regional Manager
Rajkot Region
Rajkot**

FORM OF TENDER

**TO,
 THE REGIONAL MANAGER,
 BANK OF BARODA,
 RAJKOT REGIONAL OFFICE,
 M.G. ROAD,
 NEAR HEAD POST OFFICE,
 RAJKOT -360001.**

Dear Sir,

Having examined the drawings, specifications, designs and bill of quantities, relating to the works specified in the memorandum hereinafter set out and having examined the site of the works specified in the said memorandum and having acquired the requisite information relating thereto as affecting the tender, I/we hereby offer to execute the works specified in the said memorandum at the rates mentioned in the attached bill of quantities and in accordance in all respects with the specifications, designs, drawings and instructions in writing referred to in condition of tender, appendix to the form of tender, articles of agreement, conditions of contract, bill of quantities and with such materials as are provided for, by, and in all other respects in accordance with such conditions so far as they may be applicable.

Memorandum

Description of works	Proposed Civil, Interior/Furnishing, Electrical, Air-conditioning Works of Bank of Baroda, Upleta Branch, Upleta.
Earnest money deposit	NIL
Security deposit	Total 5% of the contract value consisting of Initial Security Deposit 2% of contract value including the Earnest Money Deposit & retention amount @ 08% to be deducted from the running bills subject to maximum of 5% of the contract value including Initial Security Deposit.
Time allowed for completion	30 days from the date of commencement

Should this tender be accepted, I/we hereby agree to abide by and fulfill the terms and provisions of the said conditions of contract annexed hereto so far as they may be applicable or in default thereof to forfeit and pay to **BANK OF BARODA** the amount mentioned in the said conditions.

All information and documents as required to be submitted with the tenders.

Our bankers are

The names of partners of our firm are

Name of the partner(s) of the firm authorize to sign:

Name of the persons having power of attorney to sign the contract (certified true copy of the power of attorney should be attached).

Yours faithfully,

Place:

Signature of contractor

Date:

Signature and addresses of witnesses



APPENDIX TO FORM OF TENDER

Item	Reference No	description
Contract value	As per GCC	Total value of the tender as accepted by the employer. The rate quoted shall be firm and shall include all costs, allowances, taxes, levies etc excluding GST as well as all other costs like transportation, handling etc.
Date of commencement	37 of GCC	-07- days from the date of work order or the date of instruction for taking possession of site, whichever is later.
Time of completion	39 of GCC	30 days from the date of Commencement.
Liquidated damages for delay	43 of GCC	0.5% per week subject to maximum of 10% of the accepted contract sum
Defect liability period	32 of GCC	12 months from the date of completion certificate issued by the Bank.
Earnest Money deposit		Nil
Insurance	36 of GCC	As per clause 36 of GCC
Minimum value of RA bills	47(b) of GCC	No Interim Bill considered.
Payment of RA bill	47(c) of GCC	NA
Initial Security Deposit		The successful tenderer will have to submit a sum equivalent to 2% of contract value less EMD through submit online through NEFT/RTGS as given account details in NIT within a period of 04 days of placement of work order.
Submission of final bill	47(e) of GCC	Within 15 days from the date of final completion as certified by the Engineer.
Payment of final bill	47 (i) of GCC	Within 20 days from the date of submission of the final bill by the contractor
Retention Money		8% of gross value of work in Running bills to a maximum of Balance Security Deposit
Security Deposit		Total security deposit shall be 5% of contract value. Out of this 2% of contract value is in the form of Initial Security Deposit plus EMD. Balance 3% shall be deducted from the running account bill of the work at the rate of 8% of the respective running account bill i.e. deduction from each running bill account will be 8% till total 3% of contract value is reached. 50% of the total security shall be paid to the contractors on the basis of Bank Engineer's / Architect's certification on virtual completion of work. The balance 50% would be paid to the contractors without interest within 30 days after the end of the defect liability period provided the contractor has satisfactorily attended to all defects in accordance with the conditions of contract including site clearance. <u>No interest shall be paid to the amount retained by the Bank as Security Deposit.</u>
Price variation	28 of GCC	Firm price. No escalation
Signing of Contract Documents		The successful tenderer shall be bound to implement the contract by signing an agreement and conditions of contract attached herewith within 07 days from the receipt of intimation of acceptance of his tender by the Bank. However, the written acceptance of the tender by the Bank Engineers on behalf of the Bank will constitute a binding agreement between the Bank and successful tenderer whether such formal agreement is subsequently entered into or not.
AMC (optional)		AMC is optional and binding on contractor for minimum period of 05 years. Half yearly satisfactory report shall be produced by contractor during DLP/AMC. Payment for AMC will be made half yearly on providing satisfactory services.

ARTICLES OF AGREEMENT

(Duly Notarized)

ARTICLE OF AGREEMENT made thisday of **TWO THOUSAND Twenty Four (2024)** BETWEEN the **BANK OF BARODA**, a company incorporated and registered under the Companies Act, 1956 and having its office at **Bank of Baroda, Rajkot Region, M.G. Road, Near Head Post Office, Rajkot -360001.**, hereinafter called "Employer" (which expression shall include its successors and assigns wherever the context or meaning shall so require or permit, of the one part and (Hereinafter called the "Contractor") (Which expression shall include its successors and assigns wherever the context or meaning shall so require or permit) of the other part.

WHEREAS the Employer is desirous of carryout the **Proposed Civil, Interior/Furnishing, Electric, Air-conditioning Works at Bank of Baroda, Upleta Branch, Upleta** as mentioned, and has got drawings, specifications and the bill of quantities prepared by their Architects/Consultants which have been signed or on behalf of the parties hereto.

AND WHEREAS the Contractor has agreed to execute upon and subject to the conditions set forth herein and to the conditions set forth in the special conditions and in the Bill of Quantities and conditions of contract (all of which are collectively hereinafter referred to as "The said terms & conditions", the works, shown upon the said drawings and/or described" in the said specifications and included in the said bill of quantities at the respective rates therein set forth amounting to the sum as therein arrived at or such other sum as shall become payable there under (herein after referred to as the said "contract value").

NOW IT IS HEREBY AGREED AS FOLLOWS:

- 01 In consideration of the said Contract Value to be paid at the times and in the manner set forth in the said terms & conditions; the contractor shall upon and subject to the said terms & conditions execute and complete the works shown on the said drawings, and described in the specifications and/or bill of quantities.
- 02 The Employer shall pay the contractor The Said Contract Value or such other sum as shall become payable at times and in the manner specified in the said terms & conditions.
- 03 The said terms & conditions and Appendices thereto shall be read and construed as forming part of this Agreement and the parties hereto shall respectively abide by submit themselves to the said terms & conditions and perform the agreements on their part respectively in the said terms & conditions contained.
- 04 The contract is neither a fixed lump-sum a contract nor a piece work contract but is a contract to carry out the work in respect of the entire work as defined in the contract documents to be paid for according to actual measured quantities at the rates contain in the bill of quantities or as provided in the said contract documents.
- 05 The contract shall afford every reasonable facility for the carrying out of all works relating to DG Sets in the manner laid down in the said conditions, and shall make good any damages done to walls, floors, etc. after the completion of such works.
- 06 The Employer reserves to itself the right of altering the Drawings and nature of the work by adding to or omitting any items of work or having portions of the same carried out without prejudice to this Contract.
- 07 Time shall be considered as the essence of this Contract and the Contractor hereby agrees to commence the work from date of Letter of Acceptance and to complete the entire work within **30 days** subject nevertheless to the provision for extension of time.
- 08 All payments by the Employer under this contract will be made only at **Rajkot**.
- 09 All disputes arising out of or in any connected with this agreement shall be deemed to have arisen at **Rajkot** and only court in **Rajkot** shall have jurisdiction to determine the same.
10. That the several parts of this Contract have been read by the Contractor and fully understood by the Contractor. The Contractor shall not be entitled for the payment for the quantities beyond the tendered quantities unless ordered for by specific written instructions from the engineer.



IN WITNESS WHEREOF THE Employer and the Contractor have set their respective hands to these presents and two duplicates hereof the day and year first hereinabove written. (If the contractor is a partnership or an individual).

IN WITNESS WHEREOF the Employer has set its hand to these presents through its duly authorized official and the Contractor has caused its common seal of to be affixed hereunto and the said two duplicates/has caused these presents and the said two duplicates hereof to be executed on its behalf, the day and year first hereinabove written (If the Contractor is a company).

Signature Clause

SIGNED & DELIVERED by the BANK OF BARODA by the hand of Shri _____ (Name and Designation)

in the presence of (1) _____ Address _____

(2) _____ Address _____

Witness

SIGNED AND DELIVERED BY _____ in the presence of

(1) _____ Address _____

(2) _____ Address _____

(2) _____ Address _____

If the party is a partnership firm of an individual should be signed by all or on behalf of all partners.

Witness

THE COMMON SEAL OF _____

Was hereunto affixed pursuant to the resolutions passed by its Board of Directors at the meeting held on _____ in the presence of

(1) _____

(2) _____

Directors who have signed these presence in token thereof in the presence of

(1) _____

(2) _____

If the contractor signs under its common seal the signature clause should tally with the sealing clause in the Articles of Association.

SIGNED AND DELIVERED by _____ the contractor by the hand of _____ Shri

_____ And duly constituted attorney

If the Contractor is signing by the hand of power of attorney whether a company or individual.



GENERAL CONDITIONS OF CONTRACT

01. Definitions & Interpretations

In construing these conditions, the Specifications, Bill of quantities and Contract Agreement etc. the following words shall have the meaning herein assigned to them except where the subject or context otherwise requires.

01a "Employer" / "Owner" means - **The Regional Manager, Bank of Baroda, Rajkot Region, M.G. Road, Near Head Post Office, Rajkot - 360001** and includes the Employer's representatives, successors and assigns.

01b "Architect" means project Architect

01c "Engineer" means "Bank's Engineer" or their authority's nominees and representatives or such other firm / persons, as shall be nominated by the Employer.

CONTRACTOR shall mean: -

In the case of a Partnership firm:- _____ and _____ trading as partners in the name and style of _____ & having a place of business at _____ and shall include the partners for the time being of the said firm and the legal representatives of a deceased partner.

In the case of individual Contractor:- Shri _____ trading in the name and style of _____ and shall include his heirs, successors and legal successors and legal representatives.

In the case of Company:- _____ a company incorporated under _____ 2022 and having its registered office at _____ and office at _____ and shall include its successors and assignee.

"Site" shall mean the site of the contract works including any building and erections thereon and any other land (inclusively) as aforesaid allotted by the Employer for the Contractor's use.

"Contract" shall mean the following documents, all duly signed, collective in that order of precedence.

- a. Articles of Agreement
- b. Letter of acceptance of tender / award of work
- c. Special Conditions of Contract
- d. General conditions of contract including clarifications / conditions accepted after the Pre-bid Meeting.
- e. Drawings
- f. Specifications
- g. Bill of Quantities

"Notice in writing" or "written notice" shall mean a notice in written, typed or printed characters sent (unless delivered personally or otherwise proved to have been received) by registered post to the last known private or business address or registered office of the addressee and shall be deemed to have been received when in the ordinary course of post it would have been delivered.

"Act of Insolvency" shall mean any Act of Insolvency as defined by the Presidency Towns insolvency Act, or the Provincial Insolvency Act or any Act amending such original.

"Net Prices" : If in arriving at the contract amount, the Contractor shall have added to or deducted from the total amount of the items in the Tender any sum, either as a percentage or other wise, then the net price of any item in the tender shall be the sum arrived at by adding to or deducting from the actual figure appearing in the Tender as the price of that item and similar percentage or proportionate sum provided always that in determining the percentage or proportion of the sum so added or deducted by the Contractor, the total amount of any Prime Cost items and provisional sums of money shall be deducted from the total amount of the tender. The expression "net rates" or "net prices" when used with reference to the contract or accounts shall be held to mean rates or prices so arrived at.

"Works" means the permanent works described in the "Scope of Work" and / or to be executed in accordance with the Contract and includes materials, apparatus, equipment, temporary supports, fittings, and things of all kinds to be provided, the obligations of the Contractor hereunder and work to be done by the Contractor under the contract.

"Drawings" means the drawings prepared by the Architects and issued by the Engineer and referred to in the Specifications and any modification of such drawings and such other drawings as may be issued by the Engineer from time to time.

"Bill of Quantities" means the Schedule and Quantities of items, materials & rates, summaries, etc. as finally accepted.

"Specification" means the specifications given in these documents including relevant Indian standard specification where so required and where such a specification is not available, the specification approved by the Architect.

"Temporary Works" means all temporary works of every kind required in or about the execution, completion or maintenance of the works.

"Materials" means the materials, apparatus, equipments, fittings, fixtures and all such other material, which are incorporated in the 'work'.

"Virtual Completion of the Works" means the completion of the whole of the works substantially in all respects as evidenced by issuance of a Certificate of Virtual Completion by the Engineer in pursuance of above Clause of the General Conditions of Contract.

"Period of Maintenance / Defect Liability Period" shall mean the period of 365 days (Three hundred sixty five) calculated from the date of virtual completion of the works as certified by the Engineer.

"Urgent Works" means any urgent works, which in the opinion of the Engineer / Employer becomes necessary at the time of execution and / or during the progress of work to obviate any risk of accident or failure or to obviate any risk of damage to the structure or services or required to accelerate the progress of work for which becomes necessary for safety and security or for any other reason, the Engineer / Employer may find it necessary.

"Market Rate" means the rate as decided by the Engineer / Employer on the basis of cost of materials at site inclusive of any tax, duty, octroi etc. at the time of execution of work.

"Approved" means approved in writing; "Approval" means approval in writing.

"Month" means calendar month.

"Week" means seven consecutive calendar days.

"Day" means a calendar day beginning and ending at 00 Hours and 24 hours respectively,

"Contract Value" means the total value of the tender as accepted by the Employer.

Interpretations / Marginal Note / Heading / Catch Lines.

The Marginal Notes, Headings and in the catch lines hereto and in the annexure hereto are meant only for convenience of reference and shall not in any way be taken into account in the interpretation of these presents and the annexure hereto. The Contractor will have to carry out and complete the said work in every respect in accordance with this contract.

Words imparting the singular only also include the plural and vice versa where the context requires.

02. **Language(s)**

The language in which the Contract documents shall be drawn up shall be English only.

03. **Errors, Omissions and Discrepancies**

3a In case of errors, omissions and / or disagreement between written and scaled dimensions on the drawings or between the drawings and specifications etc., the following order of precedence shall apply:

3a1 Between scaled and written dimension (or description) on a drawing, the latter shall be adopted.

3a2 Between the written or shown description or dimensions in the drawings and the corresponding one in the specification the former shall be taken as correct.

3a3 Between the written description of the item in the specifications & descriptions in the Bill of Quantities of the same item, the former shall be adopted.

3a4 In case of difference between the rates written in figures and words, the rate in words shall prevail.

3a5 Between the duplicate / subsequent copies of the tender and original tender, the original tender shall be taken as correct.

3a6 In all cases of omissions and / or doubts or discrepancies in any of the items or specifications, a reference shall be made to the Architect whose elucidation; elaboration or decision shall be considered as authentic and binding.

04. Scope of Contract

The Contract comprises the construction, completion and maintenance of the works and except in so far as the Contract otherwise stipulates the provision of all labour, materials, constructional plant, machinery temporary works and everything whether of a temporary or permanent nature required in and for such construction, completion and maintenance so far as necessary for providing the same as specified in or reasonably to be inferred from the Contract.

05a Letter of Acceptance / Award

Before signing of the Contract, the Employer shall issue by registered post or by otherwise depositing at the registered office of the Contractor, Letter of Acceptance / Award to enter into a Contract with the Contractor for the execution of the works in accordance with the contract. Until a formal contract agreement is prepared and executed, the tender documents i.e. Volume I, II, III & set of drawings together with the relevant correspondence exchanged from receipt of the tender to acceptance and together with the Employer's letter of Acceptance / Award shall constitute a binding contract between the parties.

05b Contract Agreement

On receipt of intimation from the Employer of the acceptance of his / their tender, the successful tenderer shall be bound to implement the contract and within seven days thereof, the successful tenderer shall sign an agreement in accordance with the draft agreement.

06. Custody of Drawings & Specifications

The Contract shall be executed in quadruplicate and the Employer, the Architect, the Engineer and the Contractor shall be entitled to one executed copy each for their use. The Contractor on the signing hereof shall be furnished by the Engineer free of cost two copies of all tender Drawings and all further Drawings issued during the progress of the works. Any further copies of such Drawings required by the Contractor shall be obtained by him from the Architect on payment of necessary charges to be fixed by the Architect. The Contractor shall keep one copy of all Drawings at the works site and the Employer / Architect / Engineer shall at all reasonable time have access to the same. Before the issue of the final certificate to the Contractor, he shall forthwith return to the Engineer all Drawings and Specifications.

07. Disruption of Progress

The Contractor shall give adequate but not less than 3 weeks time written notice to the Engineer whenever planning or progress of the Works is likely to be delayed or disrupted unless any further drawing or order, including a direction, instruction or approval, is required to be issued by the Engineer. The notice shall include details of the drawing or order required explaining why and by when it is required and of any delay or disruption likely to be suffered if it is late.

08. Further Drawings and Instructions

The Contractor shall carry out and complete the said work in every respect in accordance with this Contract and with the directions of and to the satisfaction of the Engineer. The Architect / Engineer may in his absolute discretion and from time to time issue further drawings and / or written instructions, details, directions and explanations which are hereafter collectively referred to as "Engineer's / Architect's Instructions" in regard to:-

08a Any discrepancy in the Drawings or between the Bill of Quantities and / or Drawings and / or Specification. BOQ will supercede drawings in case of discrepancy.

08b Removal from the site of any material brought by the Contractor which is rejected by PMC.

08c Removal and / or re-execution of any works executed by the Contractor if found not as per specifications / BOQ.

08d The dismissal from the works of any persons employed thereupon.

08e The opening up for inspection of any work covered up.

08f The amending and making good of any defects under Clause 30 hereof.

The Contractor shall forthwith comply with and duly execute any work comprised such Engineer's / Architect's instructions provided always that verbal instructions, directions and explanations given to the Contractor or his representative upon the works by the Engineer shall, if involving a variation, be confirmed in writing by the Contractor within seven days, and if not dissented from in writing within

a further seven days by the Engineer, such shall be deemed to be Engineer's / Architect's instructions within the scope of the Contract.

09. **VOID**

10. **Contractor's General Responsibilities**

The Contractor shall provide at his cost everything necessary for the proper execution of the works according to the intent and meaning of the Drawings, Bill of Quantities and Specifications taken together with whether the same may or may not be particularly shown or described therein provided that the same can reasonably be inferred there from, and if the Contractor finds any discrepancy in the Drawings or between the Drawings, Bill of Quantities and Specifications, he shall immediately and in writing refer the same to the Engineer who shall decide which is to be followed after consultation with Architect.

The successful tenderer is bound to carry out any items of work necessary for the completion of the job even though such items are not included in the Bill of Quantities and rates. Instructions in respect of such additional items and their quantities will be issued in writing by the Engineer with the prior consent in writing of the Employer.

The Contractor must co-operate with the other contractors appointed by the Employer so that the work shall proceed smoothly to the satisfaction of the Engineer.

The Contractor must bear in mind that all the work shall be carried out strictly in accordance with the Specifications as given in these documents and also in compliance of the requirements of the local public authorities and to the requirements / satisfaction / direction of the Engineer and no deviation on any account will be permitted.

The Contractor shall have to use materials from the makes / manufacturers specified in the list of materials of approved brand and / or manufacture contained in contract documents and as approved by Employer / Architect.

11. **Safety of Site Operations**

The Contractor shall take full responsibility for the safety, stability and adequacy of all site operations and methods of construction including all temporary works, provided that the Contractor shall not be responsible, except as may be expressly provided in the Contract, for the design or specification of the permanent works. The contractor shall maintain safety as per Standard Industrial Safety Code or any other Code approved by the Engineer.

12. **Watching & Lighting**

The Contractor shall in connection with the Works provide and maintain at his own cost adequate lights, guards, fencing, warning signs and watch & ward staff when and where necessary or as directed by the Engineer or as directed by duly constituted authority for the protection of the works or for the safety and convenience of the public or pilferage of materials from site.

13. **Care of Works**

From the commencement to the certified completion of the whole of Works, the contractor shall take full responsibility for the care thereof and of all Temporary Works and in case any damage loss or injury shall happen to the works or to any part thereof or to any Temporary Works from any cause whatsoever the Contractor shall at his own cost repair and make good the same so that on completion, the works shall be in good order and condition and in conformity to every respect with the requirements of the Contract and the Engineer's / Architect's instructions. The Contractor shall also be liable for any damage to the Works occasioned by him including his subcontractors in the course of any operations carried out by him for the purpose of completing any outstanding work and complying with his obligations under Clause 32 hereof. The Contractor shall indemnify the Employer from all risks on this account.

14a. **Contractor's Senior Representative for Execution & Coordination of Works**

The Contractor shall have on site at all times during working hours throughout the course of the Contract at least one competent senior representative who shall be empowered to make decisions binding on the Contractor in respect of all matters likely to arise in connection with the execution & coordination of the Works at site and shall keep the Engineer and the Employer informed at all times about the name and designation of such representative. Contractor's Senior Representative shall have the power to take joint measurement and sign the measurement books / bills.

Any directions, explanations, instructions or notices given by the Engineer to such representative shall be held to be given to the Contractor.

14b Contractor's Employees

The Contractor shall provide and employ after approval from the Engineer on the site in connection with the execution, completion and maintenance of the Works all Engineering staff / technical assistants as are qualified, skilled and experienced in their respective trades, foremen and leading hands as are competent to give proper supervision, ensuring quality & output to the work they are required to supervise, and also such skilled, semi-skilled and unskilled labour as are necessary for the proper and timely execution, completion and maintenance of the works.

14c Removal of Contractor's Employees

The Contractor shall on the direction of the Engineer immediately dismiss from the works any person employed thereon by him who may, in the opinion of the Engineer, be incompetent or misconduct himself and such person shall not be again employed on the works without the permission of the Engineer.

14d Unauthorized Persons

No unauthorized persons are to be allowed on the site. The Contractor shall instruct all such persons to keep out and shall take steps to prevent trespassing.

15. Compliance with Statutes, Regulations, Etc.

The Contractor shall conform to the provisions of any Act of the legislature relating to the works, and to the regulations and bye-laws of any authority, and of any water, electric supply and other companies and / or authorities with whose systems the structure is proposed to be connected, and shall, before making any variations from the Drawings or Specifications that may be necessitated by so regulations, give to the Engineer written notice, specifying the variation proposed to be made and the reason for making it and apply for instructions thereon. In case, the Contractor shall not within ten days of submission of such notice, receive such instructions, he shall proceed with the work conforming to the provisions, regulations, or bye-laws in question, and any variation so necessitated shall be dealt with under Clause 28 thereof.

The Contractor shall bring to the attention of the Engineer all notices required for execution by the said Acts, regulations or bye-laws to be given to any authority and pay to such authority, or to any public office all fees that may be properly chargeable in respect of the works, and lodge the receipts with the Engineer for reimbursement at actual.

16. Setting Out

The Contractor shall set out the works and shall be responsible for the true and perfect setting out of the same and for the correctness of the positions, levels, dimensions, and alignment of all parts thereof. If at any time any error in this respect shall appear during the progress of the works or within the defects liability period the Contractor shall, if so required, at his own expense rectify such error to the satisfaction of the Engineer.

17a Quality of Materials & Workmanship & Test

All materials and workmanship shall be the best of the respective kinds described in the Contract and in accordance with the Engineer's / Architect's instructions and shall be subjected from time to time to such tests as the Engineer may direct at the place of manufacture or fabrication or on the Site or at an approved testing laboratory.

The Contractor shall upon the instruction of the Engineer / Engineer's / Architect's Representative furnish him with documentation to prove that the materials & goods comply with the requirements of contract and for requirement stated above. The Engineer may issue instruction in regard to removal of material from site or any work, if these are not in accordance with the Contract. The Contractor shall provide such assistance instruments, machinery, labour and materials as are normally required for examining, measuring, sampling and testing any material or part of work before incorporation in the works for testing as may be selected and required by the Engineer / Engineer's / Architect's Representative.

17b Samples

All samples of adequate numbers, sizes, shades & pattern as per specification shall be supplied by the Contractor without any extra charge. Apart from adhering to any special provision made in the specifications regarding submission of samples the contractor shall within 7 days of his receipt of Letter

of Acceptance, provide to the Architect samples along with the detailed literature of all materials he proposes to use in the work irrespective of the fact that a specific make / material might have been stipulated. If certain items proposed to be used are of such nature that samples cannot be presented or prepared at the site, detailed literature / test certificate of the same shall be provided to the satisfaction of the Architect / Engineer. Before submitting the samples / literature, the contractor shall satisfy himself that the material / equipment for which he is submitting the samples / literature meet with the requirement of the specification. The Architect / Engineer shall check the samples and give his comments and / or approval to the same. Only when the samples are approved in writing by the Architect / Engineer, the contractor shall proceed with the procurement and installation of the particular material / equipment. The approved samples shall be signed by the Architect / Engineer for identification and shall be kept on record at site office until the completion and acceptance of the work and shall be available at the site for inspection / comparison at any time. The contractor shall keep with him a duplicate of such samples to enable him to process the matter.

For items of work where the samples are to be made at the site, the same procedure shall be followed. All such samples shall be prepared at a place where it can be left undisturbed until the completion of the project.

The Architect / Engineer shall communicate their comments / approval to the Contractor to the samples at his earliest convenience. Any delay that might occur in approving of the samples for reasons of its not meeting with the specifications or other discrepancies, inadequacy in furnishing samples of best qualities from various manufacturers and such other aspects causing delay on the approval of the materials / equipments, etc. shall be to the account of the contractor. In this respect the decision of the Engineer shall be final.

On delivery of the supplies of materials / equipment for permanent works at the site, the contractor shall specifically arrange to get the supply inspected by the Engineer and compared with the approved sample and his specific approval obtained before using the same in the work.

17c Cost of Tests

The cost of making any test shall be borne by the Contractor if such test is intended by or provided for in the Specification or Bill of Quantities.

17d Costs of Tests not provided for, etc.

If any test is ordered by the Engineer which is either

- (a) not so intended by or provided for or
- (b) (in the cases above mentioned) is not so particularized, or

(c) though so intended or provided for but ordered by the Engineer to be carried out by an independent person at any place other than the site or the place of manufacture of fabrication of the materials tested or any Government / approved Laboratory, then the cost of such test shall be borne by the Contractor.

18. Absence of Specification

If the specifications do not contain particulars of materials and works which are obviously necessary for the proper completion of the works, and the intention to include, which is inferred, all such materials and works shall be supplied and executed by the Contractor without extra charge. If the Contractor requires additional information, he shall, in pursuance of Clause 7.0 hereof, so request in writing well in advance to commencement of the particular work to the Engineer who will issue such detailed information as necessary within a reasonable time.

19. Obtaining Information Related to Execution of Work

No claim by the contractor for additional payment will be entertained which is consequent upon failure on his part to obtain correct information as to any matter affecting the execution of the works, nor will any misunderstandings or the obtaining of incorrect information or the failure to obtain correct information relieve him from any risks or from the entire responsibility for the fulfillment of the contract.

20. Contractor's Superintendence

The Contractor shall give all necessary personal superintendence during the execution of the works, and as long, thereafter, as the Engineer may consider necessary until the expiry of the "Defects Liability Period" stated hereto.

21. Access for Inspection

The Employer, the Architect, the Engineer and their respective representatives shall at all reasonable times have free access to the work and / or to the workshops, factories or other places where materials are lying or from which they are being obtained and the Contractor shall give to the Employer, the Architect, the Engineer and their representatives every facility necessary for checking measurements, inspection and examination and test of the materials and workmanship. No person not authorized by the Employer or the Architect or the Engineer except the representatives of public authorities shall be allowed on the works at any time.

22a. Examination of Work Before Covering Up

No work shall be covered up or put out of view without the approval of the Engineer and the Contractor shall afford full opportunity for the Engineer to examine and measure any work, which is about to be covered up or put out of view and to examine foundations before permanent work is Placed thereon. The Contractor shall give due notice to the Engineer of any such work or foundations is or are ready or about to be ready for examination and the Engineer shall without unreasonable delay, unless he considers it unnecessary and advises the Contractor accordingly, attend for the purpose of examining and measuring such work or for examining such foundations.

22b Uncovering and making openings

The Contractor shall uncover any part or parts of the Works or make openings in or through the same as the Engineer may from time to time direct and shall reinstate and make good such part or parts to the satisfaction of the Engineer. If any such part or parts have been covered up or put out of view after compliance with the requirements of sub-clause (i) of this Clause and are found to be executed in accordance with the contract the expenses of uncovering, making openings in or through reinstating and making good the same shall be borne by the Employer but in any other case all such expenses shall be borne by the Contractor and shall be recoverable from him by the Employer or may be deducted by the Employer from any monies due or which may become due to the Contractor.

23. Assignment

The whole of the works included in the contract shall be executed by the Contractor and the Contractor shall not directly or indirectly transfer, assign or sublet the contract or any part / share thereof or any interest therein without the prior written consent of the Employer / Architect and no undertaking shall relieve the Contractor from the full and entire responsibility of the contract or from active superintendence of the works during their progress.

24. Quantities

24a The Bill of Quantities (BOQ), unless otherwise stated shall be deemed to have been prepared in accordance with the Indian Standard Method of Measurement and quantities in B.O.Q. are to be considered as estimated and not accurate. The rates quoted shall remain valid for variation of quantity against each individual items to any extent subject to maximum variation of the contract value by $\pm 25\%$. The entire amount paid under Clause 27, 28 hereof and 29 of SCC as well as amounts of prime costs and provisional sums, if any, shall be excluded.

24b Variation Exceeding 25%: The items of work executed in relation to variation exceeding 25% of contract value shall be paid on the basis of provision of above Clause here of.

25. Works to be Measured

The Engineer may from time to time intimate to the Contractor that he requires the works to be measured, and the Contractor shall forthwith attend or send a qualified Representative to assist the Engineer in taking such measurements and calculations and to furnish all particulars or to give all assistance required by any of them.

Should the Contractor not attend or neglect or omit to send such Representative, then the measurement taken by the Engineer or a person approved by him shall be taken to be correct measurements of the works. Such measurements shall be taken in accordance with the Mode of Measurements detailed in the Specifications.

The Engineer shall take joint measurements with the contractor and the measurements shall be entered in the measurement book / sheet by the Engineer's / Architect's representative.

The Contractor or his Representative may at the time of measurement take such notes and measurements as he may require.

All authorized extra works, omissions and all variations made without the Engineer's / Architect's knowledge, but subsequently sanctioned by him in writing (with the prior approval in writing of the Employer) shall be included in such measurements.

26. Claims

The Contractor shall send to the Engineer once in every month an account giving particulars as complete and fully detailed as required of all claims for any additional expenses claims, to which the Contractor may consider himself entitled and of all extra or additional / substituted work ordered by the Engineer which he has executed during the preceding month subject of provisions under relevant clauses of contract hereof, and no claim for payment for any such work will be considered which has not been included in such particulars. Provided always that the Engineer shall be entitled to authorize payment to be made for any such work notwithstanding the Contractor's failure to comply with this condition, if the Contractor has, at the earliest practicable opportunity notified the Engineer in writing that he intends to make a claim for such work and thereafter send complete and detailed particulars of the claim to the Engineer as directed by the Engineer but not later than 10 days from the date of notification of his claim.

27. Variations

No alteration, omission or variation ordered in writing by the Engineer shall vitiate this contract. In case the Employer / Engineer thinks proper at any time during the progress of the works to make any alterations in, or additions to or omissions from, the works or any alteration in the kind or quality of the materials to be used therein, the Engineer shall give notice thereof in writing to the Contractor or shall confirm in writing within seven days of giving any such oral instructions. The Contractor shall alter, add to, or omit from, as the case may be, in accordance with such notice, but the Contractor shall not do any work extra to or make any alterations or additions to or omissions from the works or any deviation from any of the provisions of the Contract, stipulations, Specification or Contract Drawings without the previous consent in writing of the Engineer and the value of such extras, alterations, additions or omissions shall in all cases be determined by the Engineer in accordance with the provisions of Clause 28 hereof, and the same shall be added to or deducted from the Contract value, as the case may be.

28. Valuation of Variations

No claim for an extra shall be allowed unless it shall have been executed under authority of the Engineer with the concurrence of the Employer as herein mentioned. Any such extra is herein referred to as authorized extra and shall be made in accordance with the following provisions.

28a The net rates or prices in the contract shall determine the valuation of the extra work where such extra work is of similar character and executed under similar conditions as the work priced herein.

28b Rates for all items, wherever possible, should be derived out of the rates given in the Priced Bill of Quantities.

28c The net prices of the original tender shall determine the value of the items omitted, provided if omissions do not vary the conditions under which any remaining items of works are carried out, otherwise the prices for the same shall be valued under sub-clause (c) hereof.

28d Where the extra works are not of similar character and / or executed under similar conditions as aforesaid or where the omissions vary the conditions under which any remaining items or works are carried out, then the contractor shall within 7 days of the date of receipt of order to carry out the work, inform the Engineer of the rate which he intends to charge for such items of work, supported by analysis of the rate or rates claimed and the Engineer shall fix such rate or prices as in the circumstances in his opinion are reasonable and proper, based on the market rate.

28e Where extra work cannot be properly measured or valued, the Contractor shall be allowed day work prices at the net rates stated in the tender of the Priced Bill of Quantities or, if not so stated, then in accordance with the local day work rates and wages for the district; provided that in either case, vouchers specifying the daily time (and if required by the Engineer, the workman's names) and materials employed be delivered for verification to the Engineer at or before the end of the week following that in which the work has been executed.

28f It is further clarified that for all such authorized extra items where rates cannot be derived from tender, the Contractors shall submit rates supported by rate analysis worked on the "market rate basis",

for material, labour, hire / running charges of equipment and wastages etc. plus 15% towards establishment charges, contractor's overheads and profit. Such items shall not be eligible for escalation. The measurement and valuation in respect of the Contract shall be completed within the "Period of Final Measurement" stated in the Appendix or if not stated then within six months of the completion of the Contract works as defined in Clause 39 hereof.

29. Work is to be carried out to the Satisfaction of Architect / Engineer

The Contractor shall carry out all the works strictly in accordance with Drawings, detailed Specifications and instructions of the Architect / Engineer. If in the opinion of the Architect changes have to be made in the works, the Contractor shall carry out the same, and payment, if any, arising out of these shall be made as per the terms of the contract.

30a. Removal of Improper Work & Materials

The Engineer shall, during the progress of the works, have power to order in writing from time to time the removal from the works within such reasonable time or times as may be specified in the order, of any materials which in the opinion of the Engineer are not in accordance with the Specifications or the instructions of the Engineer, the substitution of proper materials, and the removal and proper re-execution of any work executed with materials or workmanship not in accordance with the Drawings and Specifications or instructions, and the Contractor shall forthwith carry out such order at his own cost. In case of default on the part of the Contractor to carry out such order, the Employer shall have the power to employ and pay other persons to carry out the same, and all expenses consequent thereon, or incidental thereto, as certified by the Engineer shall be borne by the Contractor, or may be deducted by the Employer from any moneys due, or that may become due, to the Contractor.

30b. Default of Contractor in Compliance

If the Contractor after receipt of written notice from the Engineer requiring compliance within ten days fails to comply with such further drawings and / or Engineer's / Architect's instructions the Employer may employ and pay other persons to execute any such work whatsoever that may be necessary to give effect thereto, and all costs incurred in connection therewith shall be recoverable from the Contractor by the Employer on the Certificate of the Engineer as a debt or may be deducted by him from any moneys due to the Contractor.

30c. Inspection & Testing During Manufacture

The Engineer shall be entitled during manufacture to inspect, examine and test on the Contractor's premises during working hours the materials and workmanship and check the progress of manufacture of all fabrication materials / items to be supplied under the Contract, and if part of the said materials / items are being manufactured on other premises the Contractor shall obtain for the Engineer permission to inspect, examine and test as if the said Plant were manufacturing on the Contractor's premises. Such inspection, examination or testing if made shall not relieve the Contractor from any obligation under the Contract.

30d. Dates for Inspection & Testing

The Contractor shall agree with the Engineer the date on and the place at which any plant / works will be ready for testing as provided in the Contract and unless the Engineer shall attend at the place so named on the date agreed the Contractor may proceed with the tests, which shall be deemed to have been made in the Engineer's / Architect's presence, and shall forthwith forward to the Engineer duly certified copies of the test readings. The Engineer shall give the Contractor 24 hours notice in writing of his intention to attend the tests. All costs of testing shall be borne by the contractor. All outstation travel expenses shall be borne by the owner but in case re-inspections are required as per clause No. 30 (ix) the travel expenses shall be on contractor's account.

30e. Facilities for Testing at Manufacturer's Works

Where the Contract provides for tests on the premises of the Contractor or of any sub-contractor the Contractor shall provide such assistance, labour, materials, electricity, fuel, stores, apparatus and instruments as may be requisite and as may be reasonably demanded to carry out such tests efficiently.

30f. Certificate of Testing

As and when fabricated materials shall pass the tests referred in this, the Engineer shall furnish to the Contractor a certificate in writing to that effect.

30g. Rejection

If as a result of such inspection, examination or test of the works (other than a Test on Completion under Clause 17.0) the Engineer shall decide that such material is defective or not in accordance with the Contract he shall notify the Contractor accordingly stating in writing his objection and reasons therefore. The Contractor shall with all speed make good the defect or ensures that the material complies with the Contract. Thereafter, if required by the Engineer, the tests shall be repeated under the same terms and conditions save that all reasonable expenses to which the Employer may be put by the repetition of the tests shall be deducted from the Contract Sum.

30h Delivery of Materials & Equipment

Unless the Engineer shall otherwise direct, no material shall be delivered to site until the Engineer shall have issued, in respect of such material, a certificate under Clause 30 (vi) (Certificate of Testing). Likewise Fabricated Materials or Contractor's Equipment shall be delivered to Site only upon an authorization in writing applied for and obtained by the Contractor from the Engineer.

The Contractor shall be responsible for the reception on site of all Materials and Contractor's Equipment delivered for the purposes of the Contract.

30i Inspection & Testing and Re-inspection & Retesting

All deficiencies revealed by testing and inspection shall be rectified by the Contractor at his own expense and to the satisfaction and approval of the Engineer. Rectified components shall be subject to retesting and re-inspection.

30j Inspection Reports

The Contractor shall provide the Engineer with five copies of reports of all inspections and tests.

31. Virtual Completion Certificate

The Engineer shall issue the virtual completion certificate when in his opinion, the works have been substantially completed in all respects and necessary approvals are obtained by the Contractor. The Defects Liability Period shall commence from the date of virtual completion as certified by the Engineer.

32. Defect Liability Period

Any defect or other faults which may appear within the "Defects Liability Period" stated in the Appendix hereto or, if none stated, then within 365 days after the date of the virtual completion of the works as certified by the Engineer, arising in the opinion of the Engineer from materials or workmanship not in accordance with the contract, shall upon the direction in writing of the Engineer, and within such reasonable time as shall be specified therein, be amended and made good by the Contractor, at his own cost and in case of default the Employer may employ and pay other persons to amend and make good such defects or other faults, and all damages, loss and expenses consequent thereon or incidental thereto shall be made good and borne by the

Contractor and such damage, loss and expenses shall be recoverable from him by the Employer or may be deducted by the Employer, upon the Engineer's / Architect's Certificate in writing, from any money due or that may become due to the Contractor, or the Employer may in lieu of such amending and making good by the Contractor deduct from any monies due to the Contractor, a sum, to be determined by the Engineer equivalent to the cost of amending such work and in the event of the amount retained under Clause 46 hereof being insufficient, recover the balance from the Contractor, together with any expenses the Employer may have incurred in connection therewith. Should any defective work have been done or material supplied by any Sub-Contractor employed on the works who has been nominated or approved by the Engineer, the Contractor shall be liable to make good in the same manner as if such work or material had been done or supplied by the Contractor and been subject to the provisions of this Clause and Clause 29 hereof. The Contractor shall remain liable under the provisions of this Clause notwithstanding the signing of any certificate or the passing of any accounts, by the Engineer. The Contractor will not be responsible for defects arising out of fair wear & tear & damage caused by Employer's personnel during the use of the building after being occupied.

33. Approval Only by No Dues Certificate

33a Final Completion Certificate

On successful completion of entire works covered by the Contract to the full satisfaction of Employer / Engineer, the Contractor shall ensure that the following works have been completed to the satisfaction of Engineer : (a) clear the site of all scaffolding, wiring, pipes, surplus materials, Contractor's labour, equipment and machinery (b) demolish, dismantle and remove all Contractor's site offices and other temporary works, structures and constructions and other items and things whatsoever brought upon or

erected at the site or any land allotted to the Contractor by the Owner and not incorporated in the permanent works (c) remove all rubbish, debris etc. from the site and the land allotted to Contractor and shall clear, level and dress, compact the site as required and said land to the satisfaction of the Engineer (d) shall put the Owner in undisputed custody and possession of the site and all land allotted by the Owner to the Contractor (e) All defects / imperfections have been attended & rectified to full satisfaction of the Engineer during the Defect Liability Period. Unless the Contractor shall have fulfilled the provisions of the clause, the works shall not be deemed to have been completed.

Upon the satisfactory fulfillment by Contractor as stated above, the Contractor shall be entitled to apply to the Engineer for a Final Completion Certificate in respect of the entire work.

If the Engineer is satisfied of the completion of the work relative to which the Completion Certificate has been sought, the Engineer shall within 14 (fourteen) days of the receipt of the application for Completion Certificate, issue a Completion Certificate in respect of the works for which the Completion Certificate has been applied.

This issuance of a Completion Certificate shall be without prejudice to the Employer's rights and Contractor's liabilities under the Contract, including the Contractor's liability for the Defect Liability Period nor shall the issuance of a Completion Certificate in respect of the works or work at any site be construed as a waiver of any right or claim of the Employer against the Contractor in respect of work or the works at the site and in respect of which the Final Completion Certificate has been issued.

33b **No Dues Certificate**

The Contract shall remain valid and shall remain incomplete until no dues Certificate shall have been signed by the Engineer and delivered to the Employer with a copy to the contractor. Such a certificate shall be given by the engineer within 30 days of completion of defects liability period (the last period to be considered if different periods to be considered if different parts of the work) or within 30 days from the date of payment of final bill whichever is later.

34a **Prime Cost Items**

The material(s) required for execution of any item for which a sum has been provided as a prime cost price in the tender, shall be procured by the contractor on Employer's instruction from an agency nominated by the Employer. Every sum in the bill of quantities, which contains either as a whole or part the amount as prime cost price of the materials shall be varied by substitution of the actual cost of the materials.

No variation shall be made in respect to the percentage quoted for labour and to cover for overheads & profits on account of variation in the prices, as above.

34b **Provisional Sums**

Every provisional sum other than Prime Cost items under sub-clause (i) of this clause set out in the Bill of Quantities whether for work to be executed by the Contractor which has not been specified in detail when the Contract is entered into or for work to be executed by a nominated Sub-Contractor as hereinafter defined together with the charges and profits, if any, which the Contractor shall have added to such sums shall be deducted from the Contract Value and in lieu thereof shall be added to the Contract Value.

34ba Where work to which the provisional sum relates has been ordered by the Engineer and executed by the Contractor the value of the work so executed valued in accordance with Clause 37c hereof and,

34bb Various items together with lump sum amounts for each of them have been indicated under a separate heading of Provisional Sums, in the B.O.Q. These items are such for which details have not been finalized when the contract is entered into. These items will be got executed either through the Contractor or through a nominated Sub-Contractor, entirely at the discretion of the Employer and shall be paid on the basis of actual cost of each item plus a percentage rate to be quoted by the Contractor to cover his efforts towards co-ordination / assistance including his overheads and profits. No claim shall be entertained if any or all items under the heading of provisional sums are deleted by the Employer from the scope of work to be executed by the Contractor. No further escalation shall be payable on these items. The amounts for these items shall not be considered for variation in contract value as per Clause 24 of GCC.

34bc **Use of Provisional Items**

All sums set out in the Bill of Quantities, which shall be stated to be Provisional shall be used only at the direction & sole discretion of the Employer / Engineer and if not used either wholly or in part, unused amount shall be deducted from the Contract Value. The provisional sum as well as payments made to contractor for assistance / co-ordination / carrying out of works therein shall not be considered for deciding variation in contract value as per Clause 24 of GCC.

34c Production of Vouchers, Etc.

The Contractor shall when required by the Employer / Engineer produce all quotations, invoices, vouchers and accounts or receipts in connection with expenditure in respect of Provisional sums or Prime Cost items.

34d Nominated Sub-contractors / Objection to Nomination

All Specialists, Merchants, Tradesman and others executing any work of supplying and fixing any goods for which prime cost items or provisional sums are included in the Bill of Quantities and / or Specification who may be nominated or selected by the Employer / Architect are hereby declared to be Sub-Contractors employed by the Contractor and are herein referred to as nominated Sub-Contractors.

34da No nominated Sub-Contractor shall be employed on or in connection with the works against whom the Contractor shall make reasonable objection or (save where the Engineer and Contractor shall otherwise agree) who will not enter into a contract providing:

34db That the nominated Sub-Contractor shall indemnify the Contractor against the same obligations in respect of the Sub-Contract as the Contractor is under in respect of this contract.

34dc That the nominated Sub-Contractor shall indemnify the Contractor against claims in respect of any negligence by the Sub-Contractor, his servants or agents or any misuse by him or them of any scaffolding or other plant, the property of the Contractor or under any Workmen's Compensation Act in force.

34e Payment shall be made to the nominated Sub-Contractor within fourteen days of his receipt of payment from the Employer provided that before any Certificate is issued, the Contractor shall upon request furnish to the Engineer proof that all nominated Sub-Contractor's accounts included in previous certificates have been duly discharged, in default whereof the Employer may pay the same upon a Certificate of the Engineer and deduct the amount thereof from any sums due to the Contractor. The exercise of this power shall not create privity of contract as between Employer and Sub-Contractor.

35. Work by Other Agencies

The Employer / Engineer reserves the right to use premises and any portions of the site for the execution of any work not included in this contract which it may desire to have carried out by other persons simultaneously, and the Contractor shall allow all reasonable facilities for the execution of such work and carry out his work in coordination / cooperation with other agencies, but shall not be required to provide any plant or material for the execution of such work except by special arrangement with the Employer. Such work shall be carried out in such manner as not to impede the progress of the works included in the Contract and the Contractor shall not be responsible for any damage or delay which may happen to or occasioned by such work

36. Insurance Policies

The Contractor shall be responsible for all injury or damage to persons, animals or things and for all damage to property which may arise from any factor / omission on the part of the Contractor or any Sub-Contractor or any nominated Sub-Contractor or any of their employees. The liability under this clause shall cover also, inter-alia any damage to structures, whether immediately adjacent to the works or otherwise, any damage to roads, streets, footpaths, bridges as well as damage caused to the building and other structures and works forming the subject matter of this contract. The Contractor shall also be responsible for any damage caused to the buildings and other structures and works forming the subject matter of this contract due to rain, wind, fire, flood or high tide or other inclemency of weather. The Contractor shall indemnify and keep indemnified the Employer and hold him harmless in respect of all and any loss and expenses arising from any such injury or damage to persons or property as aforesaid and also against any claim made in respect of injury or damage, whether under any statute or otherwise and also in respect of any award or compensation or damage consequent upon such claims.

The Contractor shall, at his own expense, effect and maintain till issue of the virtual completion certificate under this contract, with an insurance company approved by the Employer, an All Risks Policy (CAR Policy) for Insurance for an amount equal to 125% of Contract value including earthquake risk in the joint names of the employer and the contractor (the name of the former being placed first in the policy) against all risk as per the standard all risk policy for Contractors and deposit such policy or policies with the employer before commencing the works.

The Contractor shall reinstate all damage of every sort mentioned in this clause so as to do delivery of the whole of the works complete and perfect in every respect and so as to make good or otherwise satisfy all claims for damage to property or third parties.

The Contractor shall also indemnify and keep indemnified the Employer against all claims which may be made against the Employer by any person in respect of anything which may arise in respect of the works or in consequence thereof and shall at his own expense, effect and maintain until the virtual completion of the contract, with an Insurance Company approved by the employer a third party insurance policy in the joint names of the Employer and the contractor (name of the former being placed first in the policy) against such risks and deposit such policy or policies before commencement of the works. The minimum limit of the coverage under the policy shall be Rs.5 lacs per person for any one accident or occurrence and Rs.20 lacs in respect of damage to property for any one accident or occurrence. The Contractor shall also indemnify the employer against all claims which may be made upon the Employer, whether under the Workmen's Compensation Act or any other statute in force, during the currency of this contract or at Common Law in respect of any employee of the Contractor or of sub-contractor and shall be at his own expense effect and maintain until the virtual completion of the contract, with an Insurance Company, approved by the Employer, a policy of Insurance against such risks and deposit such policy or policies with the Employer from time to time during the currency of this contract.

In default of the contractor insuring as provided above, the employer may so insure and may deduct the premiums paid from any money due or which may become due to the contractor.

The contractor shall be responsible for any liability which may not be covered by the Insurance Policies referred to above and also for all other damages to any person, animal or defective carrying out of this contract, whatever, may be the reasons due to which the damage shall have been caused.

The contractor shall also indemnify and keep indemnified the Employer against all and any costs, charges or expenses arising out of any claim or proceedings relating to the works and also in respect of any award of damage or compensation arising there from.

Without prejudice to the other rights of the employer against contractors in respect of such default, the employer shall be entitled to deduct from any sums payable to the contractor the amount of any damages, compensation costs, charges & other expenses paid by the employer and which are payable by the contractor under this clause.

The Contractor shall upon settlement by the Insurer of any claim made against the insurer pursuant to a policy taken under this clause, proceed with due diligence to rebuild or repair the works destroyed or damaged. In this event all the monies received from the Insurer in respect of such damage shall be paid to the Contractor and the Contractor shall not be entitled to any further payment in respect of the expenditure incurred for rebuilding or repairing of the materials or goods destroyed or damaged.

The Contractor, in case of re-building or reinstatement after damage shall be entitled to such extension of time for completion as the Engineer may deem fit, but shall, however, not be entitled to reimbursement by the employer of any shortfall or deficiency in the amount finally paid by the insurer in settlement of any claim arising as set out herein.

Without prejudice to his liability under this clause, the contractor shall also cause all nominated sub-contractors to effect, for their respective portions of the works, similar policies of insurance in accordance with the provisions of this clause and shall produce or cause to produce to the employer such policies. The contractor shall not permit a nominated sub-contractor to commence work at the site unless the said insurance policies are submitted. In the event of failure of the sub-contractor to take out such a policy of insurance before commencing the works at the site, the contractor shall be responsible for any claim or damage attributable to the said sub-contractor.

37. Commencement of Works

-07- days from the date of work order or the date of instruction for taking possession of site, whichever

is later, the contractor shall begin the works and shall regularly proceed with and complete the same on or before the "Date of Completion" stated in the Appendix subject nevertheless to the provisions for extension of time hereinafter contained.

38a. Possession of Site

Save in so far as the Contract may prescribe the extent of portions of the Site of which the Contractor is to be given possession from time to time and the order in which such portions shall be made available to him and subject to any requirement in the Contract as to the order in which the Works shall be executed, the Employer will within 7 day from the Engineer's / Architect's written order to commence the Works give to the Contractor possession of so much of the Site as may be required to enable the Contractor to commence and proceed with the programme referred to in Clause 50 hereof (if any) and otherwise in accordance with such reasonable proposals of the Contractor as he shall, by notice in writing to the Engineer, make & will from time to time as the Works proceed give to the Contractor possession of such further portions of the Site as may be required to enable the Contractor to proceed with the construction of the Works with due dispatch in accordance with the said programme or proposals (as the case may be).

If the Contractor suffers delay or incurs expense from failure on the part of the Employer to give possession in accordance with the terms of this clause the Engineer shall grant an extension of time for the completion of the works without any compensation for delay.

38b Way leaves, etc.

The Contractor shall bear all expenses and charges for special or temporary way leaves required by him in connection with access to the Site. The Contractor shall also provide at his own cost any additional accommodation outside the Site required by him for the purpose of the Works.

39. Time for Completion

The entire work is to be completed in all respects within the time stated in Appendix to "Form of Tender" or such extended time as may be allowed under clause 40 hereof. Time is the essence of the contract and shall be strictly observed by the contractor.

If required in the contract or as directed by the Engineer, the contractor shall complete certain portion of the work before the completion of the whole of the work. However the completion date for whole of the work shall not change.

40. Extension of Time for Completion

If in the opinion of the Engineer the works be delayed for reasons beyond the control of the contractor, the Engineer may make a fair and reasonable extension of time for completion of the contract works.

If the Contractor needs an extension of time for the completion of the work or if the completion of work is likely to be delayed for any reasons beyond the due date of completion stipulated in the contract, the Contractor shall apply to the Employer for extension of time in writing at least 10 days before the expiry of the scheduled time and while applying for extension of time, Contractor shall furnish the reasons in detail and his justification, if any, for the delays. While granting extension, the Engineer shall notify the contractor the period of time which will not qualify for levy of liquidated damages.

For the balance period in excess of original stipulated period and authorized extension of time granted i.e. period not qualifying for levy of liquidated damages, by the Employer, the provision of liquidated damages as stated under Clause 43 will become applicable.

Further, the contract shall remain in force even for the period beyond the due date of completion irrespective whether the extension is granted or not.

41a Rate of Progress

The whole of the materials, plant and labour to be provided by the Contractor and the mode, manner and speed of execution and maintenance of the Works are to be of a kind and conducted in a manner to the satisfaction of the Engineer. Should the rate of progress of the Works or any part thereof be at any time be in the opinion of the Engineer too slow to ensure the completion of the whole of the Works by the prescribed time or extended time for completion, the Engineer shall so notify the Contractor in writing and the Contractor shall thereupon take such steps as considered necessary by the Engineer to expedite progress so as to complete the Works by the prescribed time or extended time for completion. Such communications from the Engineer neither shall relieve the contractor from fulfilling obligations under the contract nor he will be entitled to raise claims arising out of such directions.

41b Work during Night or on Holidays

Subject to any provision to the contrary contained in the Contract none of the permanent work shall save as herein provided be carried on during the night or on Holidays without the permission in writing of the Engineer, save when the work is unavoidable or absolutely necessary for the saving of life or property or for the safety of the Works in which case the Contractor shall immediately advise the Engineer. Provided always that the provisions of this clause shall not be applicable in the case of any work, which becomes essential to carry out by rotary or double shifts in order to achieve the progress & quality of the part of the works being technically required / continued with the prior approval of the Engineer.

All work at night shall be carried out without unreasonable noise & disturbance and with the approval of the Engineer & in addition that of the local authority, if so applicable. The Contractor shall indemnify the Employer from and against any liability for damages on account of noise or other disturbance created while or in carrying out the work and from and against all claims, demands, proceedings, costs, charges & expenses whatsoever in regard or in relation to such liability.

42. Suspension of Work

The Contractor shall on the written order of the Engineer suspend the progress of the Works or any part thereof for such time or times and in such manner as the Engineer may consider necessary and shall during such suspension properly protect and secure the work so far as is necessary in the opinion of the Engineer. The extra cost including all running wages to be paid on the Site, salaries, depreciation and maintenance of plant, Site on costs and overhead costs of the Contract relating to the works done or incurred by the Contractor in giving effect to the Engineer's / Architect's instructions under this Clause shall, be borne and paid by the Employer unless such suspension is :

42a otherwise provided for in the Contract

OR

42b necessary by reason of inclement weather conditions affecting adversely the safety or quality of the Works.

OR

42c necessary by reason of some default on the part of the contractor

Provided that the Contractor shall not be entitled to recover any such extra cost unless he gives notice in writing of his intention to claim to the Engineer within 28 days of the Engineer's / Architect's order. The Engineer shall settle and determine such extra payment and / or extension of time under relevant Clause hereof to be made to the Contractor in respect of such claim as shall in the opinion of the Engineer be fair and reasonable and the Engineer's / Architect's decision shall be final and binding.

43. Liquidated Damages for Delay

If the Contractor fails to complete the works by the period stated in the Appendix or within any extended time under Clause 40 hereof and the Engineer certifies in writing that in his opinion the same ought to have been reasonably completed by the original completion date or extended completion date, as the case may be, the Contractor shall pay the Employer the sum named in the Appendix as "Liquidated Damages" for the period during which the said works shall so remain incomplete or the Employer may deduct such damages from any monies due to the Contractor.

44a. Default of Contractor

If the Contractor being an individual or a firm commits any "act of insolvency", or shall be adjudged an insolvent or being an Incorporated Company shall have an order for compulsory winding up made against it as pass an effective resolution for winding up voluntarily or subject to the supervision of the Court and the Official Assignee or the Liquidator in such acts of insolvency or winding up, as the case may be, shall be unable within seven days after notice to him requiring him to do so, to show to the reasonable satisfaction of the Engineer that he is able to carry out and fulfill the Contract and to give security therefore, if so required by the Engineer.

OR if the Contractor (when an individual, firm or incorporated Company) shall suffer execution or other process of Court attaching property to be issued against the Contractor.

OR shall suffer any payment under this Contract to be attached by or on behalf of any of the creditors of the Contractor.

OR shall assign or sublet this Contract without the consent in writing of the Employer.

OR shall charge or encumber this Contract or any payments due or which may become due to the Contractor hereunder.

OR if the Engineer shall certify in writing to the Employer that the Contractor.

44b Has abandoned the Contract, or

44c Has failed to commence the works, or has without any lawful excuse under these conditions suspended the progress of the works for fourteen days after receiving from the Engineer's / Architect's notice to proceed with the work

OR

44d Has failed to proceed with the works with such due diligence and failed to make such due progress as would enable the works to be completed within the time agreed upon,

OR

44e Has failed to remove materials from the site or to pull down and replace work for seven days after receiving from the Engineer written notice that the said materials or work were condemned and rejected by the Engineer under these conditions,

OR

44f Has neglected or failed persistently to observe and perform all or any of the acts, matters or things by this contract to be observed & performed by the Contractor for seven days after written notice shall have been given to the Contractor requiring the Contractor to observe or perform the same.

Then and in any of the said cases the Employer may, notwithstanding any previous waiver, after giving seven days notice in writing to the Contractor, determine the Contract, but without thereby affecting the powers of the Engineer or the obligations and liabilities of the Contractor, the whole of which shall continue in force as fully as if the Contract had not been so determined, and as if the works subsequently executed had been executed by or on behalf of the Contractor. And further, the Employer by his agents or servants may enter upon and take possession of the works and all plants, tools, scaffoldings, sheds, machinery, steam and other power utensils and materials lying upon the premises or the adjoining lands or roads and use the same as his own property or may employ the same by means of his own servants and workmen in carrying on and completing the works or by employing any other Contractor shall not in any way interrupt or do any act, matter or thing to prevent or hinder such other Contractor or other person or persons employed for completing and finishing or using the materials and plant for the works. When the works shall be completed or as soon, thereafter, as convenient the Engineer shall give a notice in writing to the Contractor to remove his surplus materials and plant and should the Contractor fail to do so within a period of fourteen days after receipt thereof by him, the Employer may sell the same by public auction, and give credit to the Contractor for the net amount realized. The Engineer shall, thereafter, ascertain and certify in writing under his hand what (if anything) shall be due or payable to or by the Employer, for the value of the said plant and materials so taken possession of by the Employer and the expense or loss which the Employer shall have been put to in procuring the works to be completed and the amount, if any, owing to the Contractor and the amount which shall be so certified shall thereupon be paid by the Employer to the Contractor or by the Contractor to the Employer, as the case may be, & the Certificate of the Engineer shall be final and conclusive between the parties.

44g **Default of Employer**

If the payment of the amount payable by the Employer under Certificate of the Engineer shall be in arrears and unpaid for thirty days after notice in writing requiring payment of the amount as aforesaid shall have been given by the Contractor to the Employer, or if the Employer interferes with or obstructs the issue of any such Certificate, or if the Employer shall repudiate the Contract, or if the works be stopped for three months under the order of the Engineer or the Employer or by any injunction or other order of any Court of Law, then and in any of the said cases, the Contractor shall be at liberty to determine the Contract by notice in writing to the Employer, through the Engineer, and he shall be entitled to recover from the Employer, payment for all works executed at site. All other expenditure to be borne by the Contractor.

In arriving at the amount of such payment the net rates contained in the Contractor's original Tender shall be followed or where the same may not apply valuation shall be made in accordance with Clause 28 hereof.

45a **Determination of Contract**

The Employer shall in addition to any other power enabling him to determine the Contract have power to determine the Contract at any time by giving not less than fourteen (14) days notice in writing to the Contractor and on the expiry of such notice the Contractor shall (with the exception of this clause and clause 44 hereof) forthwith determine but without prejudice to the claims of either party in respect of any antecedent breach thereof.

45b Compliance with Engineer's / Architect's Direction on Determination

If the Contract shall be determined under the provisions of the clause 45 (i) the Contractor shall with all reasonable dispatch comply with the directions of the Engineer in respect to :

45ba Cancellation of outstanding commitments

45bb Performance of further work required for the protection of work executed.

45bc The removal of Constructional Plant Temporary Works and materials from the Site

45bd Any other matters arising out of the Contract with regard to which the Engineer decides that directions are necessary or expedient.

45c Payment on Determination

In the event of the Contract being determined under the provisions of this Clause the sum payable to the Contractor shall be such sum as would have been payable under Clause 47 hereof as if the contract had been determined by the Employer under the provision of Clause 45 hereof and

45ca The reasonable cost of complying with the Engineer's / Architect's directions under sub-clause hereof

45cb Such reasonable sum as may be agreed between the parties or in default of agreement settled by arbitration in respect of the Contractor's overheads including any sums properly and necessarily incurred as the direct result of such determination.

45d The Engineer has a right to ascertain the happening of any contingency, including but not limited to the contingencies listed below, which would vest in the Employer certain powers including, but not limited to, taking possession of the work so far as it has been performed, and to completing the work either by himself or by employing some other Agency, retaining property of the Contractor, such as materials, plant or money already due to the Contractor:

45da Failure of Contractor to proceed with or complete the works in the time or manner stipulated

45db Contractor's bankruptcy

45dc Failure of Contractor to commence the work

45dd Failure of Contractor to regularly proceed with the work for a certain fixed period

45de Failure of Contractor to proceed to the satisfaction of the Employer or the Engineer

45df Failure of Contractor to proceed with the work for any reason independent of prevention by Employer

45dg If in the Engineer's / Architect's opinion, the Contractor is not exercising due diligence and proceeding with such dispatch as will enable the works to be duly completed in time

45dh Failure of Contractor in complying with the orders and directions given by the Engineer

45di Failure of Contractor in complying with the Specification, stipulations, conditions or Drgs.

45dj The Contractor being guilty of any default in the fulfillment of the contract

45dk The Contractor leaves the work unfinished

45dl Failure of Contractor, after due notice, to rectify defective work

45dm The Contractor renouncing materials from site and

45dn Failure of Contractor to maintain the works

46. Security Deposit / Retention Money

In addition to the Initial Security Deposit as further security for the due fulfillment of the contract by the Contractor, 8% of the value of the work done will be deducted by the Employer from each payment to be made to the Contractor towards retention money until the retention money amounts to 5% of the contract value (excluding the cost of Operation & Annual Maintenance Contract) including the initial Security Deposit. On the Engineer's / Architect's issuing a certificate of virtual completion of the works, 50% of the security deposit shall be released to the contractor, and the remaining 50% will be released by the Employer after the Contractor obtains the no dues certificate from the engineer subject to Clause 33. The amounts retained by the Employer shall not bear any interest.

All compensation or other sums of money payable by the Contractor to the Employer under the terms of this contract may be deducted from the security deposit if the amount so permits and the Contractor

shall, unless such deposit has become otherwise payable, within ten days after such deduction make good in cash the amount so deducted.

The security deposit of the contractor will be forfeited if he fails to comply with any of the conditions of the contract.

47. Certificates & Payment

47a Secured Advance on Materials at Site

The Contractor will be paid secured advance against the materials brought and stacked at site for use in permanent works and in the opinion of the Engineer are required to be procured in advance. The advance paid for the materials stacked at site shall be maximum 80% of the cost of the materials or 65% of the relevant item rate, whichever is less at the discretion of Engineer and the Contractor shall produce necessary vouchers / documents in support of cost of each material. No advance shall be admitted for perishable and materials procured prematurely as decided by the Engineer.

Where in any Certificate (of which the Contractor has received payment), the Engineer has included the value of any unfixed materials intended for and / or placed on or adjacent to the works such materials shall become the property of the Employer and they shall not be removed except for use upon the works, without the written authority of the Engineer. The Contractor shall be liable for any loss of, or damage to, such materials.

The materials shall also be in conformity with contract specifications and of approved quality as stated in relevant clauses hereof. These advance shall be made on the basis of the quantity of each material lying at site at the time of preparation of each interim bill. The Contractor shall sign indemnity bond for any loss either due to theft or fire etc.

47b Running Bill Payments

The Contractor shall be paid by the Employer from time to time by installments under Interim Certificate to be issued by the Engineer to the Contractor on account of the works executed when in the opinion of the Engineer, work to the approximate value named in the Appendix to form of tender "Minimum value of Work for Interim Certificate" (or less at the sole discretion of the Engineer) has been executed in accordance with this contract, subject to a retention of the percentage of such value named in the Appendix to form of tender hereto as 'Retention Percentage for Interim Certificates' until the total amount retained shall reach the sum named in the Appendix to form of tender as 'Security Deposit'.

47c The contractor shall be paid two bills in a month, which shall include work done and secured advance against material. If in the opinion of the Engineer the progress of the work warrants a third payment in a month, the same shall be so arranged by the Employer.

47d After submission of bill along with complete information, vouchers etc. to the satisfaction of the Engineer & after making necessary deductions toward Vat, Income Tax, Work Contract Tax & other recoveries deductible at source, the bill will be paid as follows:

47da An ADHOC PAYMENT of 75% of the value of work done as assessed by the Engineer shall be released within 7 working days by the Employer, after certification by the Engineer who will certify within 4 working days of submission of Bill including furnishing of all relevant documents.

47db Balance amount shall be certified by the Engineer within 10 working days of submission of bill and payment shall be released by the Employer within 5 working days of certificate receipt.

47e Final Bill

The Contractor shall submit final bill within **45 days** from the date of issue of virtual completion certificate with all relevant information and details including as-built drawings, operation and maintenance manual, photographs etc. complete. The last date of submission of all relevant documents shall be reckoned as the date of final submission.

47f The Engineer within **45 days** of submission of the final bill, shall issue a certificate of payment against the final bill to the Employer who shall thereupon, within **45 days** from the date of receipt of the certificate, shall release the balance payment to the contractor after effecting all recoveries, including advances & payments against interim certificates.

47g The Engineer shall have power to withhold Certification if the works or any parts thereof are not being carried out to his satisfaction.

47h The Engineer may by any Certificate make any correction in any previous Certificate, which shall have been issued by him.

47i No payment shall be made to the Contractor if the Contractor fails to insure the works & keep

them insured till the issue of the Virtual Completion Certificate.

48. **Settlement of Disputes and Differences**

48a The Contractor shall try to settle all matters pertaining to this contract first with the Engineer. The decision of the Engineer may be in the form of a certificate, instruction or otherwise. The decision, opinion, direction, certificate for payment with respect to all or any of the matters under Clauses 18, 30, 31 and 32 hereof (which matters are hereinafter referred to as excepted matters) of the Engineer shall be final and conclusive and binding on the Contractor and Employer and shall be without appeal.

48b All other disputes and differences of any kind whatsoever between the Contractor and the Engineer arising out of or in connection with the contract or carrying out the works (whether during progress of work or within defects liability period and whether before or within 365 days of determination / abandonment / breach of the contract) shall then be referred by the Contractor to the Employer giving inter-alia full details of matter under dispute and the reasons thereof. The Employer shall within a period of 60 days from the receipt of such reference from the contractor, give his decision in writing. If the Contractor is dissatisfied with the decision of the Employer, he can refer the matter for arbitration by serving a written notice on the Employer, through the Engineer within a period of 28 days of such decision. The notice shall specify the matters with full details and amount, which are in dispute and referred for arbitration.

49. VOID

50. **Programme of Works**

50a **Detailed Programme to be Furnished:**

Within 15 days of receiving letter of Acceptance / Award the Contractor shall prepare and submit a detailed programme of works in the form of a Bar Chart / Mile stone network showing all activities & the order of procedure in which he proposes to carry out the works including labour histogram, cash flow and deployment of equipments. Within 15 days from the date of submission, the Engineer shall convey to the Contractor his comment / approval on the programme.

The contractor shall be required to submit the PERT / CPM chart for the various activities involved in this work including dependencies etc., and regularly monitor the progress of works accordingly.

50b **Programme to be modified**

Subject to the provisions of Clause 39 hereof, if at any time it should appear to the Engineer that the actual progress of the works does not conform to the approved programme referred to in sub-clause (i) of this Clause, the Contractor shall produce a revised & detailed programme showing the modifications to the original programme necessary to ensure the completion of the works within the time for completion as defined in Clause 39 hereof.

(iii) **Cash Flow**

50c The detailed programmes shall also show the estimated Cash flow required for each month to complete the works.

50d **Progress Report**

Four copies of monthly progress reports containing the following shall be submitted by the Contractor to the Employer through the Engineer on or before the 5th day of the next month.

50da Monthly detailed progress report showing the progress of individual activities of programme as achieved at site till such period and being suitably marked on the approved network diagram, or as directed by the Engineer, shall be provided by the Contractor indicating the actual state of progress during the course of the contract, together with other details of procurement & delivery schedules of materials / equipments, as required by the Engineer.

50db Labour report in the form prescribed by the Engineer.

50dc Equipment & machinery report in the form prescribed by the Engineer.

50dd Supervisory staff report in the form prescribed by the Engineer.

50de Remedial Measures for covering up delay, if any,

50df Bottlenecks and hindrances,

50dg Minimum 5 Nos. of colour photographs of 7" x 5" with each report showing the progress of works.

Apart from the above the Contractor shall submit daily report indicating regular deployment of his staff and workers, equipments, important stages of progress, procurement of construction materials etc. as approved by the Engineer.

51. Urgent Repairs

If by reason of any accident or failure or other event occurring to in or in connection with the Works, or any part thereof, either during the execution of the Works or during the Period of Defect Liability / Maintenance any remedial or other work or repair shall, in the opinion of the Engineer or Engineer's / Architect's representative be urgently necessary for security and safety of life or for the works or of adjoining property and the Contractor is unable or unwilling at once to do such work or repair, the Employer may employ his own or other workmen do such work or repair, as the Engineer or the Engineer's / Architect's representative may consider necessary. If the work or repair so done by the Employer which is in the opinion of the Engineer, the Contractor was liable to do at his own expense under the Contract, all costs and charges incurred by the Employer in so doing shall on demand be paid by the Contractor to the Employer or may be deducted by the Employer from any monies due or which may become due to the Contractor. Provided always that the Engineer or the Engineer's / Architect's representative (as the case may be) shall, as soon after the occurrence of any such emergency, as may be reasonably practicable notify, the Contractor thereof in writing.

52. VOID

53. VOID

54. Contractor to Search

The Contractor shall, if required by the Engineer in writing, search, test as shall be necessary to determine the cause of any defect, imperfection or fault under the directions of the Engineer. Unless such defect, imperfection or fault shall be one for which the Contractor is liable under the contract the cost of the work carried out by the Contractor in searching as aforesaid shall be borne by the Employer. But if such defect, imperfection or fault shall be one for which the Contractor is liable as aforesaid, the cost of the work carried out in searching as aforesaid shall be borne by the Contractor and he shall in such case repair rectify and make good such defect, imperfection or fault at his own expense in accordance with the provisions of Clause 30 hereof.

55. Interference with Traffic and Adjoining Properties

All operations necessary for the execution of the Works and for the construction of any Temporary Works shall so far as in compliance with the requirements of the Contract permits be carried on so as not to interfere unnecessarily or improperly with the public convenience or the access to use and occupation of public or private roads and footpaths or to or of properties whether in the possession of the Employer or of any other person and the Contractor shall save harmless and indemnify the Employer in respect of all claims, demands, proceedings, damages, costs, charges and expense whatsoever arising out of or in relation to any such matters in so far as the Contractor is responsible.

56a. Extraordinary Traffic

The Contractor shall use every reasonable means to prevent any of the highways or bridges communicating with or on the routes to the Site from being damaged or injured by any traffic of the Contractor or any of his sub-contractors and in particular shall select routes and use vehicles and restrict and distribute loads so that any such extraordinary traffic as will inevitably arise from the moving of plant and material from and to the site shall be limited as far as reasonably possible and so that no unnecessary damage or injury may be occasioned to such highways and bridges.

56b Special Loads

Should it be found necessary for the Contractor to move one or more loads of Constructional Plant Machinery or pre-constructed units or parts of units of work over part of a highway or bridge the moving whereof is likely to damage any highway or bridge unless special protection or strengthening is carried out then the Contractor shall adopt proper & adequate measures and shall be responsible for all the costs and consequences thereof.

56c Settlement of Extra Ordinary Traffic Claims

If during the carrying out of the works at any time or thereafter the Employer shall receive any claim arising out of the execution by the Contractor of the Works in respect of damage or injury to highways or bridges he shall immediately report the same to the Engineer and the Contractor and thereafter the Contractor shall negotiate the settlement of and pay all sums due in respect of such claims and shall

indemnify the Employer in respect thereof and in respect of all claims, demands, proceedings, damages, costs charges and expenses in relation thereto provided always that if and so far as any such claims or part thereof shall in the opinion of the Engineer be due to any failure on the part of the Contractor to observe and perform his obligations then the amount certified by the Engineer to be due to such failure shall be paid by the Contractor.

57a Contractor to Keep Site Clear

During the progress of the works the Contractor shall keep the site reasonably free from all unnecessary obstruction and shall store or dispose of any constructional plant and surplus materials and clear away and remove from the site any wreckage, rubbish or temporary works which are no longer required.

57b Clearance of Site on Completion

On the completion of the Works the Contractor shall clear away and remove from the site all constructional plant, surplus materials, rubbish and temporary works of every kind and leave the whole of the site and works clean and in a workmanlike condition to the full satisfaction of the

Engineer / local authorities not later than 30 days from the virtual completion of the works or by such other later date as fixed by the Engineer.

58 Construction Plant

58a Definition

For the Purpose of this Clause

58aa The expression "Constructional Plant" shall be deemed to exclude vehicles engaged in transporting any plant, equipment or materials & staff to or from the site.

58ab The expression "Hired Plant" shall mean any Constructional Plant, Temporary Works and materials for Temporary Works held by the Contractor under any agreement for hire thereof.

58ac The expression "Hire Purchase Plant" shall mean any Constructional Plant Temporary Works and materials for Temporary Works held by the Contractor under any agreement for hire purchase thereof.

58b Hire Purchase of Plant Exclusively for Works

All Constructional Plant, Temporary Works and materials owned by the Contractor or by any person, company or firm in which the Contractor has a controlling interest shall when brought on to the Site (or in the case of Hire Purchase Plant on the Site on its becoming the property of the Contractor) shall be deemed to be exclusively intended for execution of the works and shall be deemed to be the property of the Employer till completion of the works.

58c Conditions of Hire of Certain Plant

With a view to securing in the event of a forfeiture under Clause 45 hereof the continued availability for the purpose of executing the Works of any of Hired Plant the Contractor shall not bring on to the Site any Hired Plant unless there is an agreement for the hire thereof which contains a provision that the owner thereof will on request in writing made by the Employer within seven days after the date on which any such forfeiture has become effective and on the Employer undertaking to pay all hire charges in respect thereof from such date, hire such Hired Plant to the Employer on the same terms in all respects as the same was hired to the Contractor save that the Employer shall be entitled to permit the use thereof by any other contractor employed by him for the purpose of completing the works.

58d Cost of Hiring Plants for purposes of Clause 45

In the event of the Employer entering into any agreement for hire of Hired Plant pursuant to the provisions of Sub-Clause (iii) of this Clause all sums properly paid by the Employer under the provisions of any such agreement and all expenses incurred by him (including stamp duties) in entering in to such agreement shall be deemed for the purpose of Clause 45 hereof to be part of the cost of completing the Works.

58e Contractor's Certificate as to Hiring Provisions

The Contractor shall upon request made by the Engineer at any time in relation to any item of Hired Plant forthwith notify to the Engineer in the name and address of the owner thereof and shall certify that the agreement for the hire thereof contains a provision in accordance with the requirements of

sub-clause (iii) of this Clause. The Contractor shall also upon request as aforesaid give a like notification (but without certificate) in regard to any Hire Purchase Plant. The Contractor shall upon the request made by the Engineer provide the Engineer with true copy/copies of such agreement(s).

58f Hire Purchase Payments by Employer

The Employer shall in order to avoid seizure by the owner of any Hire Purchase Plant be entitled to pay to such owner the amount of any overdue installment or other sum payable under any agreement for hire purchase of plant and in the event of his doing so any amount so paid by him shall be debt due from the Contractor to the Employer and shall be deducted by the Employer from any monies due or that may become due to the Contractor under the Contract or otherwise or may be recovered by the Employer from the Contractor as per the law.

58g Plants Etc. Not to be Removed

No Constructional Plant, Temporary Works or materials or any part thereof shall be removed from the site without the written consent of the Engineer, which consent shall not be unreasonably withheld where the same is no longer immediately required for the purpose of completion of the Works. The Employer will permit the Contractor the exclusive use of all such Constructional Plant, Temporary Works and materials in and for the completion of the Works until the happening of any event, which gives right to the Employer to exclude the Contractor from the Site and proceed with the completion of the Works.

58h Re-vesting & Removal of Plant

Upon removal of any such Constructional plant Temporary Works or materials as have been deemed to have become the property of the Employer under sub-clause (ii) of this Clause with consent of the Employer the property therein shall be deemed to re-vest in the Contractor and upon completion of the Works the property in the remainder of such Constructional Plant, Temporary Works and Materials as aforesaid shall subject to the provisions of Clause 45 hereof be deemed to re-vest in the Contractor who shall remove the same together with Hire Purchase Plant.

58i Disposal of Plant

If the Contractor shall fail to remove any Constructional plant Temporary works or materials as aforesaid or any Hired plant, or Hire Purchase Plant within such reasonable time after completion of the Works as may be allowed by the Engineer at its discretion then the Employer may sell any such Constructional Plant, Temporary works and materials as aforesaid and return at the Contractor's expense to the person or company from whom any hired Plant or any Hired Purchases Plant was hired by the Contractor; and after deducting from any proceeds of sale the costs, charges and expenses of and in connection with such sale and of and in connection with return as aforesaid shall pay the balance (if any) to the Contractor but to the extent that the proceeds of any sale are insufficient to meet all such costs, charges and expenses the excess shall be a debt due from the Contractor to Employer & shall be a deductible or recoverable by from any items that may be due from any monies to the Contractor.

58j Liability for Loss or Injury to Plant

The Employer shall not at any time be liable for the damage / loss of or injury to any of the Constructional Plant Temporary works or materials which have been deemed to become the property of the Employer under sub-clause of this Clause, save as mentioned in above Clause.

58k Incorporation of Clause in Sub-Contracts

The Contractor shall when entering into any sub- contract for the execution of any part of work incorporate in such sub-contract by reference or otherwise the provisions of this Clause in relation to Constructional Plant, Temporary Works and Materials, Essential Hired Plant and Hire Purchase Plant brought on to the site by the Sub-Contractor.

59a Labour Laws

The Contractor shall observe and strictly adhere to all prevailing labour laws inclusive of Contract Labour (Regulation and Abolition) act of 1970 (latest revision) and other safety regulations.

59b Supply of Water

The Contractor shall having regard to local conditions provide on the Site to the satisfaction of the Engineer an adequate supply of drinking and other water for the use of the Contractor's staff, workmen, Engineer's / Architect's staff for the work.

59c Festivals & Religious Customs

The Contractor and sub-contractor's agents and employees shall in all their dealings with their workmen and labourers for the time being employed on or in connection with the works have due regard to all recognized festivals and religious and other customs.

59d Epidemics

In the event of any outbreak of illness of an epidemic nature the Contractor shall comply with and carry out such regulations, orders and requirements as may be made by the Government or the local medical or sanitary authorities for the purpose of overcoming the same.

59e Disorderly Conduct

The Contractor shall at all times take all reasonable precautions to prevent any unlawful, riotous or disorderly conduct by or amongst his or his sub- contractor's employees and for the preservation of peace and protection of persons and property in the neighborhood of the works against the same but the contractor shall not interfere with member of any authorized Police Force who shall have free & undisputed access at all times to any part of the Works in the execution of their duties.

59f Accidents

The Contractor shall immediately on occurrence of any accident at or about the Site or in connection with the execution of the work report such accident to the Engineer's / Architect's representative. The Contractor shall also report such accident immediately to the competent authority whenever such report is required to be lodged by law & take appropriate actions thereof. The Contractor shall submit to the Engineer safety statistics as per the format given in "Annexure F".

59g Fair Wages

The Contractor shall in respect of all persons employed by him in factories, workshops or other places occupied or used by him for the execution of the Contract including the Works, pay rates or wages, emoluments and expenses and observe hours and conditions of labour not less favorable than those established for the trade or industry in the district where the work is carried out to which the organizations of employers and trade unions representatives or a substantial proportions of the employers and workers engaged in the trade or industry in the district are affiliated. In the absence of such established rates and conditions the Contractor shall pay rates or wages and observe hours and conditions of labour which are not less favorable than the general level of wages, hours and conditions observed in the trades or industries similar to those in which the Contractor is engaged.

The Contractor shall comply with the provision of all labour legislation including the latest requirements of all the Acts, Laws, any Regulation or Bylaws or any local or other statutory Authority applicable in relation to the execution of works, such as:

59ga Minimum wages Act, 1948 (Amended)

59gb Payment of Wages Act, 1936 (Amended)

59gc Workmen's Compensation Act, 1923 (Amended Act No 65 of 1976)

59gd Contract Labour Regulation & Abolition Act, 1970 and Central Rules 1971 (Amended)

59ge Apprentices Act 1961

59gf Any other Act or enactment relating thereto and rules framed thereunder from time to time

59gg Industrial Employment (standing order) Act, 1946 (Amended)

59gh Personal Injuries (Compensation Insurance) Act, 1963 and any modifications thereof & rule made thereunder from time to time.

59gi Employees' Provident Fund & Miscellaneous Provisions Act, 1952 and amendment thereof.

59ha Workmen's Compensation

If, for any reason, the Employer is obliged, by virtue of the provisions of the Workmen's Compensation Act, 1923, or any statutory modification or reenactment thereof to pay compensation to a workman employed by the Contractor in execution of the works, the Employer shall be entitled to recover from the Contractor the amount of compensation so paid and without prejudice to the rights of the Employer under the said Act. The Employer shall be at liberty to recover such amount or any part thereof by deducting it from the security deposit or from any sum due by the Employer to the Contractor under this Contract or otherwise. The Employer shall not be bound to contest any claim made against it under the said Act, except on the written request of the contractor and upon his giving to the Employer full security to the satisfaction of the Employer for all costs for which the Employer might become liable in consequence of contesting such claim.

59hb Observance by Sub-Contractors



The Contractor shall be responsible for the observance by sub-contractors employed by him in the execution of this Contract of the provisions hereof and applicable laws, rules and regulations.

59hc Contractor will have to obtain Contractors All Risk insurance policy with an amount equal to 110% of the value of the contract on "all risk basis" including strikes, riots and civil commotion etc. for third party compensation (for Minimum Amount of Third Party Insurance) as workman compensation policy so as to cover the risks detailed in above clause and that the listed policies normally cover. Policies will have to be taken out jointly in name of BOB and the contractor with BOB named first, Original policies will have to be submitted to BOB.

60. **Safety Code**

61a First aid appliances including adequate supply of sterilized dressings and cotton wool shall be kept in a readily accessible place.

61b An injured person shall be taken to a public hospital without loss of time, in cases where the injury necessitates hospitalization.

61c Suitable and strong scaffolds should be provided for workmen for all works that cannot safely be done from ground.

61d No portable single ladder shall be over 8 meters in length. The width between the side rails shall not be less than 30 cm. (clear) and the distance between two adjacent rungs shall not be more than 30 cm. When a ladder is used an extra mazdoor shall be engaged for holding the ladder.

61e The excavated material shall not be placed within 1.5 meters of the edge of the trench or half of the depth of trench whichever is more. All trenches and excavations shall be provided with necessary fencing and lighting.

61f Every opening in the floor of a building or in a working platform be provided with suitable means to prevent the fall of persons or materials by providing suitable fencing / railing of minimum height of one meter.

61g All staff and workers employed in the work shall be provided with safety shoes, helmet, belt, etc.

61h No floor, roof or other part of the structure shall be so overloaded with debris or materials as to render it unsafe.

61i Those engaged in welding works shall be provided with welder's protective eye-shields and gloves.

61ja No paint containing lead or lead products shall be used except in the form of paste or readymade paint.

61jb Suitable facemasks should be supplied for use by the workers when the paint is applied in the form of spray or surface having lead paint dry rubbed and scrapped.

61k Overalls shall be supplied by the Contractor to the painters and adequate facilities shall be provided to enable the working painters to wash during the periods of cessation of work.

61l Hoisting machines and tackle used in the works, including their attachments, anchorage and supports shall be in perfect condition.

61m The ropes used in hoisting or lowering materials or as a means of suspension shall be of durable quality and adequate strength and free from defects.

61n Contractor shall appoint "Safety Officer" to maintain safety records to the satisfaction of the Engineer.

CONDITIONS OF FORCE MAJEURE

The terms "Force Majeure" as employed herein shall mean act of God, war, revolt, riot, fire, flood and Acts & Regulations of respective Governments of the two parties namely the Employer and the Contractor.

Note: - "Typhoon" is covered under act of God"

In the event of either party being rendered unable by force majeure to perform any of obligation required to be performed by them under the Contract, the relative obligation of the party affected by such Force Majeure shall upon notification to the other party be suspended for the period of delay which is directly caused by such Force Majeure event.

Upon the occurrence of such cause and upon its termination, the party alleging that it has been rendered unable as aforesaid thereby, shall notify the other party in writing within (72) seventy two

hours of the alleged beginning and ending thereof giving full particulars and satisfactory evidence in support of its claim.

Time for performance of the relative obligation suspended by the Force Majeure shall then stand extended by the period of delay, which is directly caused by Force Majeure event. The party who has given such notice shall be excused from timely performance of its obligations under the Contract, for so long as the relevant event of Force Majeure continues and to the extent that such parties performance is prevented, hindered or delayed, provided the party or parties affected by the event of Force Majeure shall use reasonable efforts to mitigate the effect thereof upon its performance of the Contract and so to fulfill its obligations under the Contract.

If works to be executed by the Contractor are suspended by Force Majeure conditions lasting for more than (2) two months, the Employer shall have the option of canceling or terminating this Contract in whole or part thereof at Employer's discretion. Upon such termination provisions of Clause 45 shall apply.

Delay or non-performance by a party hereto caused by the occurrence of any of Force Majeure shall not:

- a) Constitute a default or breach of the Contract,
- b) Give rise to any claim for damages or additional cost or expense occasioned thereby : if such delay or non-performance is caused by the occurrence of any event of Force Majeure. Force Majeure conditions shall not be payable under any circumstances.

SPECIAL CONDITIONS OF CONTRACT

01 Scope of Work

The scope of the work is to carry out **Proposed Civil, Interior/Furnishing, Electric, Air-conditioning Works at Bank of Baroda, Upleta Branch, Upleta.**

The Interior works broadly comprise of:

- a) Paneling and Partition Works
- b) False Ceiling works.
- c) Painting and Varnishing works.
- d) Supply and installation of Tables, partitions, Sofas and storage units.
- e) Supply and installation of window dressings.
- f) Miscellaneous Works

02 Location of Site

The site is located at **Upleta.**

03 Area for the Contractor

The area to the extent available, at the discretion of the Architect/Engineer, from the said plot will be allocated to the contractor for his stores, offices, erection of plants, workshops etc. Any additional area including area for labour camp etc. shall be arranged by the contractor at his own cost. The Employer neither undertakes any responsibility for providing the area more than the above nor will entertain any claim/ reimbursement etc. towards arrangement of additional area / land etc. by the contractor.

04 Dimensions and Levels

All dimensions and levels shown on the Drawings shall be verified by the Contractor on the Site and he will be held responsible for the accuracy and maintenance of all the dimensions and the levels.

Figured dimensions are in all cases to be accepted and no dimension shall be scaled. Large-scale details shall take precedence over small-scale drawings. In case of discrepancy the Contractor shall ask for clarification from the Engineer before proceeding with the work.

05 Notice of Operation

The Contractor shall not carry out any important operation without the consent in writing of the Engineer.

06 Construction Records

The Contractor shall keep and provide to the Engineer full and accurate records of the dimensions and positions of all new work and any other information necessary for the Engineer.

07 VOID

08 Temporary Works

Before any Temporary Works are commenced the Contractor shall submit at least 7 days in advance to the Engineer for approval, complete drawings of all Temporary Works he may require for the execution of the works. The Contractor shall also submit his calculations relating to strength, if required by the Engineer and shall carry out the modifications that the Engineer may require in accordance with the Conditions of Contract at his own cost. The Contractor shall be solely responsible for the stability and safety of all Temporary Works and unfinished works and for the quality of the permanent works resulting from the arrangement eventually adopted for their execution.

09 VOID

10 Power, Water & Other Facilities

10a The Contractor shall make his own arrangements for the supply of good quality potable water at site, for his labour at site, and all charges for water shall be borne by him. If Municipal water is not available and should it become necessary for Contractor to bore wells for obtaining water for construction purposes or to bring water from outside by tankers, the Employer shall not be liable to pay any charges in connection therewith.

10b The rate quoted in the tender shall also include electric consumption charges for power.

10c For water and electricity, the Contractors shall be entitled to take connections from the temporary water and electric supply connection either by electric supply or diesel generation power obtained by the General Building Contractor, at his cost. The Contractor shall install a sub-meter separately for electricity and water supply at the location adjacent to the main meter for measuring

electric / water consumption at their own cost and maintain the wiring / installation in good condition as per the local rules and reimburse the actual consumption charges directly to the General Building Contractor at mutually agreed rates between them. In case of any dispute, the reimbursement charges shall be decided by the Engineer, whose decision shall be final and without appeal.

10d The Contractor is to provide at site at his cost at least one telephone cum fax machine and shall allow the client, consultant and Engineer's / Architect's representative for use of the same at free of cost for local use.

11 Temporary Services

The Contractor shall provide and maintain all temporary services on or about the site, if any required for the execution of the works and shall remove them on completion.

12 Office Accommodation for Contractor

The Contractor shall provide and maintain all necessary office(s), workshops, stores, shelters, sanitary facilities, canteens and other temporary buildings for themselves and their staff at site to the approval of the Engineer.

All temporary buildings of Contractor shall be removed at the completion of the project or at any earlier date as directed by the Engineer without any extra cost.

All the expenses for obtaining statutory approvals and maintenance of the above facilities as well as running expenses shall be borne by the contractor at no extra cost. It is also responsibility of the Contractor to obtain statutory approvals for providing above facilities.

13 VOID

14 Facilities for Contractor's Employees

The Contractor shall make his own arrangement for the housing and welfare of his staff and workmen including adequate drinking water and sanitary facilities. The Contractor shall also make his own arrangements at his own cost for transport where necessary for his staff and workmen to and from the Sites of the works. The necessary drinking water and sanitary facilities for Employer's & Engineer's / Architect's representative, contractor's staff & labour & visitors at site shall be provided and maintained by the contractor at no extra cost.

15 Lighting for Works

The Contractor shall at all times provide adequate and approved lighting as required for the proper execution and supervision & inspection of the works.

16 Fire Fighting Arrangement

16a The Contractor shall provide suitable arrangements for firefighting at his own cost. For this purpose, he shall provide requisite number of Fire-Extinguishers and adequate number of buckets, some of which are to be always kept filled with sand and some with water. These equipment shall be provided at suitable prominent and easily accessible places and shall be properly maintained.

16b The Contractor may be subject to periodic fire prevention inspections and any deficiency or unsafe condition shall be corrected by the Contractor at his own cost and to approval of the Engineer and the relevant authorities.

These fire prevention inspections shall include but not limited to the following:

- a Proper handling, storage and disposal of combustible materials, liquids and wastes.
- b Work operations which can create fire hazards.
- c Access for firefighting equipment.
- d Type, size, number and location of fire extinguishers or other firefighting equipment.
- e Inspection and maintenance records of extinguishers.
- f Type, number and location of containers for the removal of surplus materials and rubbish.
- g General housekeeping

17 Site Books

For the purpose of quick communication between the Engineer and the Contractor or his Agent or Representative, Site Books shall be maintained at Site in the manner as described below: -

Any communication, relating to the works may be conveyed through records in the Site Books. Such a communication from one party to the other shall be deemed to have been adequately served in terms of the Contract. Each site book shall have machine-numbered pages in triplicate and shall be carefully maintained and preserved by the Contractor and shall be made available to the Engineer as and when demanded. Any instruction which the Engineer may like to issue to the Contractor may be recorded

by him in the Site Book and two copies thereof taken by the engineer for his record. The Contractor or his Agency or Representative may similarly record in the Site Book any communication he may like to send to the Engineer. Two copies thereof when sent to the Engineer and receipt obtained thereof, will constitute adequate services of the communication to the Engineer.

18 **VOID**

19 **Site Meetings**

Progress and quality evaluation meetings will be held at the site every week. The Contractors senior representative in charge of the project along with his site-in-charge and other staff including staff of approved subcontractors and suppliers as required shall participate in these progress review meetings and ensure all follow up actions. Any additional review meetings shall be held if required, as decided by the Engineer, which also shall be attended by the above-referred representatives.

20 **VOID**

21 **Disposal of Refuse etc.**

21a The Contractor shall cart away from site and deposit where directed by the Engineer all refuse, etc. arising from the Works both as it accumulates, at completion of the Works or at the direction of the Engineer.

21b It is the responsibility of the Contractor to obtain a certificate from the local authorities concerned to the effect that all rubbish arising out of Contractor's activities at the construction site or any other offsite activities borrow pits and / or disposal area(s) has been properly disposed off.

This certificate from the authority shall be dated not later than the (last) Certificate of Completion of Works and is to be enclosed with the Payment Certificate in which the Contractor requests for payment of any Retention money due to him.

22 **Contractor to verify site Measurements**

The Contractor shall check and verify all site measurements whenever requested by other specialists, Contractors or by nominated or other sub-contractors to enable them to prepare their own shop drawings and pass on the information with sufficient promptness, as will not in any way delay the works. A copy of all such information passed on shall be given to the Engineer.

23 **VOID**

24 **VOID**

25 **Approved Makes / Agencies**

The Contractor shall provide all materials from the list of approved makes or as mentioned in BOQ and also appoint the specialist agency from the approved list / BOQ as provided in the Tender. The Architect / Employer may approve any make / agency within the approved list / BOQ after inspection of their samples / mock-ups and after ascertaining their spare capacities and recent past performances.

The items which are not covered in the List of Approved Makes shall be as per Samples approved by the Architect.

Colours or type if not mentioned elsewhere shall be as approved by the Architect.

26 **VOID**

27 **Procurement of Materials**

The contractor shall make his own arrangement to procure all materials required for the work unless otherwise specified elsewhere to be supplied by Employer / Owner. All wastages shall be to the contractors account.

28a **Excise & Sales Taxes, Works Contract Tax for Works**

The Contractor shall pay and be responsible for payment of all taxes, duties, levies, royalties, fees or charges in respect of the works including but not limited to sales taxes, tax on works contract, excise duties and octroi, payable in respect of materials, equipment, plant and other things required for the Contract. All of the aforesaid taxes, duties, levies fees and charges shall be to the Contractor's account and Employer shall not be required to pay any additional or extra amount on this account. Variation of taxes, duties, levies, fees etc., if any, till completion of work shall be deemed to be included in the accepted rates & no extra claim on this account will in any case be entertained.

28b **New Taxes, Duties & Levies, etc.**

However, if a new Tax or Duty or Levy is imposed under as statute or law during the currency of the contract, and the same shall be borne by the Contractor.

29 **General Price Variation Adjustment (PVA)**

The Contractor's final quoted price as accepted by the Employer shall remain firm during the entire contract period including authorized extension period. There shall not be any price variation for any reason whatsoever.

30 **VOID**

31 **Guarantee and Maintenance during Defect Liability Period.**

In pursuant to Clause No. 34 of GCC, the contractor shall guarantee all materials furnished and workmanship for a period of 365 days from the date of virtual completion of work i.e during Defect Liability Period. All failed parts or parts exhibiting unusual wear and tear during guarantee period shall be replaced without any cost to the Owner, and such replacement shall be factory approved new, equal or better than original. All labour, tools, materials, transportation, insurance etc., required in performance of guarantee work shall be at the contractor's expense.

32 **VOID**

33 **VOID**

34 **Project Execution and Management**

In pursuant to Clause No. 14 (i) of GCC, the Sr. Representative shall be assisted by adequate number of Engineers / Supervisors at site on full time basis.

For quality control and monitoring of workmanship, contractor shall assign at least one full time engineer who would be exclusively responsible for ensuring strict quality control, adherence to specifications and ensuring top class workmanship.

35 **Tools and Tackles**

All tools, tackles, supports, scaffolding and staging etc. required for erection and assembly of the equipment and installation covered by the contract shall be provided by the Contractor himself. In addition, all other materials such as foundation bolts, nuts etc. required for the installation of the equipment shall also be provided by the contractor at his cost.

36 **Void**

37 **Safety Precautions**

37a A competent and authorized supervisor shall be on the site whenever the contractor's men are at work. The supervisor should ensure that all plant and machinery used on the site are rendered safe for working and meet with the Indian or International safety standards applicable for the use and operation of such machinery. The supervisor should also ensure that the workmen at site are made to use safety appliances such as safety belts, lifelines, helmets etc.

37b Smoking shall be altogether strictly prohibited in all areas of work as well as where combustible and inflammable goods / materials are stored or lying about.

37c Any hot job such as welding, soldering, gas cutting shall not be carried out without the permission of the Engineer. Such jobs shall not be carried out where inflammable materials are stored or lying about.

All electric connections shall be through adequately sized mechanically protected cables without any joints and with proper and adequate terminals boxes. All power supplies shall be through properly rated fuses with isolating devices. No such hot jobs shall be carried out on holidays and without the presence of the Contractor's Supervisor and Owners permissions.

37d It is entirely the responsibility of the Contractor to practice the principles of 'SAFETY FIRST' during the entire tenure of work with adequate insurance covering injury or death to workmen, loss by theft or damage to materials and property and third party.

37e The Contractor should clear the site of all debris every day to avoid accidents. In case this is not done, the Owners may engage necessary labour to maintain the cleanliness of the premises and removal of debris and recover all or part of the expenditure so incurred from the Contractor.

37f Contractor shall at his own cost ensure that all of his personnel, employees, work men and other associated persons working with him at site are adequately insured as per labour laws and statutory provisions. The Contractor shall be responsible for all injuries / damages to men, materials and properties etc. which may arise from the operations or negligence of himself and / or his sub contractors and indemnify the Owners for all such expenses which shall be solely to contractor's own account.



37g Contractor shall at his own cost, provide and maintain a full-fledged first-aid-box to give immediate medical aid to the workers / supervisory staff, in case of emergencies.

37h The contractor shall carry out the work strictly as per the safety aspects.

38 Technical Audit

The whole of the work may be technically audited by the Chief Technical Examiner (CTE) of the Central Vigilance Commission, Government of India from time to time. Any defects, improvement or testing etc. conveyed by the Examiner shall be carried out by the contractor at no extra cost, to the satisfaction of the CTE. Any deduction suggested by the CTE either due to faulty workmanship or not adhering to the specification will be effected.

The Employer shall have a right to cause a technical examination and audit of work and running and final bills of the contractor including all supporting vouchers. Abstract, etc. to

be made at the time of the bill. If as a result of this examination or otherwise any sum is found to have been overpaid in respect of any work done by the contractor under the contract the contractor shall be liable to return the amount of over payment and it will be lawful for the employer to recover the same from any sum or sums due to him and in any other manner legally permissible and if it is found that the Contractor was paid less than what was due to him under the contract in respect of any work, executed by him under the contract, the amount of such under payment shall be duly considered / paid by the employer.

Any sum of money due and payable to the contractor (including security deposit returnable to him) under this contract may be appropriated by the Employer and set off against any claim of the Employer for the payment of a sum of money arising out of or under any other contract made by the Contractor with the Employer.

The brand / make mentioned in the following list should be used by the Contractor and rate quoted should be based on the same. In case of the brand / make is not available, materials of other makes should be used with prior approval of Architect and Bank. The rates will be revised, based on the difference in basic rates of the make brand / name mentioned below: -

List Of Approved Makes For Civil, Carpentry & Electrical & Airconditioning Works		
Make / Specification Detail		
Sr. No.	LIST OF NOMINATED MATERIALS & SUPPLIERS	SUGGESTED MAKE LIST
1	INTERIOR WORK	
	Commercial Plywood	Century / Duro Mac/ SAMRAT or equivalent
	Laminated sheet	Royal touch / Greenlam /SUNMICA
	Veneer	Century / Duro Mac/ GREENPLY or equivalent
	Particle board (only for modular w/s & storage Unit)	Century / Duro Mac/ GREENPLY or equivalent
	Acrylic sheet	ICI, GE or equivalent ISI make
	Marine grade plywood	Century / Duro Mac/ GREENPLY or equivalent
	Adhesive	Fevicol / Araldite/EURO or equivalent
	Solid Surfaces (Curion)	DUPOINT/HI-MAC/ STARON OR equivalent
	Marine grade Block Board	Century / Duro Mac/ GREENPLY or equivalent
	Flush Door	Century / Duro Mac/ GREENPLY or equivalent



Polish	Asain / Dulex or equivalent
Latex	Sleepwell, Kurl-On, Century
High density foam	Sleepwell, Kurl-On, Century
Locks	Haffle / Hettich / Ebco or equivalent
Storage Hardware	Haffle / Hettich / Ebco or equivalent
Screws / Nails & other accessories	GKW / Nettleford or equivalent
False Flooring	Kebao , Armstrong , AMF or equivalent
Vinyl Flooring	Armstrong ,gerflor, Eurotex
Carpet	Unitex, Armstrong
Wooden laminated flooring	Pergo / Armstrong / Euro / Square feet or equivalent
Plain/Toughened glass	Saint- Gobain, Indo Asahi , Modi or equivalent
Hardware for general staff areas	Dorma / Ozone / Enox / Ebco or equivalent
Hardware for main Glass doors (patch fittings)	Dorma / Ozone / Enox or equivalent
Door Closers (general use)	Dorma / Ozone / Enox or equivalent
Floor springs (general use)	Dorma / Ozone / Enox or equivalent
Floor springs for main glass doors	Dorma / Ozone / Enox or equivalent
Aluminium Sections for Partitions	Jindal / Tata steel or equivalent
False Ceilings: Gypsum	India Gypsum / Saint Gobin / Asia
False Ceilings: Grid (As Approved)	Armstrong / Saint Gobin
False Ceilings: Grid (Metal Ceiling)	Armstrong / Saint Gobin
GI Sections	India Gypsum / Saint Gobin / Jindal or equivalent
Acoustical False Ceilings: Mineral fiber board	Armstrong, Hunter Douglas / Peritex or equivalent
POP Punning	Gyprock / India Gypsum / Birla
Paint	Asian / Nerolac / Dulex / Berger or equivalent
Exterior Paint	Asian / Nerolac / Dulex / Berger or equivalent
ACP (Exterior / Interior)	Alstone / Eurobond / Alucobond
Cylicon	G E / Dow corning / Wacer
Rolling / Vertical Blind	Vista / Peritex / Winfab / MAC or equivalent
Frosted Film	3M (Scotchcal 7725 - 324)



	Aluminum Skirting - 50mm	Jindal or equivalent
	Water Proofing	Pidilite or equivalent
	HardWood	Salwood / Teakwood/Kapoor
	Automated Rolling Shutter	Gandhi Automation/Toshi Automatic Systems/Akash Rolling Shutter
	Glass	Saint Gobin / equivalent
2	Plumbing	
	CP Fitting	Jaquar /Hindware or equivalent
	Sanitary Ware	Hindware / Cera / Parryware or equivalent
	Sanitary Fittings	Jaquar /Hindware
	Geyser	Bajaj / Sphere Hot / Crompton /Racold / V Guard / Havells
	Stainless Steel sink	Nirali / Diamond or equivalent
	C.I. Pipe	Bengal Iron Corporation or equivalent ISI make
	Urinal Partition Glass	Merino / Saint Gobain/ Modi / Asai
	GI Pipe	Tata/ Jindal / Zenith or equivalent
	CP Fitting	Prince /Astral or equivalent
	PVC & CPVC Pipe	Prince /Astral or equivalent
3	Civil Work	
	Ceramic Tiles/vitrified homogeneous glazed tiles.	HR Johnson, Kajaria, Nitco,ASL or equivalent
	Cement	Ultratech , ACC , JK Cement , Ambuja
	Chemical Pasting (Tiles)	Pidilite , Fosroc , Eurokart
	Steel	Sail ,Tisscon , Ispat , Tata

List Of Approved Makes For Civil, Carpentry & Electrical & Airconditioning Works		
Make / Specification Detail		
Sr. No.	LIST OF NOMINATED MATERIALS & SUPPLIERS	SUGGESTED MAKE LIST
1	Electrical	
	Light Fittings	Philips / Wipro / Crompton G.
	MCCB, MCB , RCCB, DB, ICTPN TP, HRC Fuse, cahnge over switch, switch fuse Unit	L&T, Legrand, Schneider
	FRLS insulated Elec. Wire/ cable armourd, unarmourd, Sheathed, unsheathed, flexible LT cable, Multi core, single core cable, flat cable	Finolex/Polycab /RR kabel



	PVC conduit(HEAVY DUTY ONLY)	Finolex/Polycab
	PVC insulated copper conductor Wires	Finolex/ Polycab/RR Cable
	Distribution Box	Legrand/ Schneider/ L&T
	MCB & MCCB	Legrand/ Schneider/ L&T
	Light Fixture & Lamps	Philips/ Wipro/ Crompton G.
	HT cable	Polycab/Havells
	Modular Switches	Legrand/ Schneider/ Crabtree
	DLP Trunking	Legrand/Schneider or equivalent
	Power cable	CCI/ Skytone/ Universal/ LAPP/ Torrent
	End Termination	Raychem/ Mahindra/ELMEX
	PANEL	Crompton/L&T/ Legrand
	Fan	Crompton/Havells/ Almonard
	Raceway & Alu. Trunking	Tata/Jindal/Zenith
	Casing Caping	Finolex/Cap or equivalent
	Weather proof socket outlet with MCB	ABB/MDS/LEXIC/Neptune/Elcon- Clipsil, Siemens, Schneider (Merlin Gerin)
	Miniature Circuit Breaker	ABB/MDS/LEXIC/ Clipsil/Siemens/HPL
	Earth Leakage Circuit Breaker	MDS/LEXIS/Siemens/HPL
	MCB Distribution Boards in sheet steel housing (double door)	ABB/MDS/LEXIC/Siemens/HPL
2	Distribution	
	MV Contractor/Timer/Relays/Starters	Legrand/ Schneider(MG) /L&T
	Moulded case circuit breakers	Legrand/ Schneider(MG)/ L&T
	SFU/Fuses	HPL/ L&T. Siemens, GE Power, Schneider (MG)
	ACB	Schneider(MG)/ Siemens/L&T
	Single Phase Preventer (Current base)	L&T, Minilec
	Raising Mains & Tap Off (Power coated)	Zeta, C&S, Siemens
	MV Switchboards (Powder Coated)	Tricolite Electrical Industries, conlec Enginners Pvt. Ltd, Vidyut Control Pvt Ltd., Trinitron Milestone Switchgear, Unilec Ltd, Madhu Electrical Advance Electro Control Pvt Ltd.
3	Low Tension System	
	Light & Fan Wire	Polycab, Finolex, Havells
	Telephone Wires	Delton, Skyline, Finolex, Rallison, Batra Henley



	Telephone Tag Blocs	Krone / Pouyet/ TVS
4	Cables and Accessories	
	1100Volts grade Cables	CCI, Universal, Fort Gloster, Polycab, RPG (Asian), Nicco
	Cable Lugs	Dowells
	Cable compression Glands	Peeco/ Comet
	Cable Trays / Cable ladders	Slotco, Bharti, RICCO, Pilco, MM Enterprises
5	Metering & Protection	
	Cast Resin current transformers	Gilbert Maxwell, Kappa AE, Precise
	Meters (Digital)	L&T Roshab, Automatic Electric, Siemens, Socomex
	Selector switches	HPL/L&T Salzer, Kaycee
	Indication lamp	L&T Vaisno Teknic
	KWH Electronics Digital Meter	Secure, L&T, Enercon, Socomec- HPL
6	EPABX	
	Exchange/ Console Panel	Copper connection, Flash Hymax, Accord CG, Tata Telecom, Panasonic
	CVT	Logicstat, Blue Bird, Selvon, Max Power
	UPS	HPL- Socomec, Tata Liebert, APC, Invensys, Copper Connection
	Hand Set	Beetel, Tataphone, Crompton
	Tape off	Cat Vision, Shyam
7	Electrical Items	
	Panel Switch Gear & related Item	
	LT Panel/Bus Duct	By any Panel manufacturer who process C.P.R.I. certificate for specified fault level & IP level protection
	Fuse Disconnecter switch/switch fuse unit	L&T/ Schneider/Legrand
	Ammeter Voltmeter	AE/L&T/MECO/Rishab
	Digital Meters/ Intelligent Multifunctional Digital meter	AE/HPL/CONZERV
	Selector Switch, Push button switch / emergency switch	KAY CEE/ L&T/ Siemens/ Schneider
	Indication Lamp	AE/L&T/Siemens/ Schneider
	CT's	L&T / AE/ Kappa
	AT's	L&T/ Schneider/ legrand
	Voltage stabilizer for air conditioner (4/5KVA)(170-270V)	V Guard/Microtek



	Air Conditioner - Split Inverter AC(5 star) - (.75 ton -1ton,1.5 ton,1.8ton-2ton)	(HITACHI, CARRIER, DAIKIN)
	Air Conditioner - Cassette Inveter AC(5/4/3 star) - (2.9 ton - 3.5 Ton)	(HITACHI, CARRIER, DAIKIN)
8	Transformer	
	Distribution Transformer	Jindal / Areva/ Muskan/ Alstrom
	11 or 33 KV VCB	Crompton/ Alstom
	HT Termination & Jointing kit	Ray Chaem / Mahindra/ ELMEX
	Cable Glands	Dowells / Siemens/Braco
	Lugs & Thimbles	Dowells / Johnson
	Upto & including 11KV cables (ISI markes)	CCI/ Skytone/ Gloster/ Havells
	Insulating Mats	ISI Marked
	Capacitor Bank (ISI marked)	GE Power/ BHEL/EPCOS/ L&T
	Lightning Arrestor	Altas/ Alstom/ GE power
	Protection & Other Relay	ABB/ Siemens/ Schneider/ L&T/ Allen Bradley
9	Internal Wiring Related Works	
	MCB/RCCS/Isolators (ISI) marked MCB DB	L&T/ Schneider/ Legrand
	PVC Conduit	CAP / BEC/ Seiko/ AKG
	PVC insulated copper wire (ISI marked)	Finolex/ Havells/ Ploycab
	Telephone Cable	Skytone/ Delton/ NICCO/Polycab/ Finolex
	Switch, TV & Telephone socket & boxes (Modular Type)	Crabtree/ Legrand/Schneider
10	Miscellaneous Items	
	Lightning Protection Unit	Erico/ Pheonix/ INDELEC
	Relays	L&T/ ABB/Siemens/BCH
	Contractors	L&T/ GE Power/BCH/ Siemens/ ABB
	Changeover switch	L&T/ Schneider/ Legrand
	KWH, PF, Frequency meter	BHEL/ AE/Havells/ L&T/ ALSTOM
	Push Buttons	L&T/ Siemens
	Timers	L&T/ Legrand/ Schneider/Siemens/GE
	Timer Switch	L&T/ Legrand/ Schneider/Siemens/GE
11	Networking	



Switches	Brocade/Cisco/Digi-Link/3Com/Nortel/Foundry/DLink
Patch Panel,Patch cord and I/o	Digi-Link / Tyco(AMP) /Schneider/D-Link
Cable	Digilink/Clipser/National/Polycab/Lapp/Finolex
Racks	ComRack / HCL / ValRack / APW President
Light fittings	
	PHILIPS MAKE - Smart Glow - 600 mm x 600 mm - 25W.
	PHILIPS MAKE - Green LEDi - 7W and 12 W
	PHILIPS MAKE - Line Light- 28 W.

Note:

[a] Where other Material are proposed to be used these should be got approved from the Architect/Bank's Engineer before execution of particular item. In case of Non- Availability of any material of specified make, the Alternative equivalent make should be used only after it is approved in writing by the Employer or the Architect. The Material shall be used in preferential Order only.

[b] Before starting of work, contractor must get all samples/make approved from Architect/Bank's authorities before using at site.

[c] Consultants/Bank's authorities reserve the right to add or delete name of any manufacturers and when required.

[d] Consultants/Bank's authorities reserve rights to select any of the specified brands mentioned above.

III. CERTIFICATE

The measurements on the basis of which the above entries for the Running Bill No. _____ were made have been taken jointly on _____ and are recorded at pages _____ to _____ of measurement book No. _____.

Signature and date of contractor

Signature and date of Project Architect

The work recorded in the above mentioned measurements has been done at the site satisfactorily as per tender drawings, conditions and specifications.

Project Architect



Proforma for "Memorandum for Payment" IV

RUNNING BILL NO. _____

- 1. Total amount due since previous bill (D) (A+B) Rs. _____
 - 2. Deductions :
 - i) Secured Advance paid in the previous R.A. Bill Rs. _____
 - ii) Retention money on value of works as per accepted tenders : up to date amount Rs. _____
 Less : Already recovered (-) Rs. _____
 Balance to be recovered Rs. _____ (-) Rs _____
 - iii) Mobilization advance, if any
 - a) Outstanding amount (Principal + Interest) as on date Rs. _____
 - b) To be recovered in this bill Rs.
 - iv) Any other departmental material cost to be recovered as per contract, if any
Rs. _____
 - v) Any other departmental service charges to be recovered if any, as per contract (water, power etc) Enclose statement Rs. _____
- Total deduction as per contractor Rs. _____ (-) Rs. _____
 Net amount payable as per Contract (E-F) Rs. _____ Rs. _____(G)

(Rupees) in words

The bill amounting to(both figures and words) has been scrutinized by me after due check of the measurement of works as required and is recommended for payment.

Signature of Project Architect with seal

Date:

The Project Architect's certification amounting to (both figures and words) has been scrutinized by me and after due test check of the measurement of works as required is recommended for payment amounting to(both figures and words)

Signature of Project Architect's

Date:

STATUTORY DEDUCTIONS :

- 1. Total amount due (E) Rs. _____
 - 2. Less : Income Tax Payable Rs. _____
- Net Payable Rs. _____

The figure given in the Memorandum for Payment has been verified and the bill passed for payment Rs..... (Words and figures)

Date :

Signature of the
DGM, ZIAD Deptt., Rajkot



Proforma V of Certificate of Payment By Bank

Certificate No. Interim/	Dated	
Client :	Project No.	Building Work/Interior Work
	Particulars :	
Contractor :	Contract/Letter NO.	Dated :
	Contractor's Bill No.	Dated :
<p>This is to certify that the amount given below (*) is due to the Contractors for the work done by them and/or against materials delivered at site and/or for advance towards contract on the above referred project.</p>		
Advance against contract		Rs. _____
Less : Advance adjusted to-date		Rs. _____
Balance Advance		Rs. _____
Advance against material delivered at site		Rs. _____
Amount of work done to-date		Rs. _____
Total		Rs. _____
Less : Retention on work done		Rs. _____
Less : Previously certified upto		Rs. _____
PRESENT CERTIFICATE (*)		Rs. _____
RUPEES		
<p>The cost of cement or any other material supplied or payments made by BOB directly, if any and not covered herein above, should be adjusted before making the payment of the certified amount (*) Necessary Deduction U/S 194C of the Income Tax 1961 and sales tax may be made before paying the above certified amount.</p>		
<p>By a copy of this letter, we are intimating the Contractors to call on you for the necessary payment.</p>		
<p>Remarks, if any :</p> <p>The details of Insurance Policy are given in the next page.</p>		
<p>Signature of Project Architect _____</p>		
<p>Enclosures : Bill</p>		

Client's Copy



VI - DETAILS OF INSURANCE POLICIES

Type of policies	Name of Insurance	Amount Rs.	Policy No.	Validity
CAR Policy including 3 rd Party liability		The Insurance shall be for an amount equal to 110% of the contract value.		Till Site handing over to bank
Workmen's Compensation				
Remarks :				
1.	This is only an 'on-account' payment and is not to be interpreted either as approval of work, materials brought or affixed at site or for that matter approval of any sort.			
2.	The quantum of work done and materials delivered at site have been certified by			
3.	Should you wish to audit such work, kindly contact the undersigned and oblige.			
				_____ Project Architect

PROFORMA OF HINDRANCE REGISTER

Name of Work : Date of start of work :
 Name of Contractor : Period of completion :
 Agreement No. : Date of completion :

Sr. No.	Nature of hindrance	Date of occurrence of hindrance	Date of which hindrance was removed	Period of hindrance	Signature SE/PE	Remarks
1	2	3	4	5	6	7

Project Architect

SAFETY CODE

1. First aid appliances including adequate supply of sterilized dressing and cotton wool shall be kept in a readily accessible place.
2. An injured person shall be taken to a public hospital without loss of time, in case where the injury necessitates hospitalization.
3. Suitable and strong scaffolds should be provided for workmen for all works that cannot safely be done from the ground.
4. No portable single ladder shall be over 8 meters in length. The width between the side rails shall not be less than 30 cm (clear) and the distance between two adjacent rungs shall not be more than 30 cm. When a ladder is used an extra Labour shall engaged for holding ladder.
5. The excavated material shall not be placed within 1.5 meters of the edge of the trench of the half of the depth of trench whichever is more. All trenches and excavation shall be provided with necessary fencing and lighting.
6. NO floor, roof or other part of the structure shall be so overloaded with debris or materials as to render it unsafe.
7. Workers employed on mixing and handling material such as asphalt, cement mortar of concrete and lime mortar shall be provided with protective footwear and rubber hand-glove.
8. Those engaged in welding works shall be provided with welder's protective eye shield and gloves.
9. i) No paint containing lead or lead products shall be used except in the form of paste and readymade paint.
ii) Suitable facemasks should be supplied for use by the workers when the paints applied in the form of spray or surface having lead paint dry rubbed and scrapped.
10. Overalls shall be supplied by the Contractor to the painters and adequate facilities shall provide to enable the working painters to wash during the periods of cessation of work.

PROFORMA FOR APPLICATION BY CONTRACTOR FOR EXTENSION OF TIME

1. Name of the Contractor
2. Name of the work as given in the Agreement
3. Agreement WO
4. Tender amount
5. Date of commencement of work
6. Period allowed for completion as per agreement
7. Date of completion as per agreement
8. Period for which extension of time has been given

Dated Month Year

- a) 1st extension vide Bank's Letter No.
 - b) 2nd extension vide Bank's Letter No.
 - c) 3rd Extension vide Bank's Letter NO.
9. Reasons for which extensions have been previously given (copies of the previous applications should be attached)
 10. Period for which extension is applied for and the reasons thereof including hindrances, time for extra work assigned, if any etc.

Signature of Contractor

BIDDER'S PROFILE:

All the supporting Documents are required to be submitted with tenders. Details filled in this form must be accompanied by sufficient documentary evidence, in order to verify the correctness of the information. **All the documents should be attested by the bidder.**

Sr. No.	Description	Bidders particulars
C.1	Name of the Bidder/Firm	
C.2	Permanent Account Number	
C.3	GST No.	
C.4	Registered Office address along with Pin code	
C.5	Email Address	
C.6	Phone/Mobile nos.	
C.7	Name of Director/Partner/Proprietor	
C.8	Name of the person who have power of attorney or Authorized Signatory	

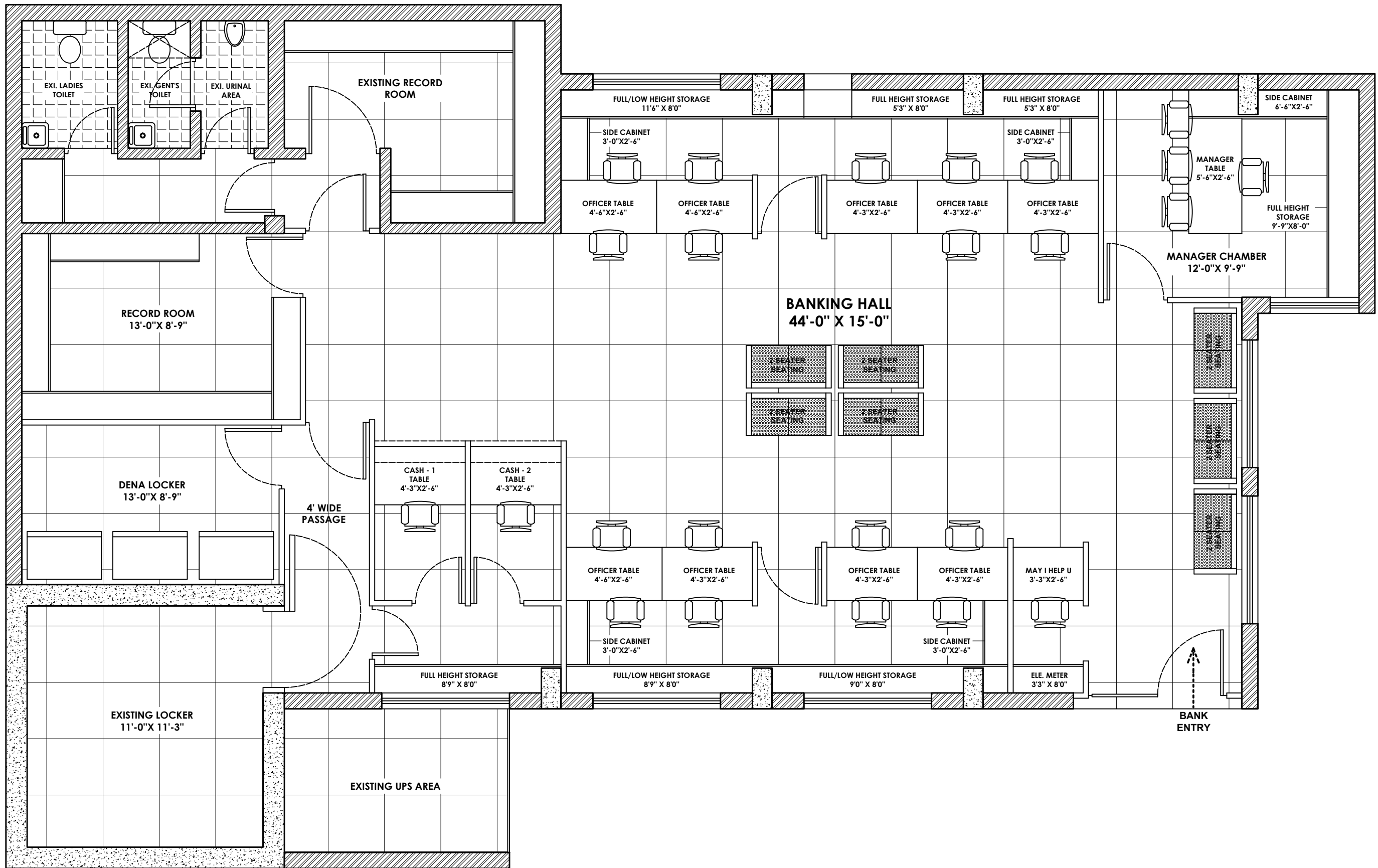

INTERIOR WORK LAYOUT PLAN

NOTE :- CHECK DIMENSION AT SITE BEFORE EXECUTION



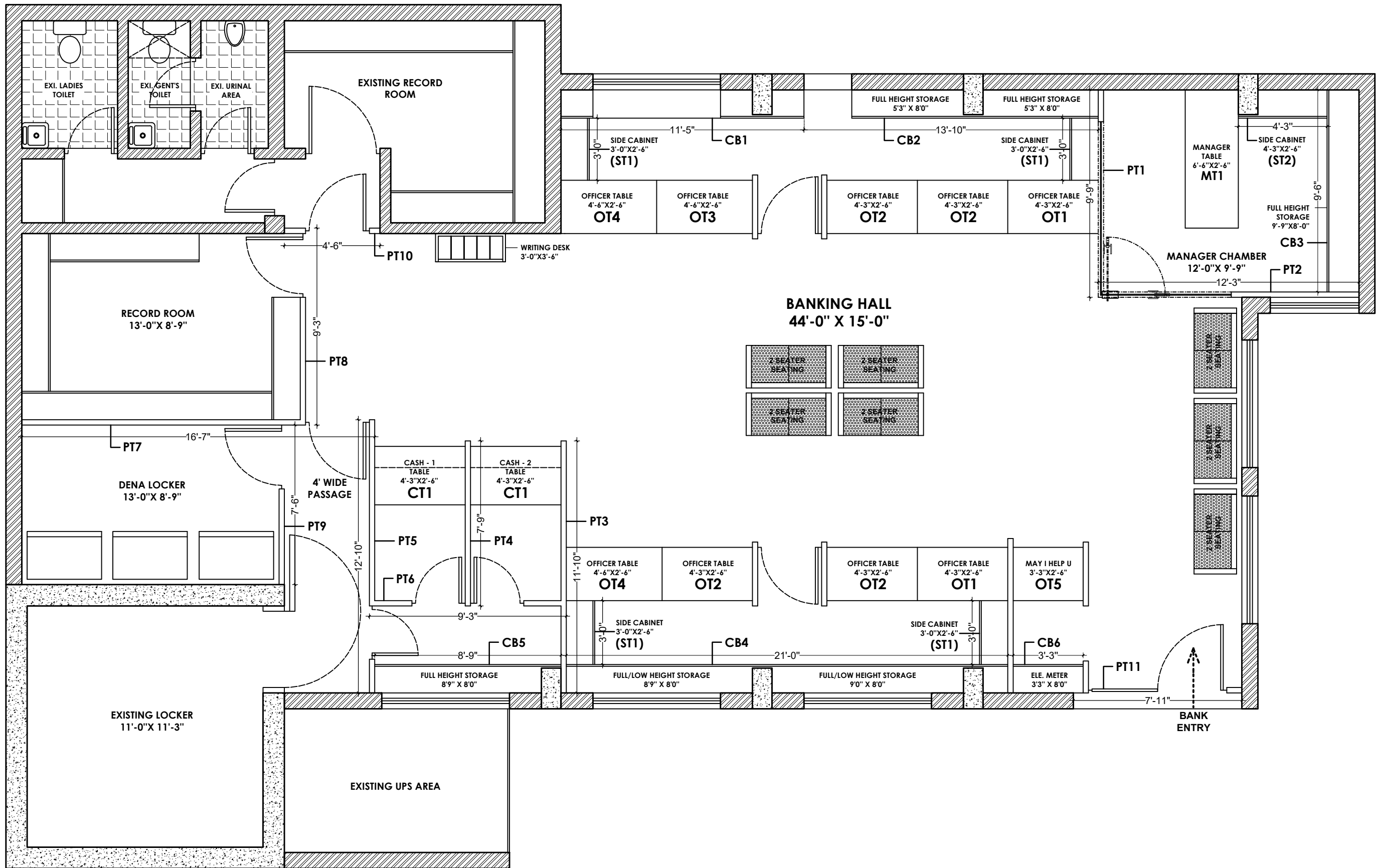

FURNITURE WORK LAYOUT PLAN

NOTE :- CHECK DIMENSION AT SITE BEFORE EXECUTION



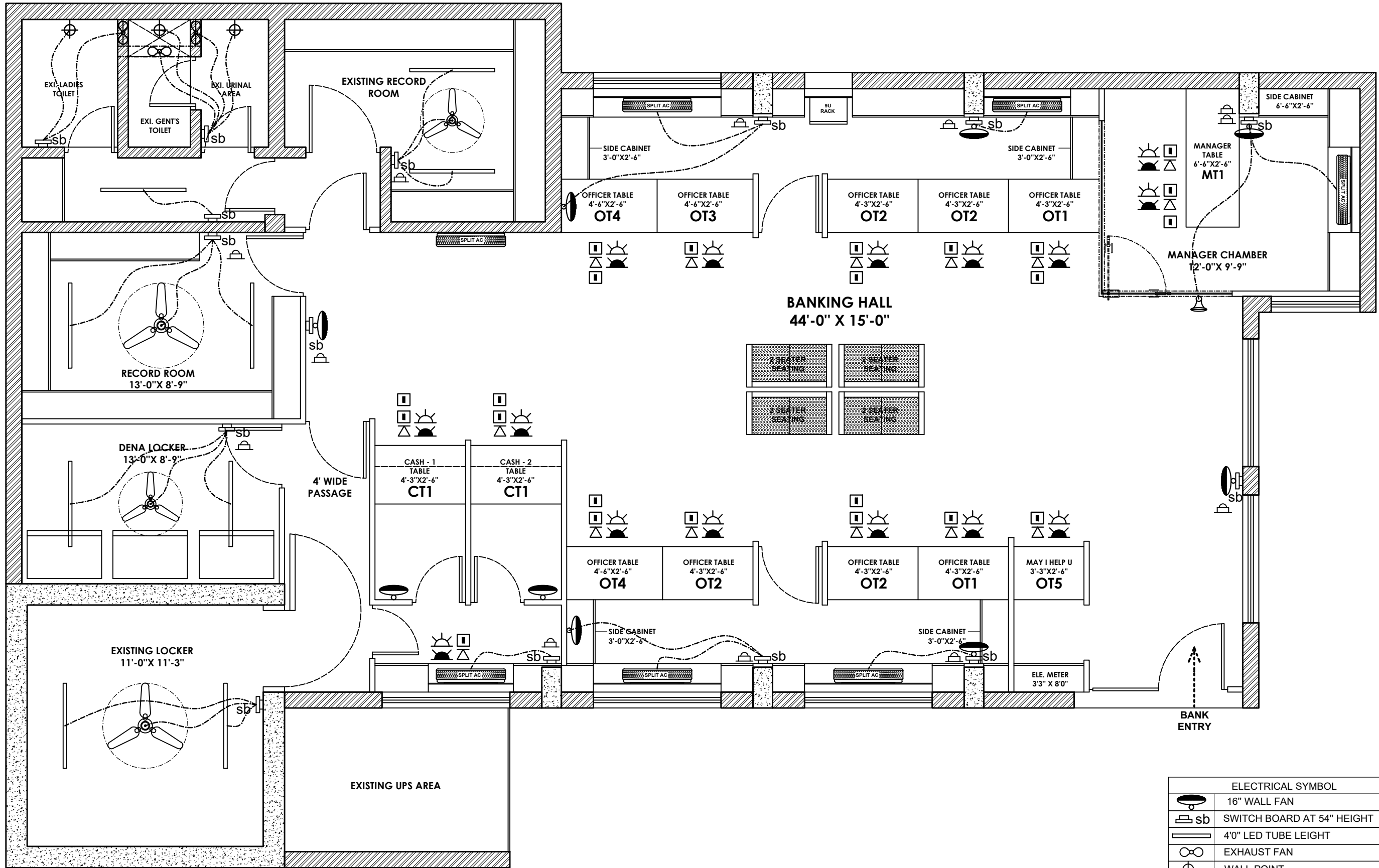

ELECTRIC WORK LAYOUT PLAN

NOTE :- CHECK DIMENSION AT SITE BEFORE EXECUTION

ELECTRICAL SYMBOL	
	16" WALL FAN
	SWITCH BOARD AT 54" HEIGHT
	40" LED TUBE LEIGHT
	EXHAUST FAN
	WALL POINT
	BELL
	5 AMP PLUG POINT
	TELEPHONE POINT
	THREE 5AMP PLUG POINT FOR UPS
	THREE 5AMP PLUG POINT ROW
	D LINK IO FACE PLATE
	15 AMP PLUG POINT
	SPLIT AC

Anil Vadgama
Architect
96241 67971

V n B Designs
Architecture & Interior
e-mail : vnbdesigns@rediffmail.com



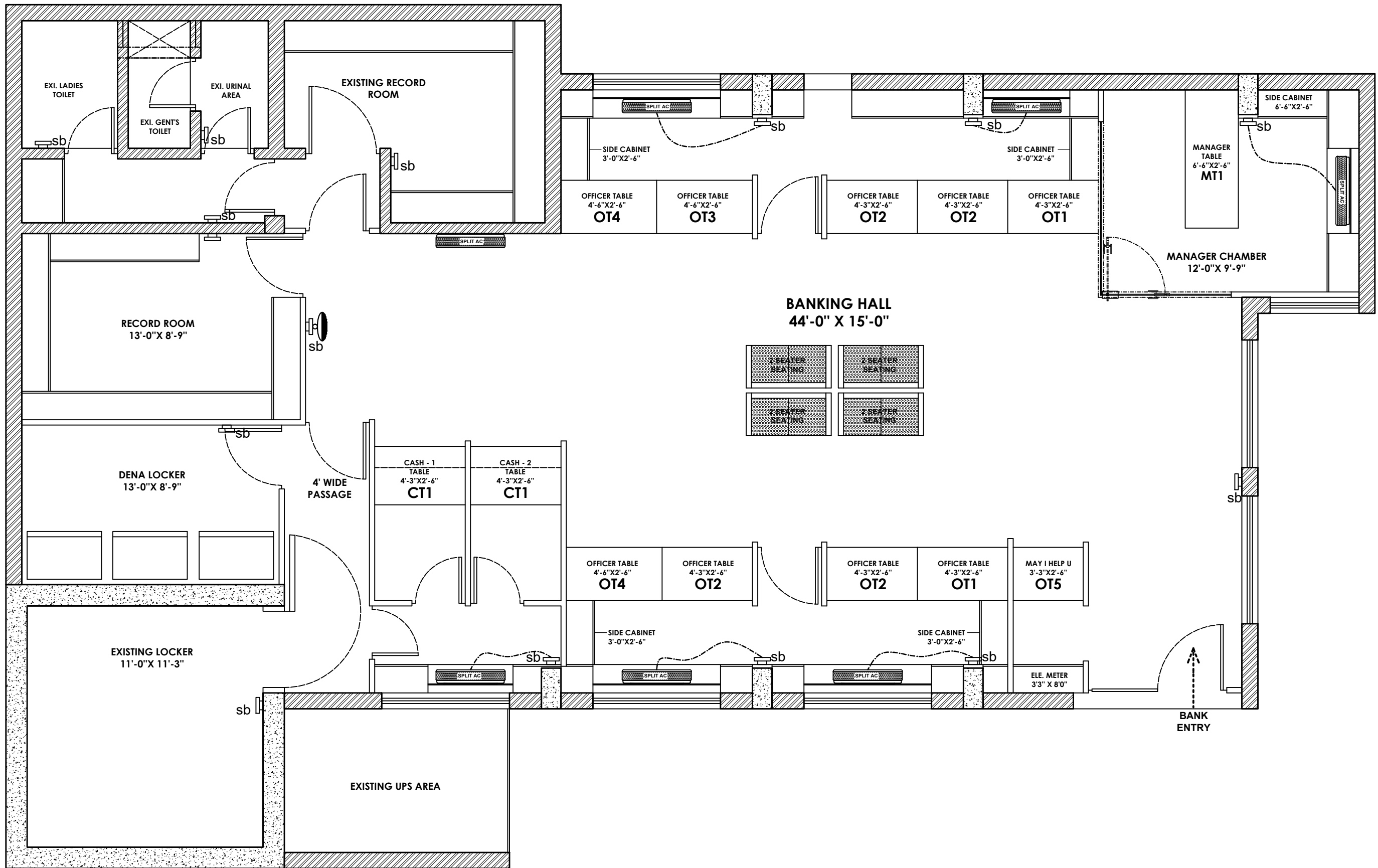

GROUND PLAN; INTERIOR LAY-OUT PLAN
of proposed bank building
for Bank of Baroda , UPLETA BRANCH
UPLETA.

210, nakshatra II commercial complex, opp.k.v.hall,150 feet wide ring road,
rajkot-360 005.



AIRCONDITIONING WORK LAYOUT PLAN

NOTE :- CHECK DIMENSION AT SITE BEFORE EXECUTION

ELECTRICAL SYMBOL	
 sb	SWITCH BOARD AT 54" HEIGHT
 SPLIT AC	SPLIT AC

Anil Vadgama
Architect
96241 67971

V n B Designs
Architecture & Interior
210, raketraira il commercial complex, opp.k.v hall,150 feet wide ring road,
rajkot-360 005.
e-mail : vnbdesigns@rediffmail.com.



GROUND PLAN; INTERIOR LAY-OUT PLAN
of proposed bank building
for Bank of Baroda , UPLETA BRANCH
UPLETA.

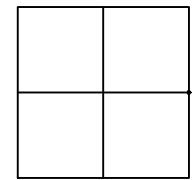
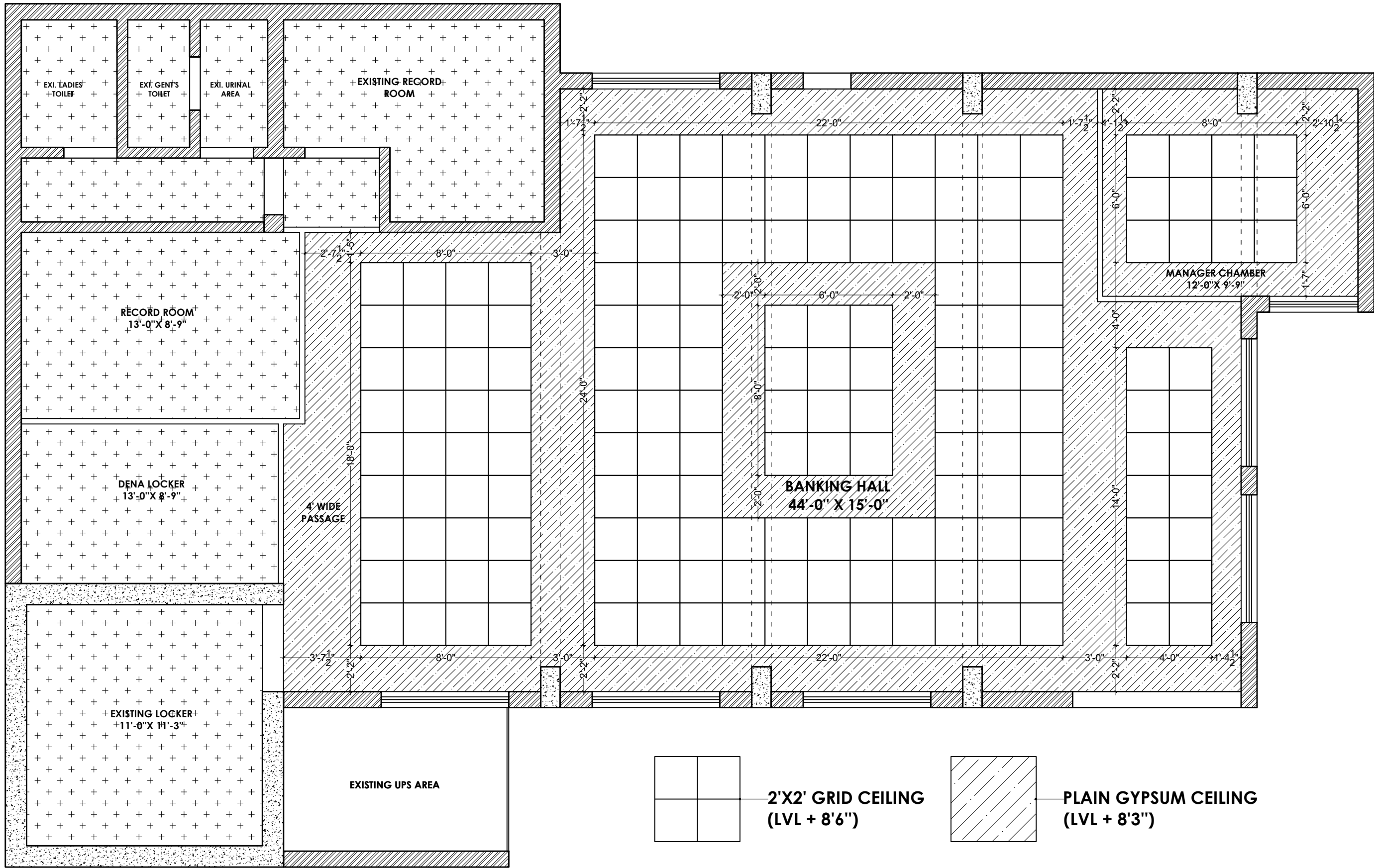

2'X2' GRID CEILING
(LVL + 8'6")

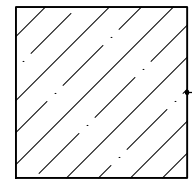

PLAIN GYPSUM CEILING
(LVL + 8'3")

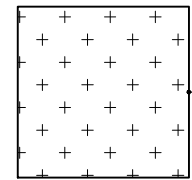

NO CEILING

CEILING WORK LAYOUT PLAN

NOTE :- CHECK DIMENSION AT SITE BEFORE EXECUTION

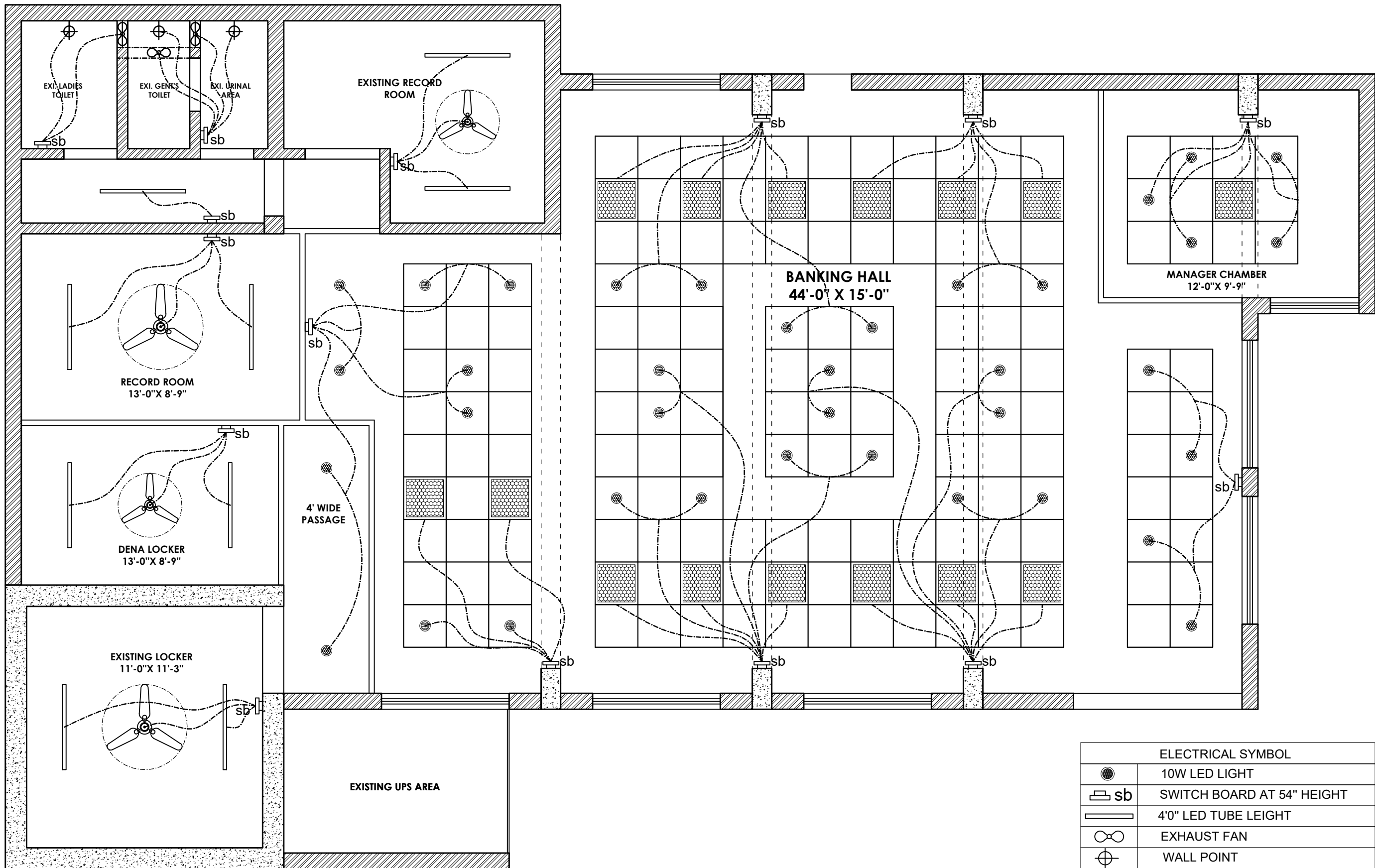

CEILING ELECTRIC WORK LAYOUT PLAN

NOTE :- CHECK DIMENSION AT SITE BEFORE EXECUTION

ELECTRICAL SYMBOL	
	10W LED LIGHT
	SWITCH BOARD AT 54" HEIGHT
	4'0" LED TUBE LEIGHT
	EXHAUST FAN
	WALL POINT
	3'0" & 4'0" CEILING FAN
	2 X 2 LED LIGHT

GROUND PLAN; INTERIOR LAY-OUT PLAN
of proposed bank building
for Bank of Baroda , **UPLETA BRANCH**
UPLETA.

Anil Vadgama
Architect
96241 67971
V n B Designs
Architecture & Interior

210, nakshatra II commercial complex, opp.k.v hall,150 feet wide ring road,
rajkot-360 005.
e-mail : vnbdesigns@rediffmail.com.

Date : 12-12-2024

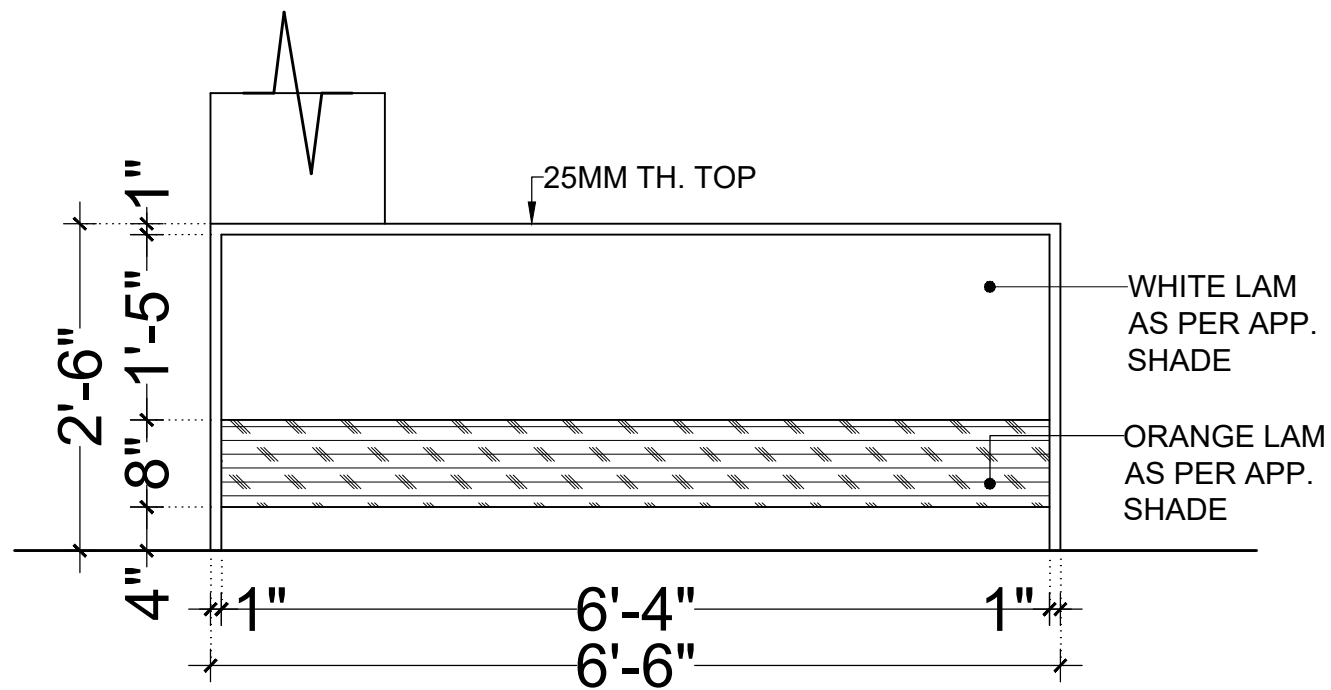

ELEVATION (FRONT) (MT1)

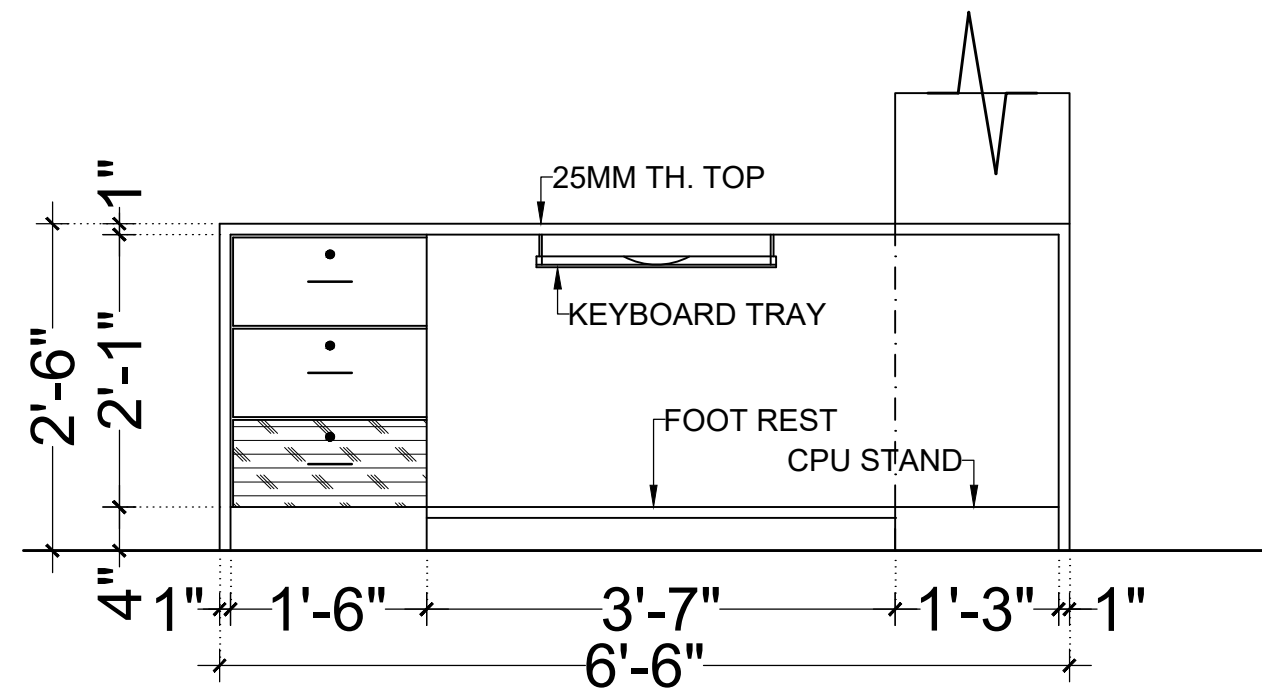

ELEVATION (INSIDE) (MT1)

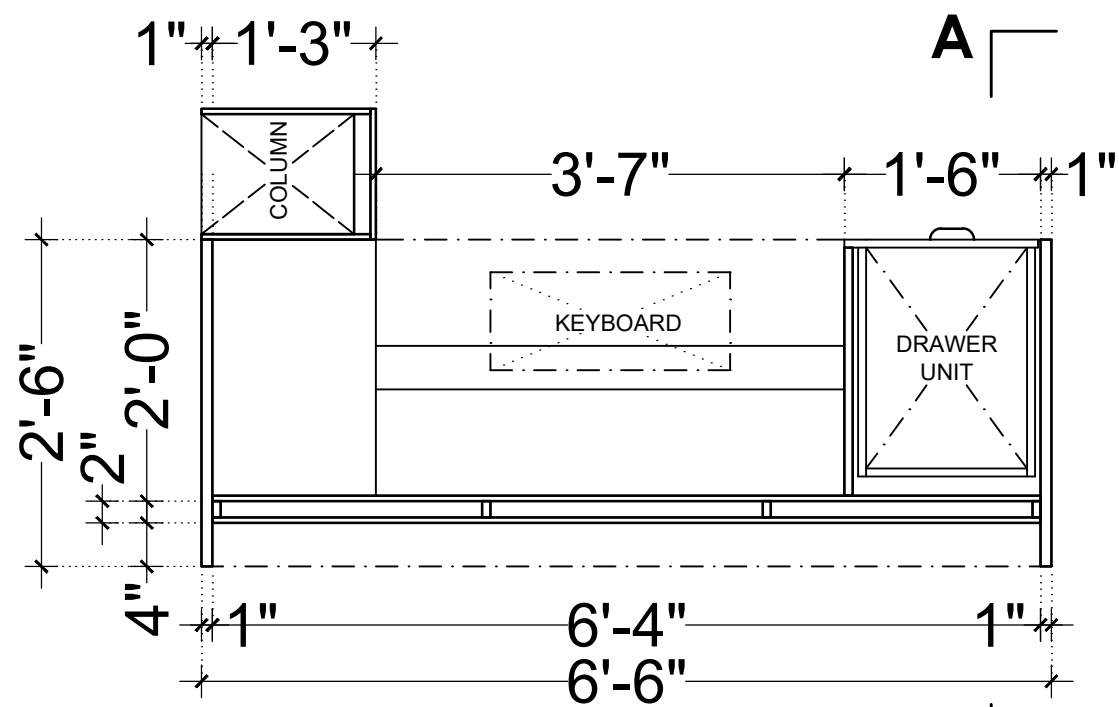

PLAN (LVL + 2'-0") (MT1)

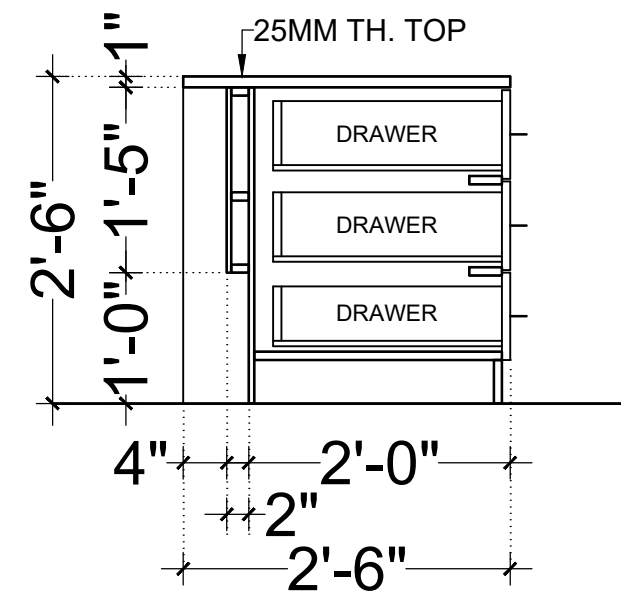

SECTION AA (MT1)

MANAGER TABLE DETAIL (MT1)

NOTE :- CHECK DIMENSION AT SITE BEFORE EXECUTION

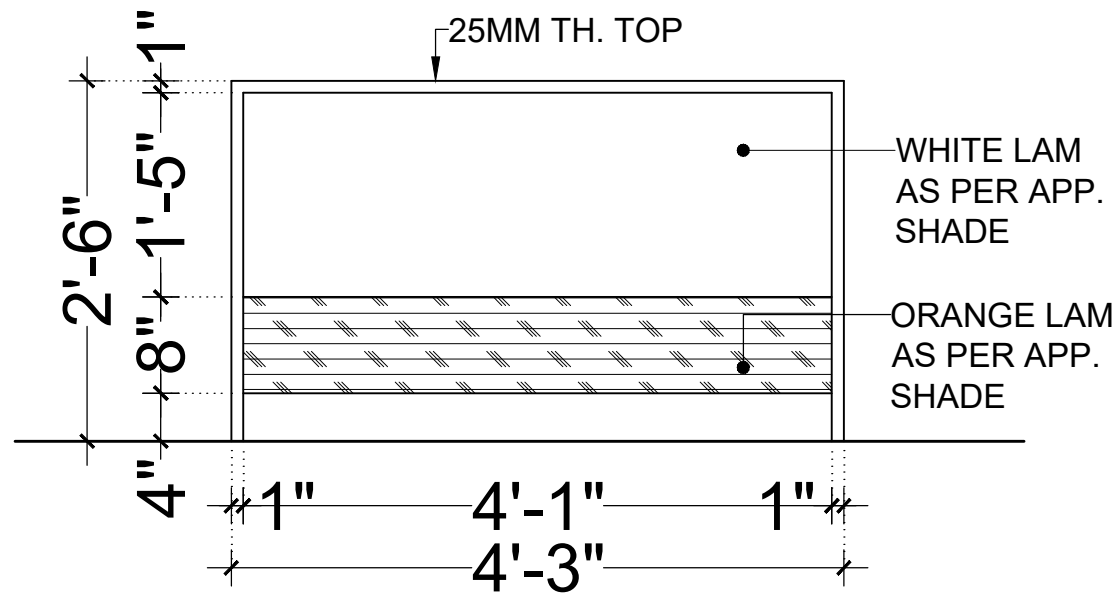

ELEVATION (FRONT) (OT1)

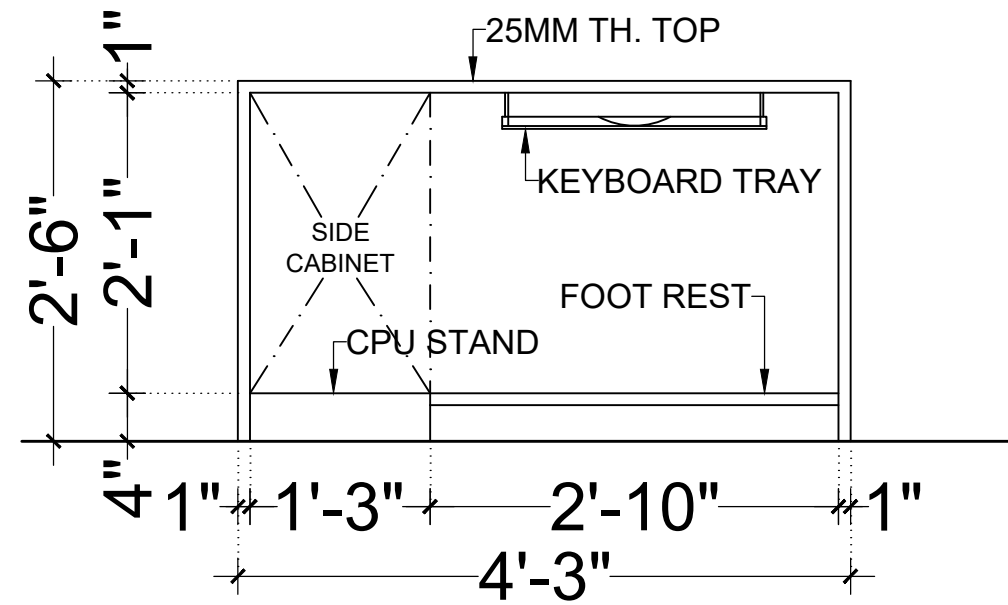

ELEVATION (INSIDE) (OT1)

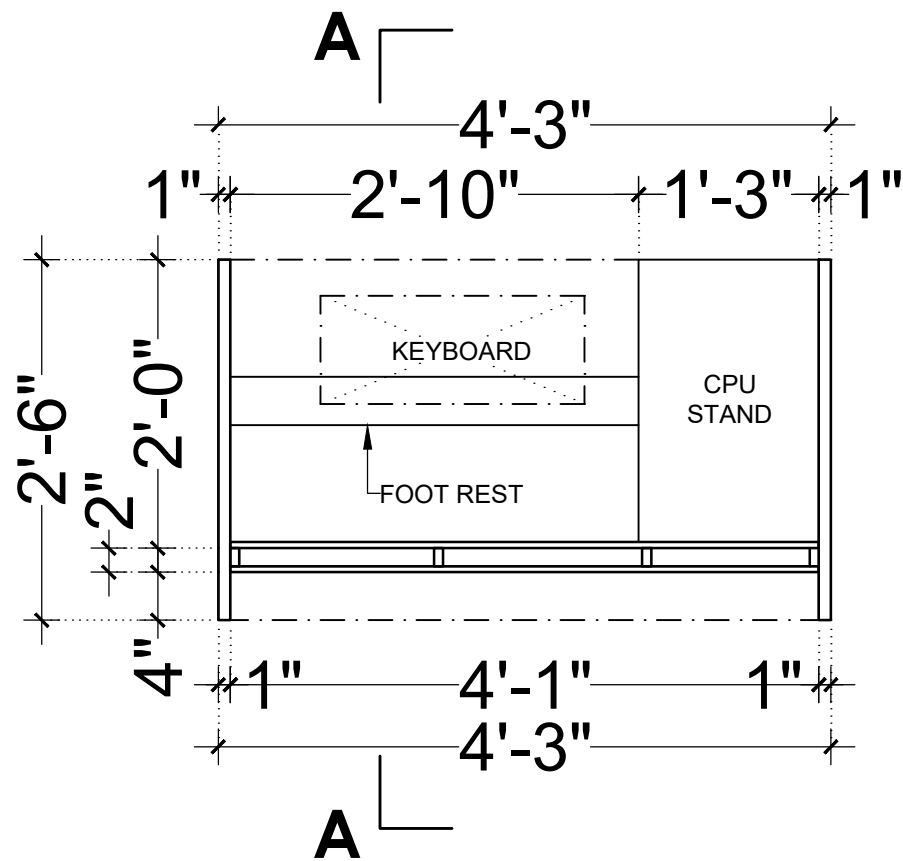

PLAN (LVL + 2'-0'') (OT1)

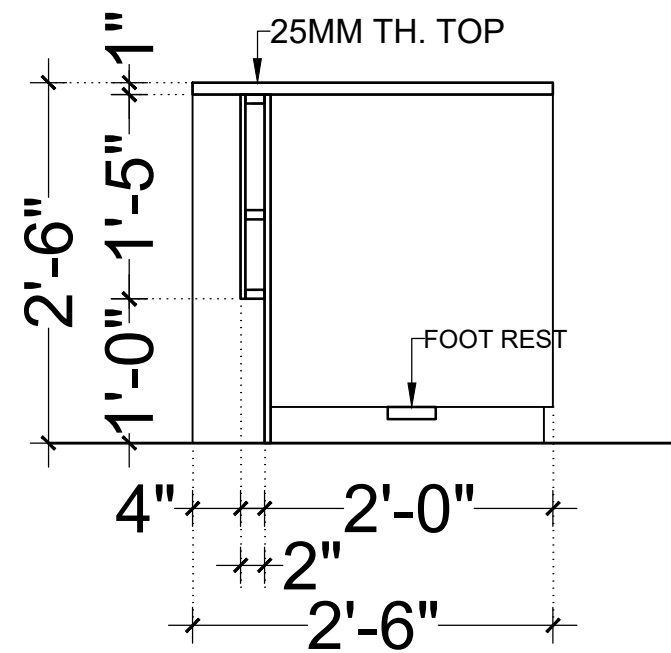

SECTION AA (OT1)

OFFICER TABLE DETAIL (OT1)

NOTE :- CHECK DIMENSION AT SITE BEFORE EXECUTION

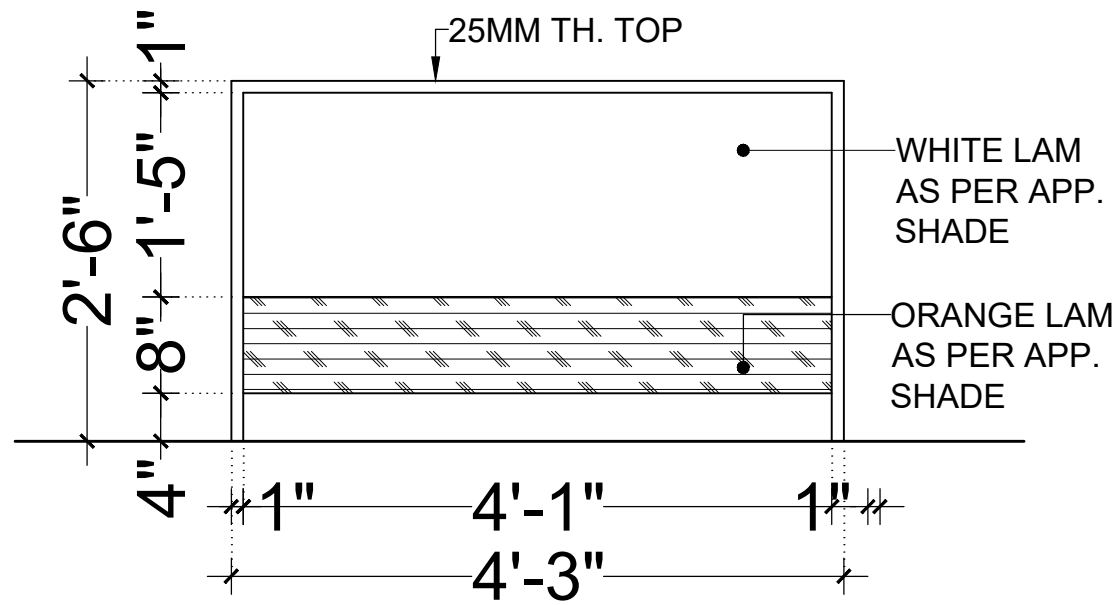

ELEVATION (FRONT) (OT2)

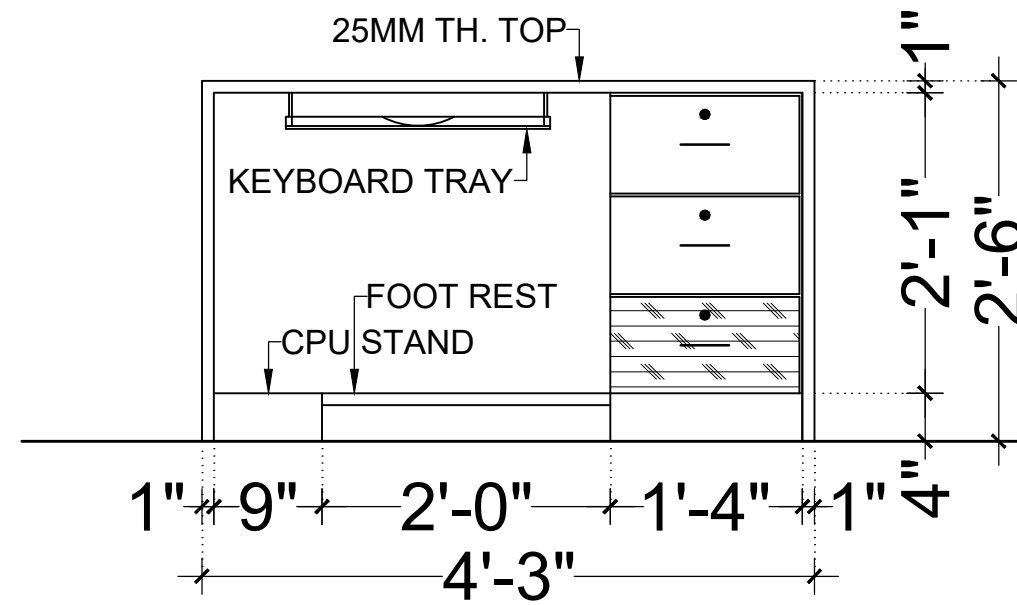

ELEVATION (INSIDE) (OT2)

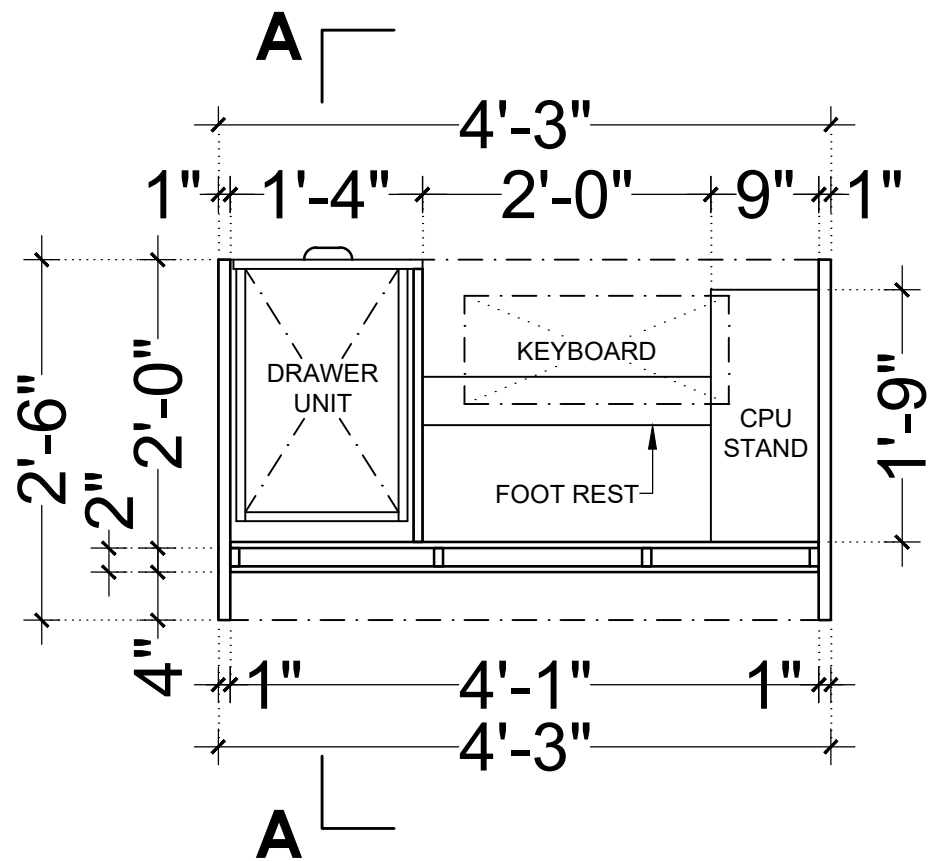

PLAN (LVL + 2'-0") (OT2)

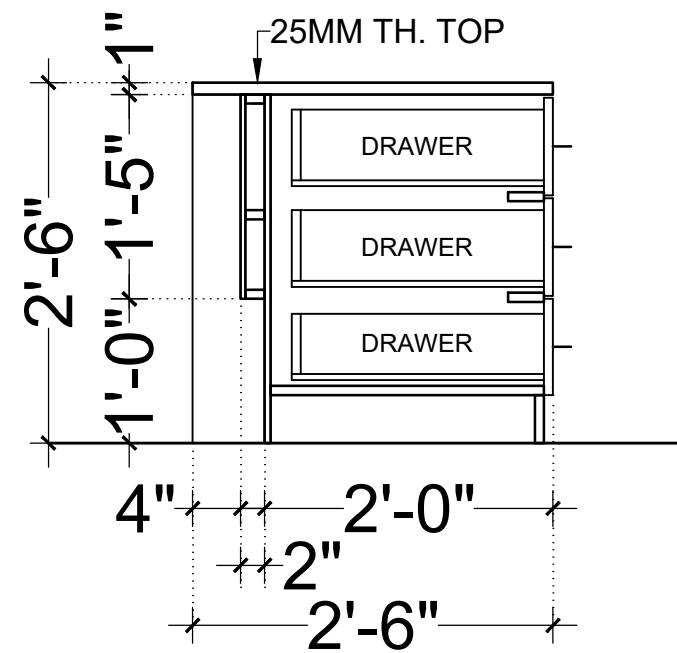

SECTION AA (OT2)

OFFICER TABLE DETAIL (OT2)

NOTE :- CHECK DIMENSION AT SITE BEFORE EXECUTION

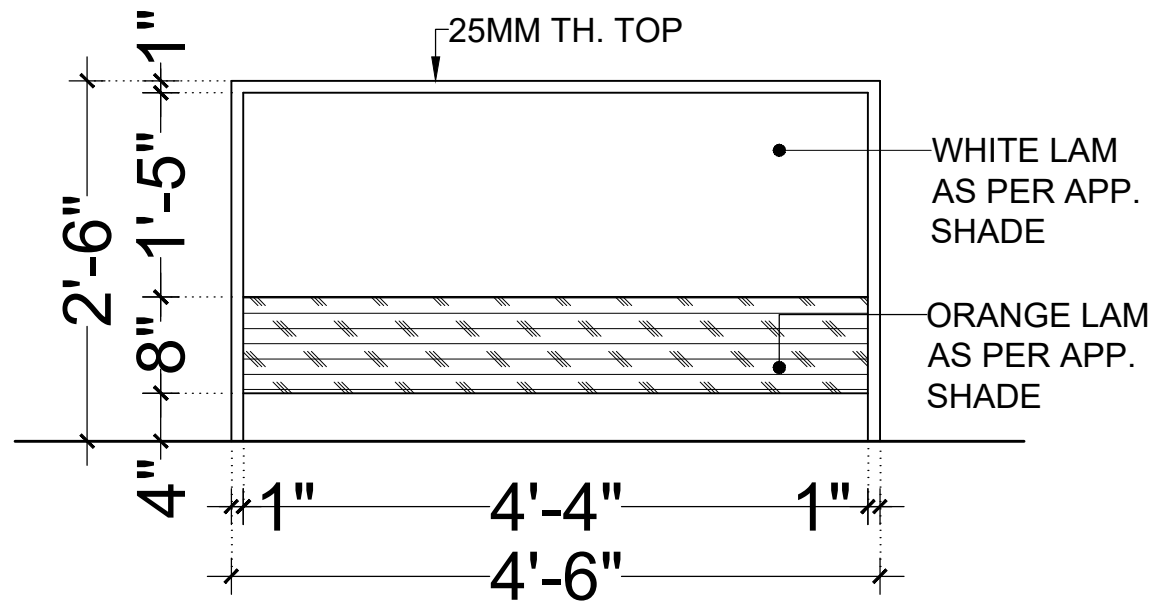

ELEVATION (FRONT) (OT3)

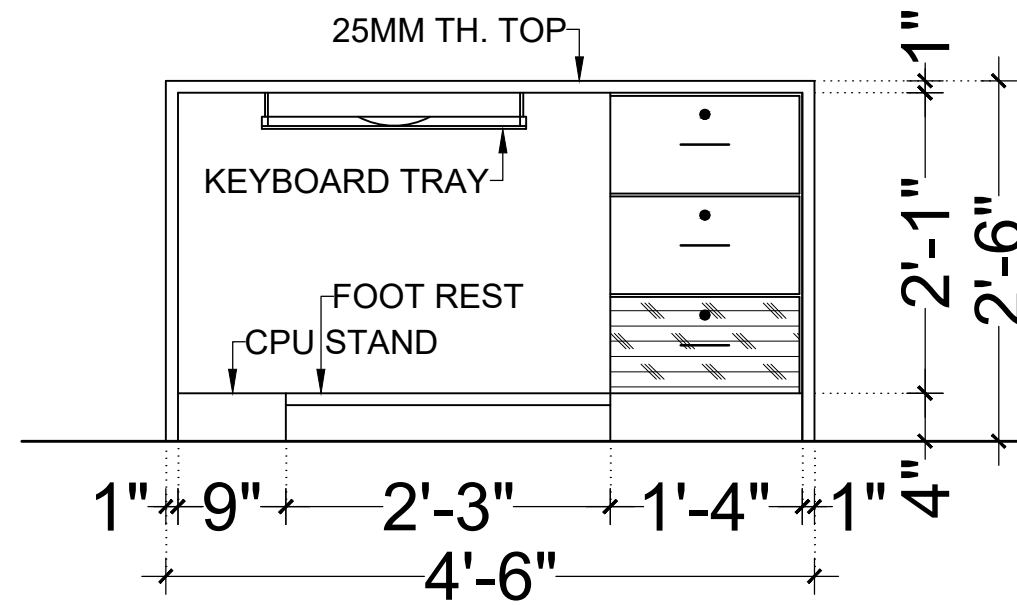

ELEVATION (INSIDE) (OT3)

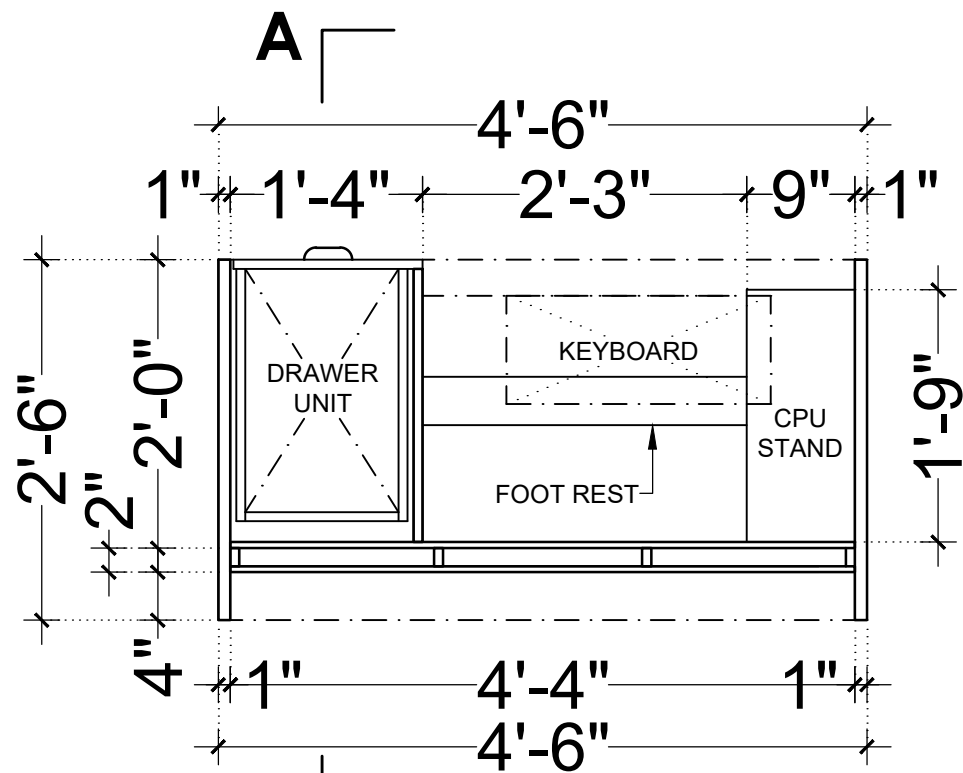

PLAN (LVL + 2'-0") (OT3)

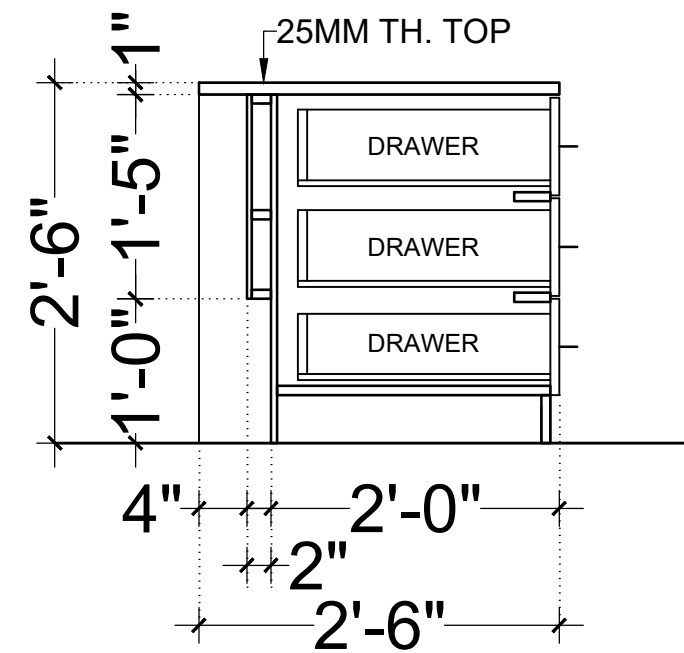

SECTION AA (OT3)

OFFICER TABLE DETAIL (OT3)

NOTE :- CHECK DIMENSION AT SITE BEFORE EXECUTION

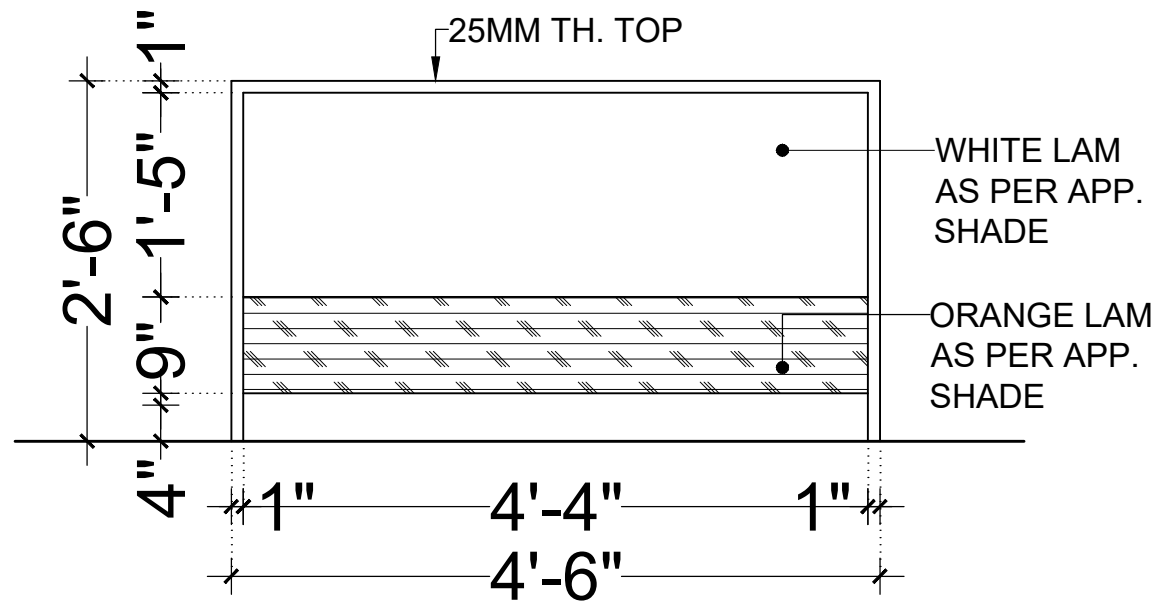

ELEVATION (FRONT) (OT4)

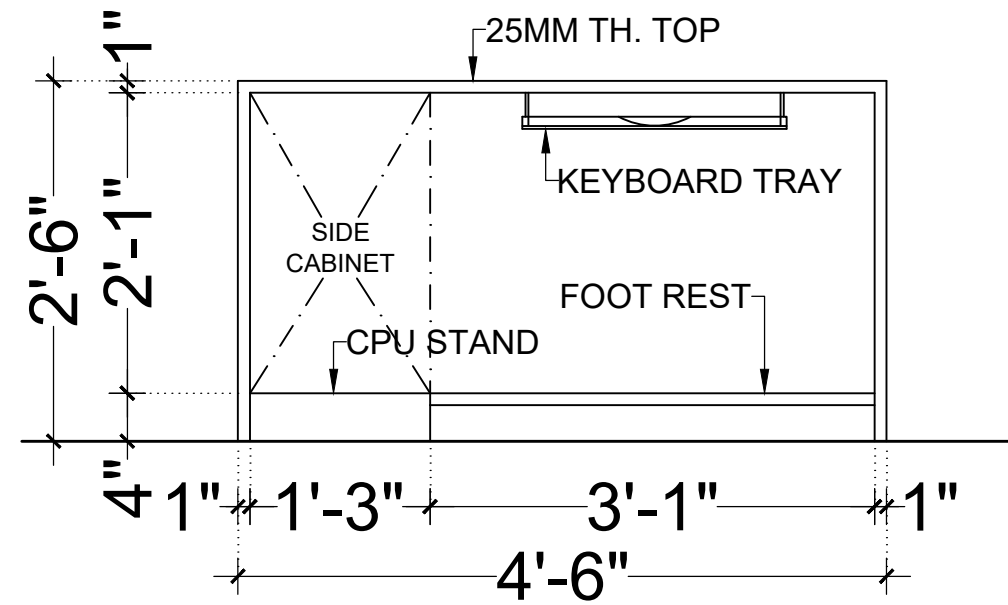

ELEVATION (INSIDE) (OT4)

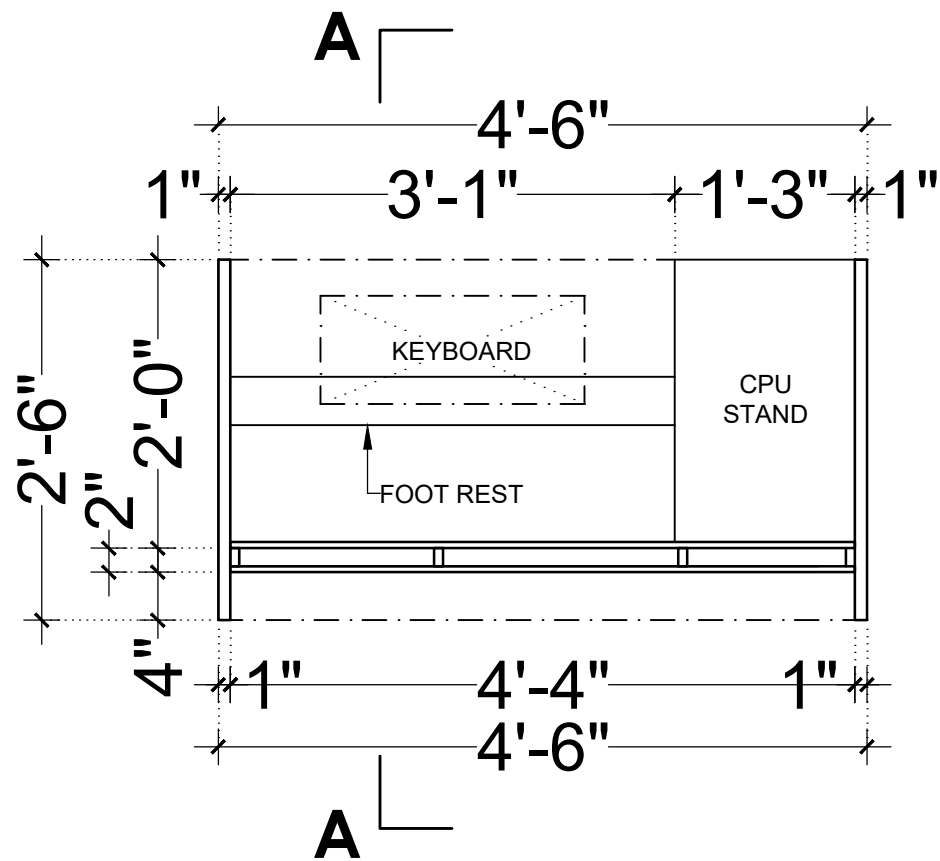

PLAN (LVL + 2'-0'') (OT4)

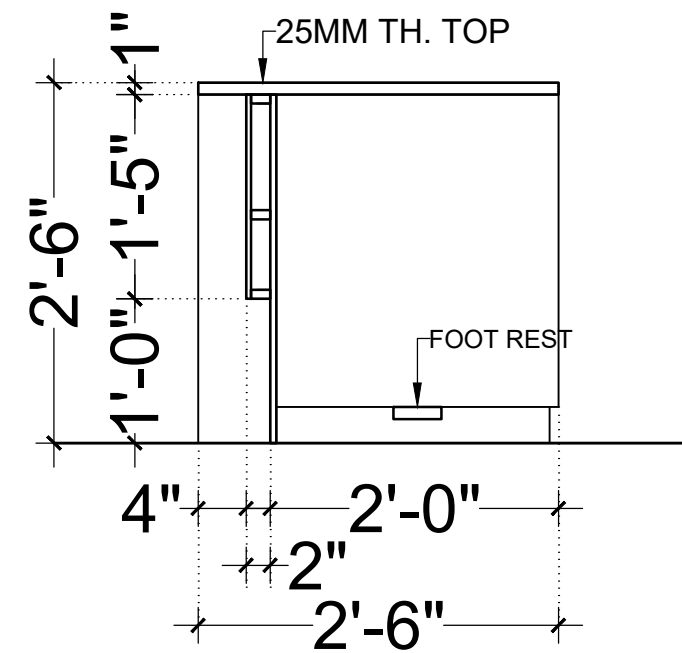

SECTION AA (OT4)

OFFICER TABLE DETAIL (OT4)

NOTE :- CHECK DIMENSION AT SITE BEFORE EXECUTION

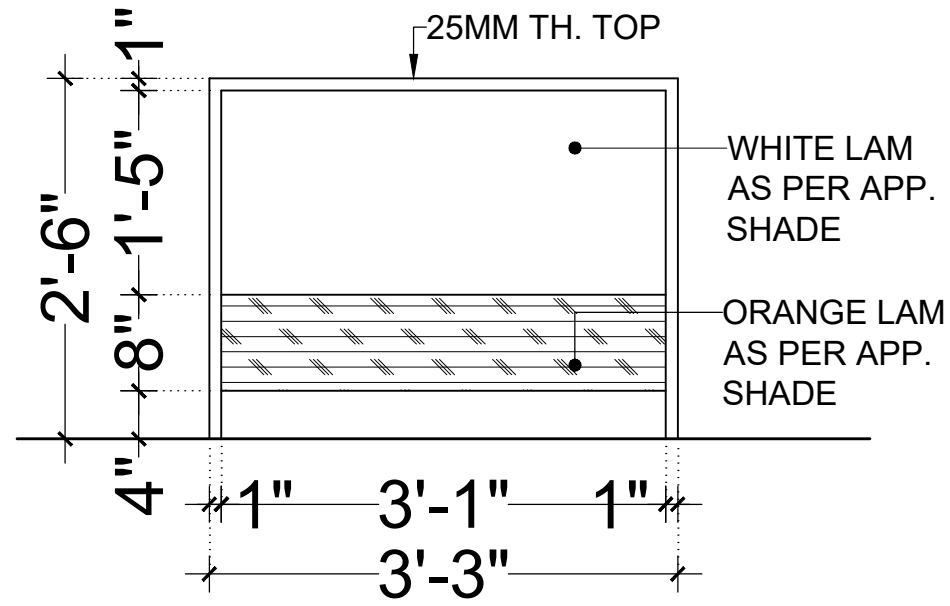

ELEVATION (FRONT) (OT5)

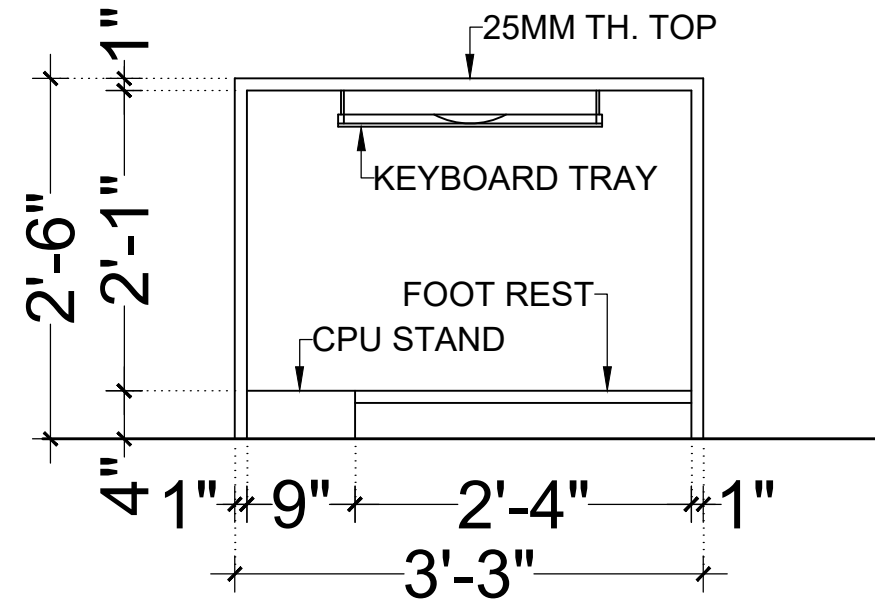

ELEVATION (INSIDE) (OT5)

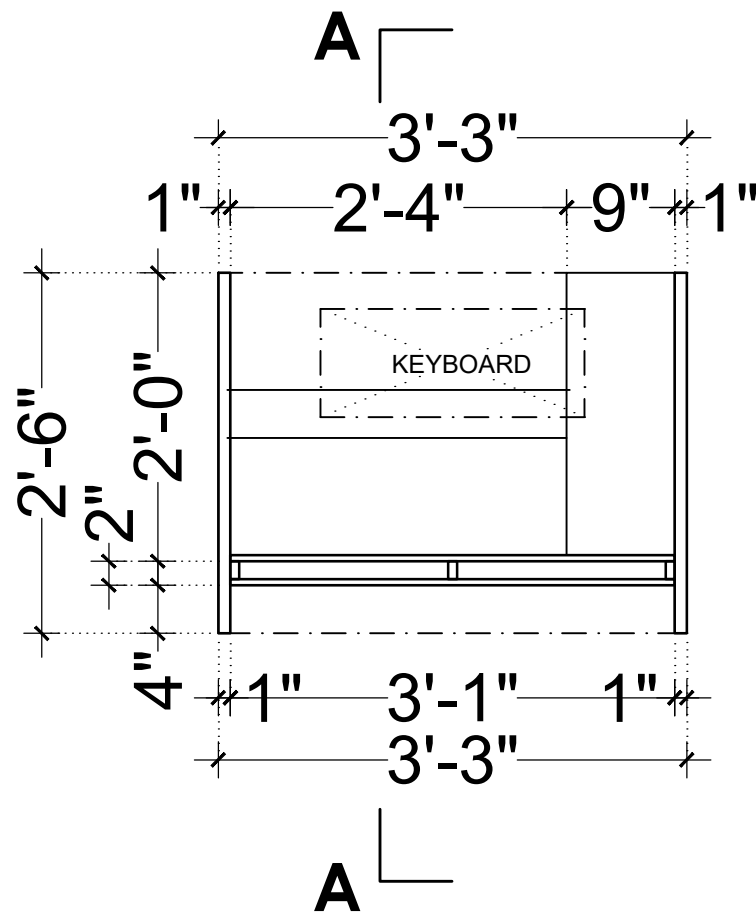

PLAN (LVL + 2'-0") (OT5)

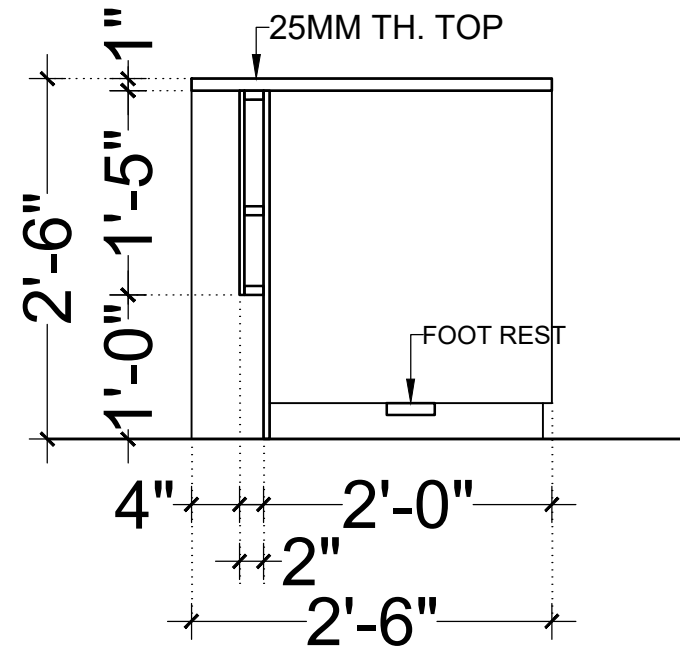

SECTION AA (OT5)

MAY I HELP YOU TABLE DETAIL (OT5)

NOTE :- CHECK DIMENSION AT SITE BEFORE EXECUTION

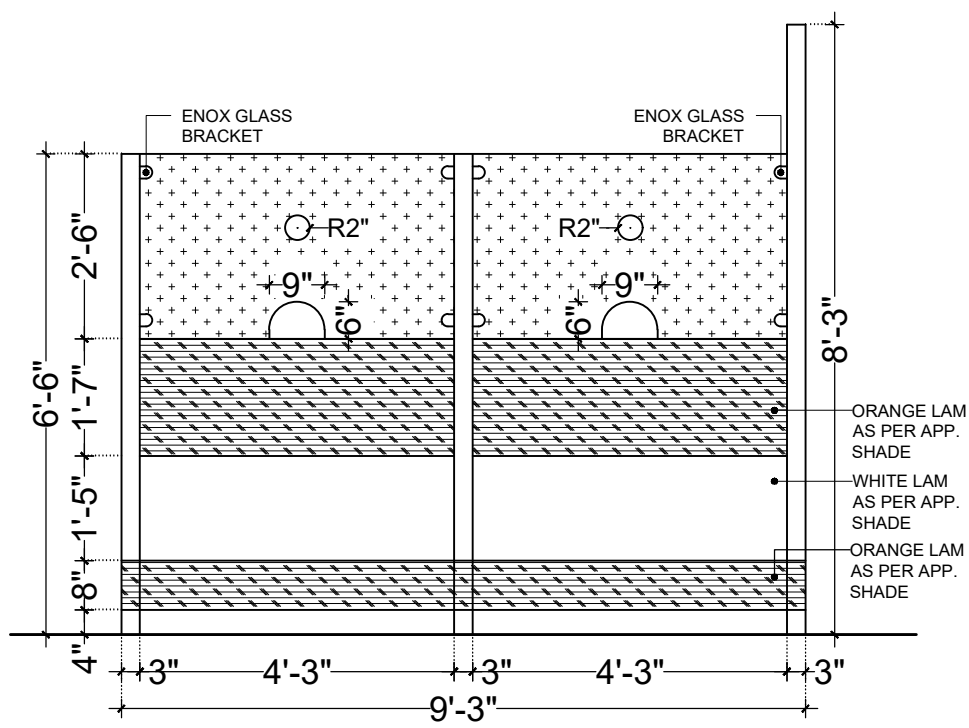

ELEVATION (FRONT)

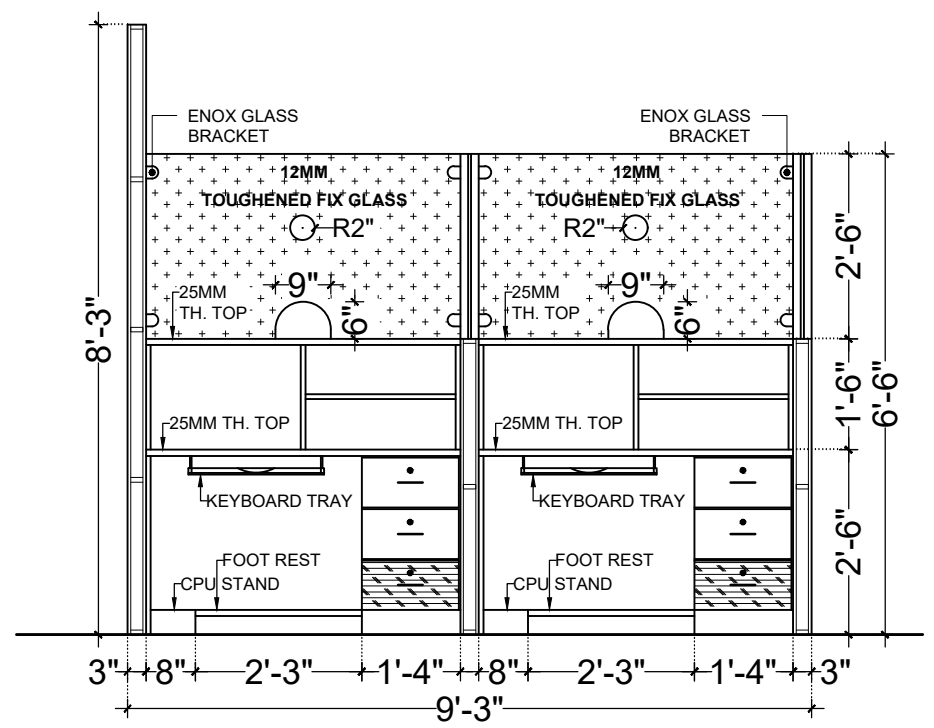

ELEVATION (INSIDE)

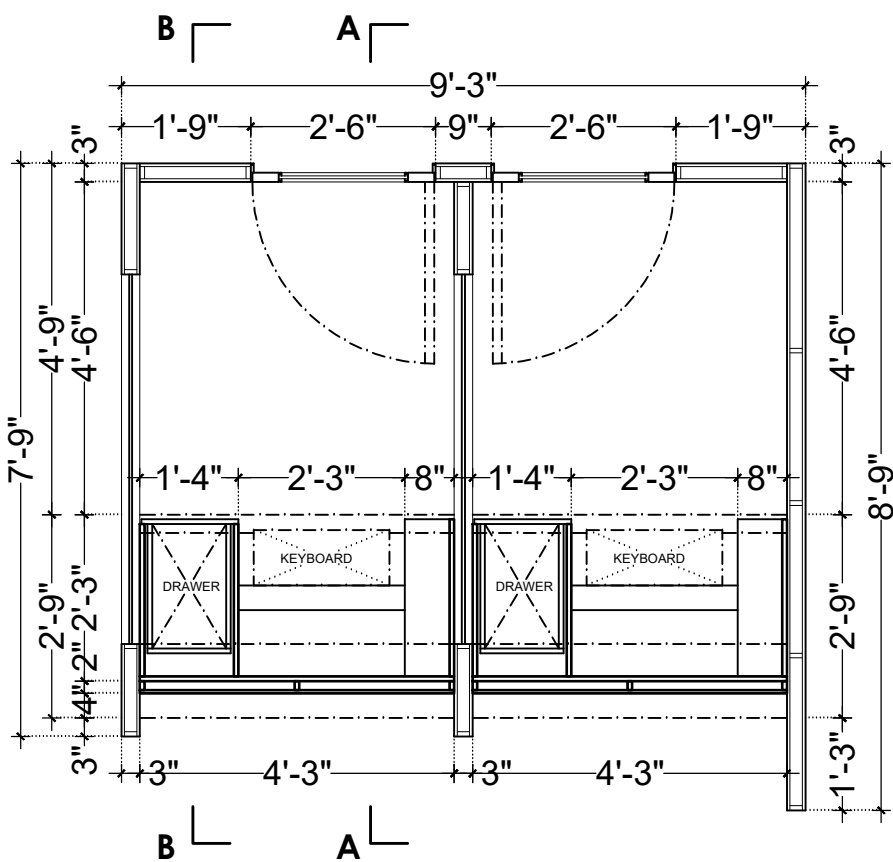

PLAN (CT1-1) (LVL + 2'-0'')

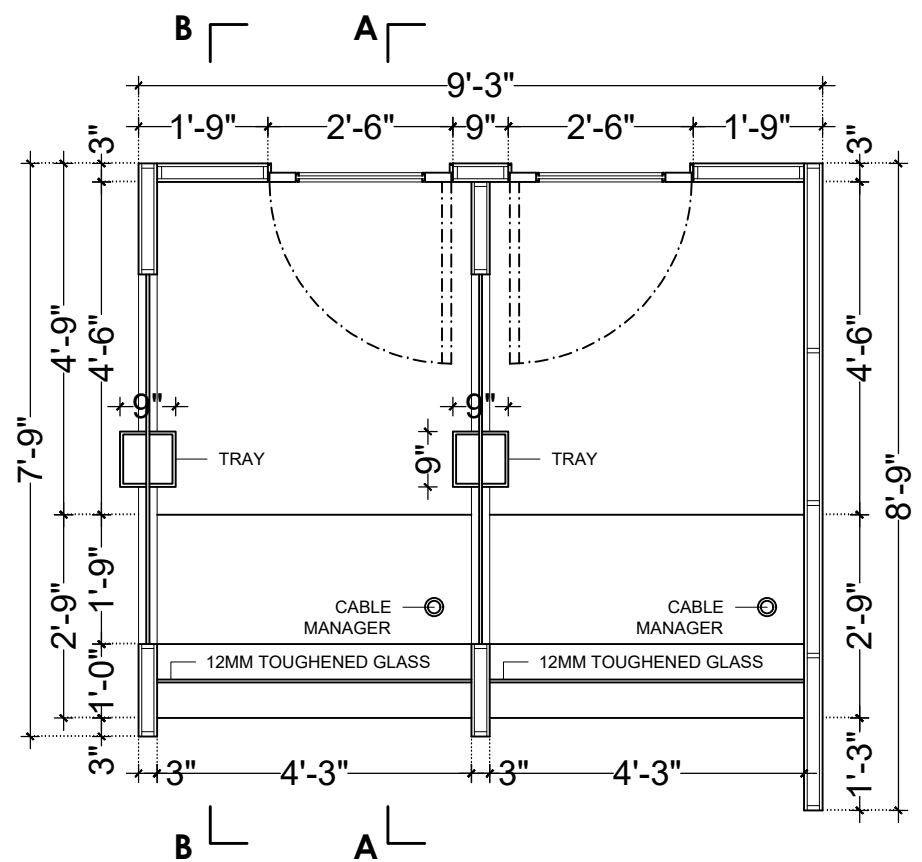

PLAN (CT1-1) (LVL + 5'-0'')

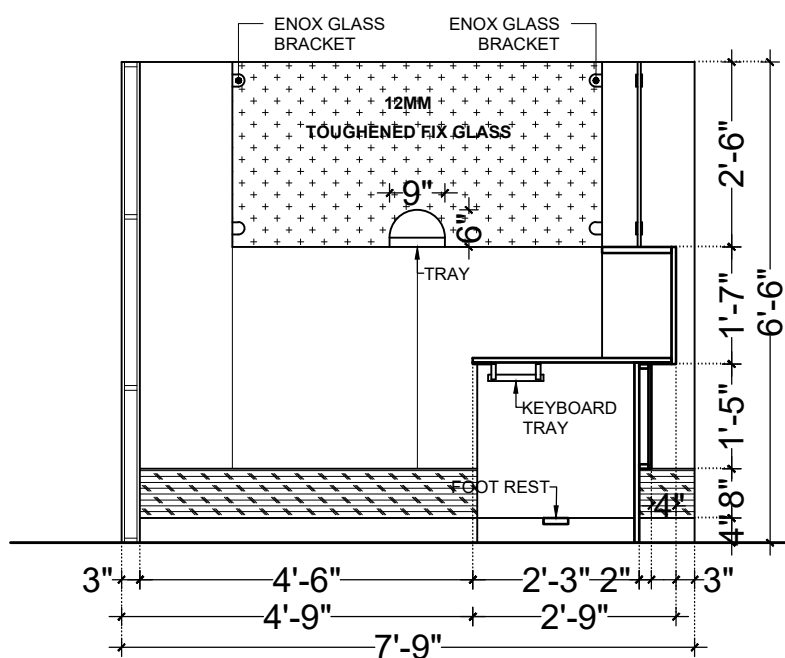

SECTION AA

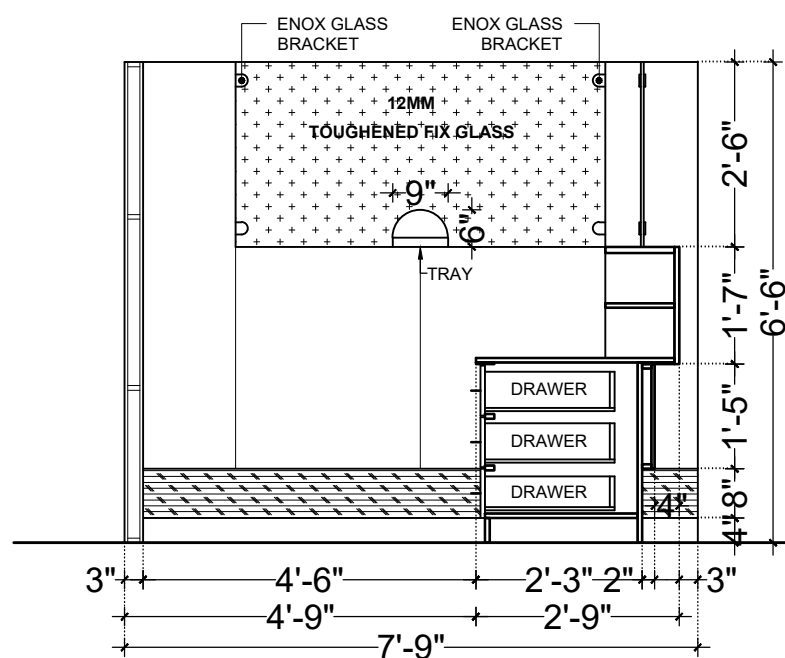

SECTION BB

CASH TABLE DETAIL (CT1-1)

NOTE :- CHECK DIMENSION AT SITE BEFORE EXECUTION

GROUND PLAN; INTERIOR LAY-OUT PLAN
of proposed bank building
for Bank of Baroda , UPLETA BRANCH
UPLETA.

Anil Vadgama
Architect
98241 67971

V n B Designs
Architecture & Interior

210, nakshatra II commercial complex, opp.k.k.v hall, 150 feet wide ring road,
rajkot- 360 005. e-mail : vnbdesigns@rediffmail.com.

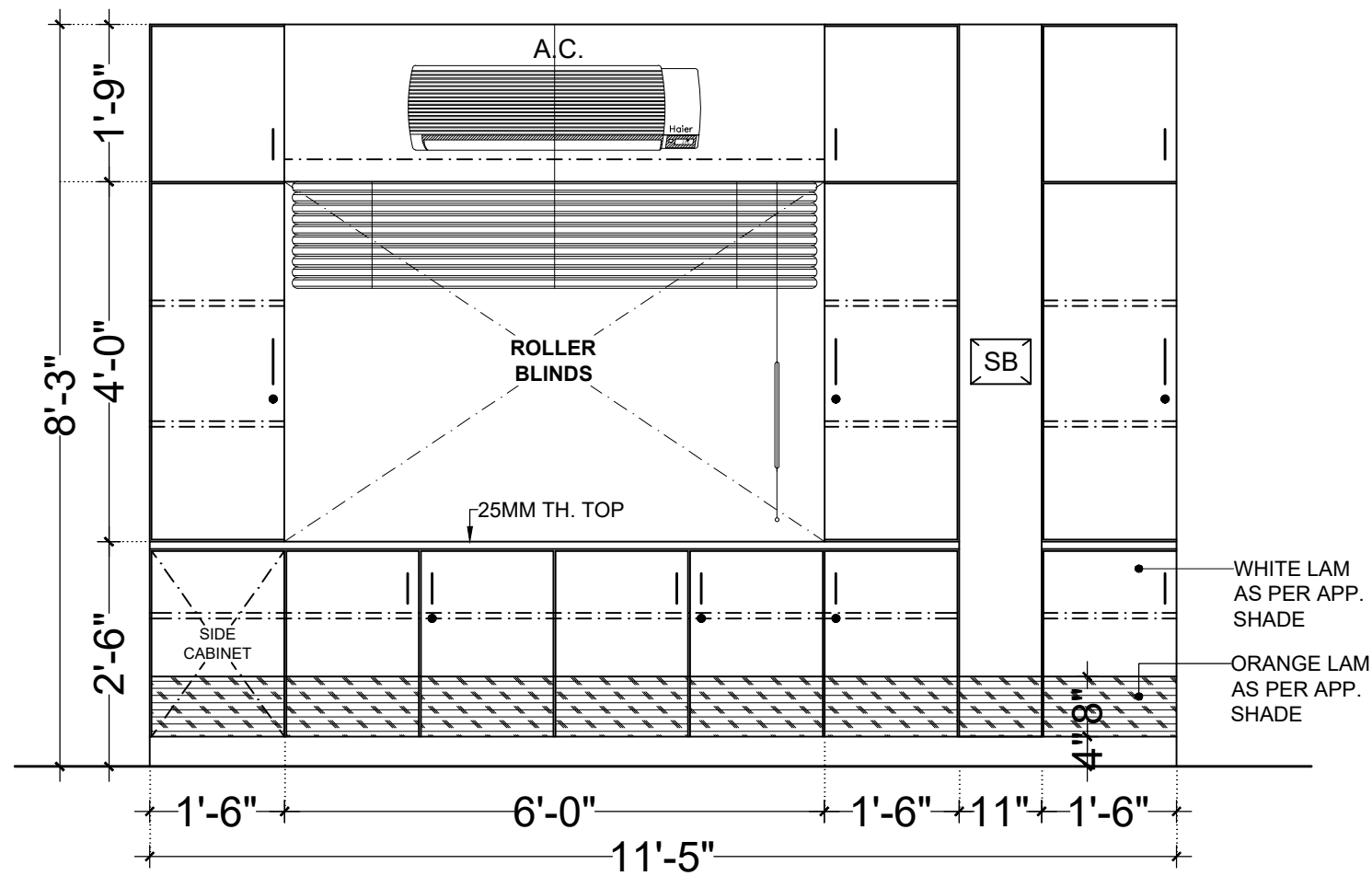

ELEVATION (CB1)

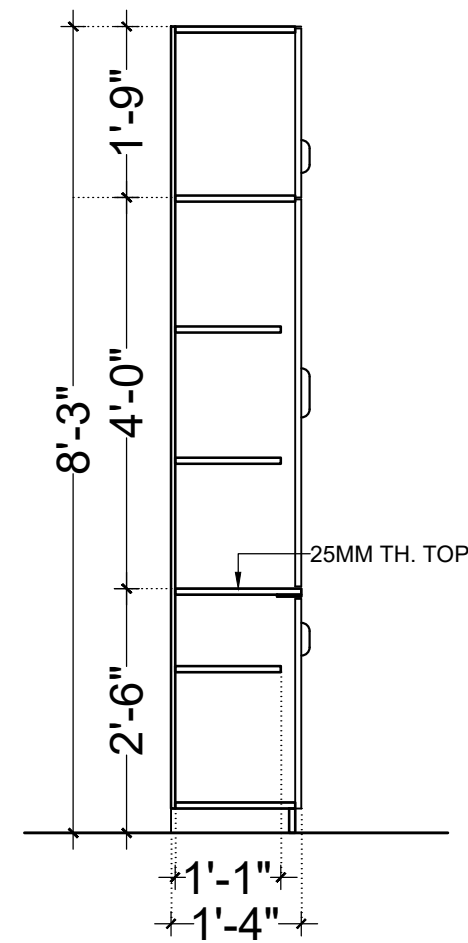

SECTION AA (CB1)

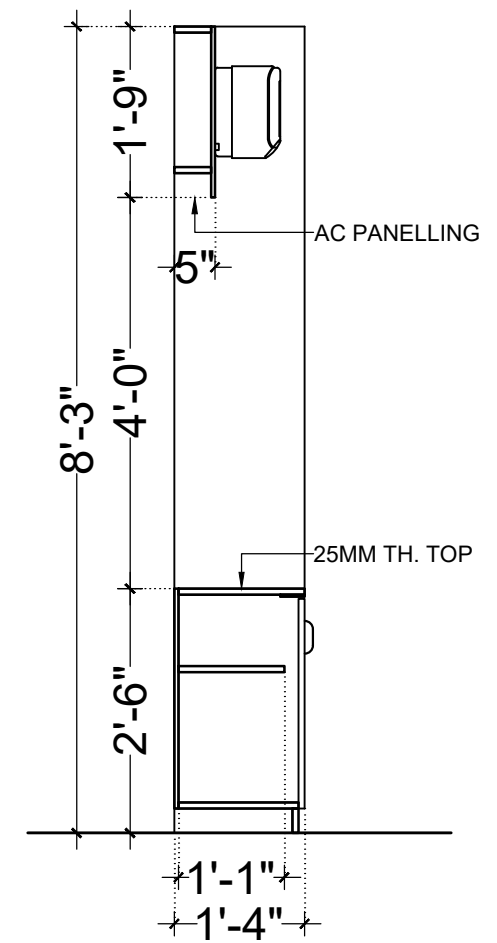

SECTION BB (CB1)

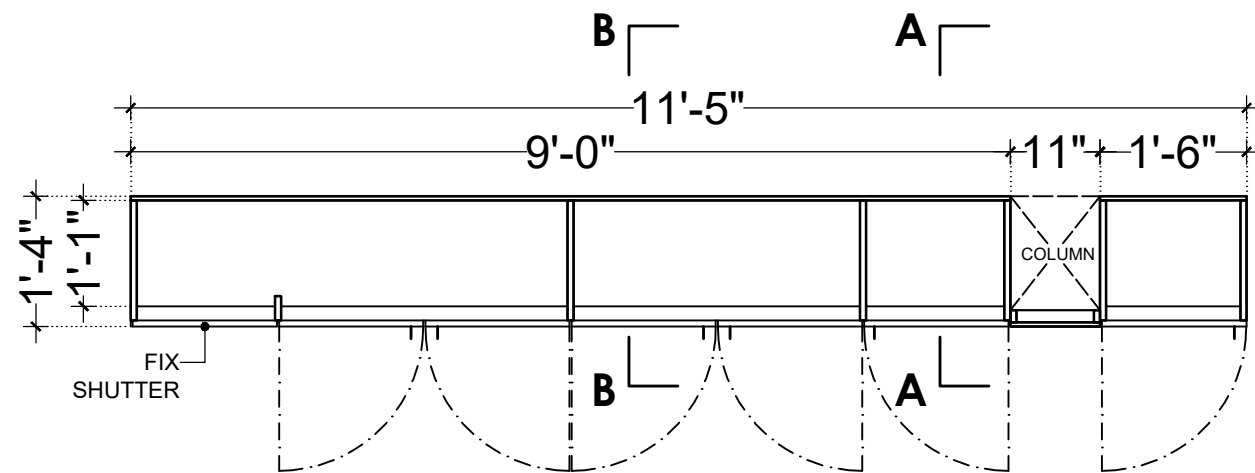

PLAN (CB1) (LVL + 2'-0")

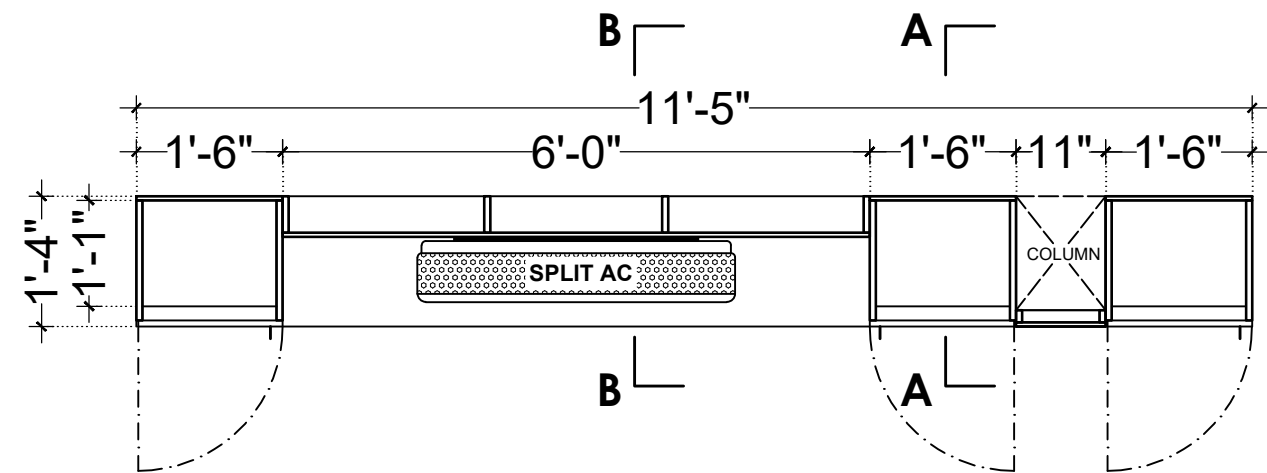

PLAN (CB1) (LVL + 7'-0")

OFFICER CUPBOARD DETAIL (CB1)

NOTE :- CHECK DIMENSION AT SITE BEFORE EXECUTION

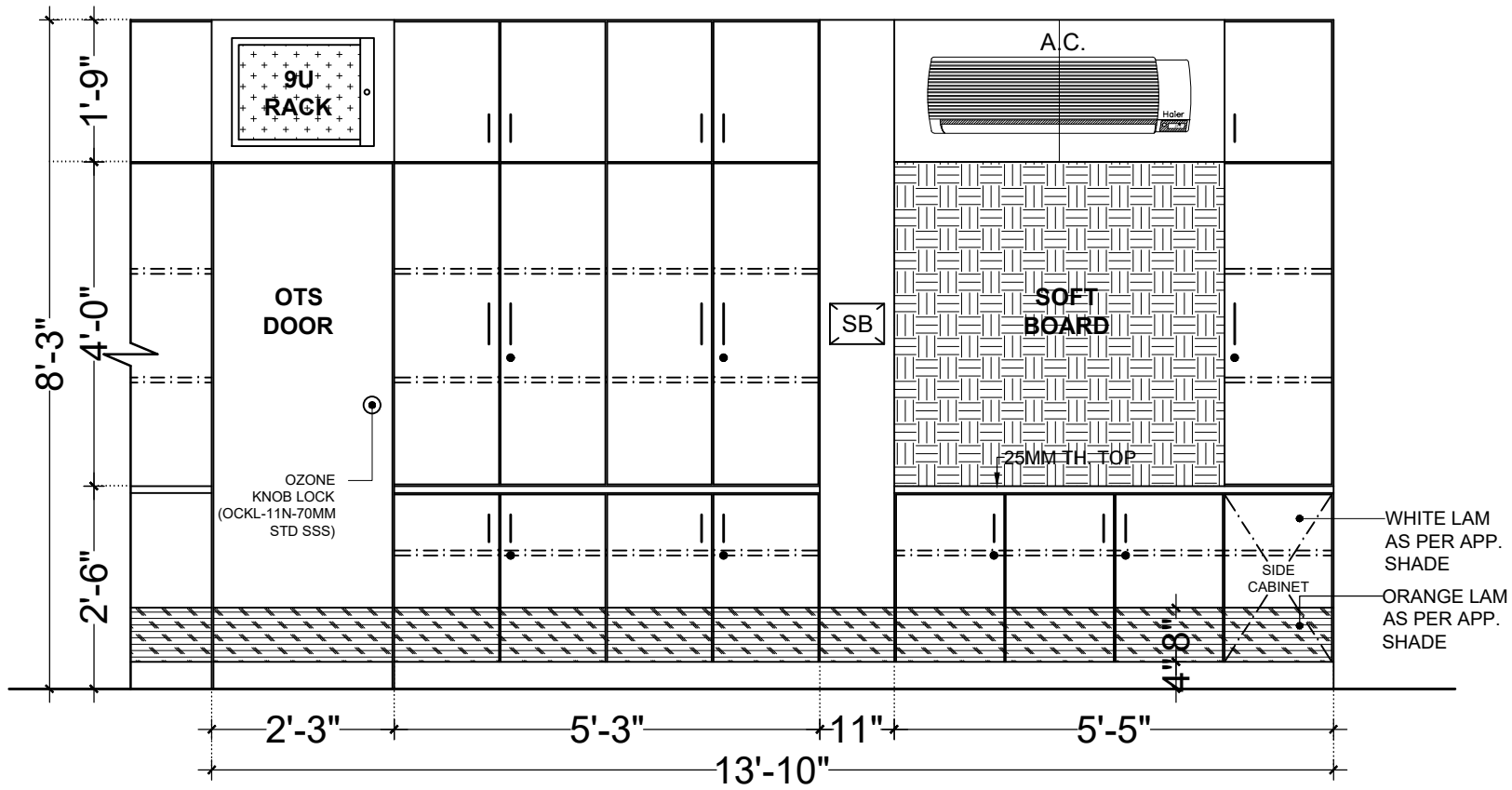

ELEVATION (CB2)

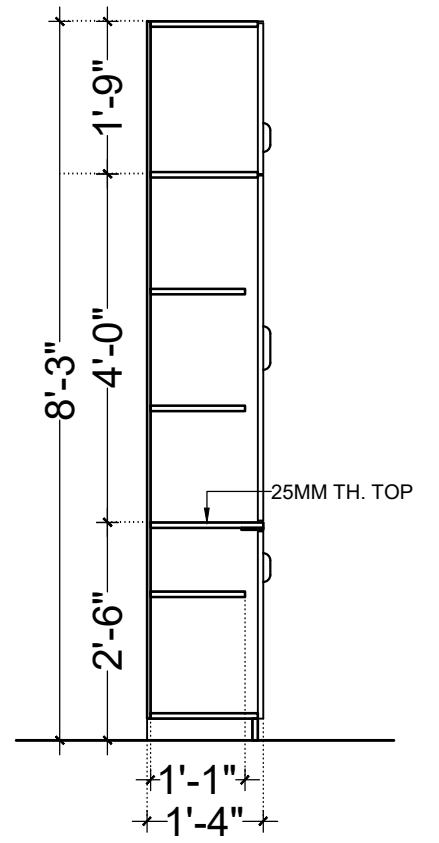

SECTION AA (CB2)

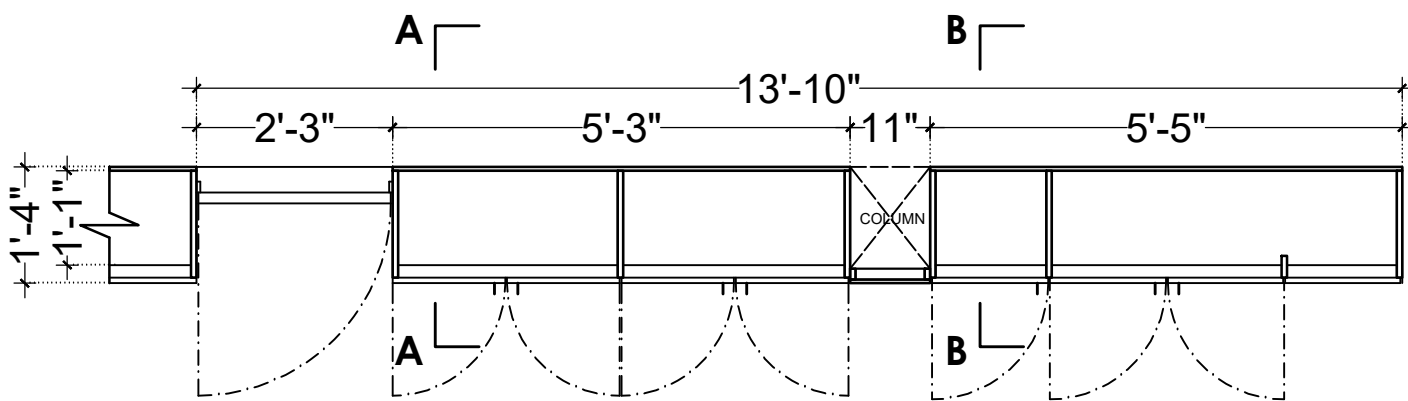

PLAN (CB2) (LVL + 2'-0")

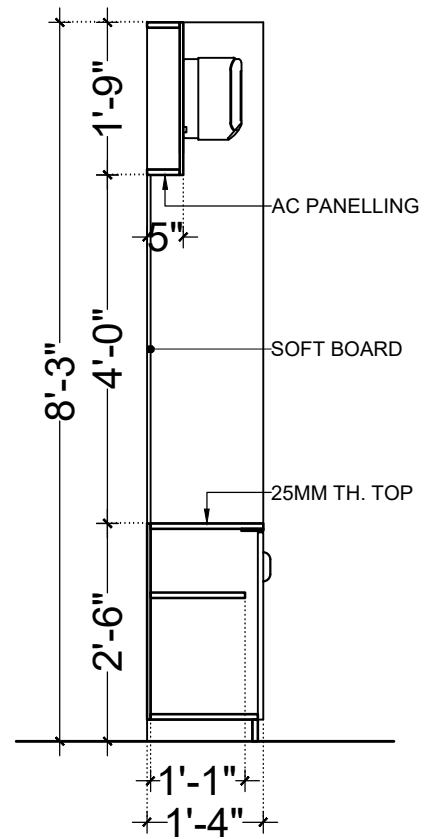

SECTION BB (CB2)

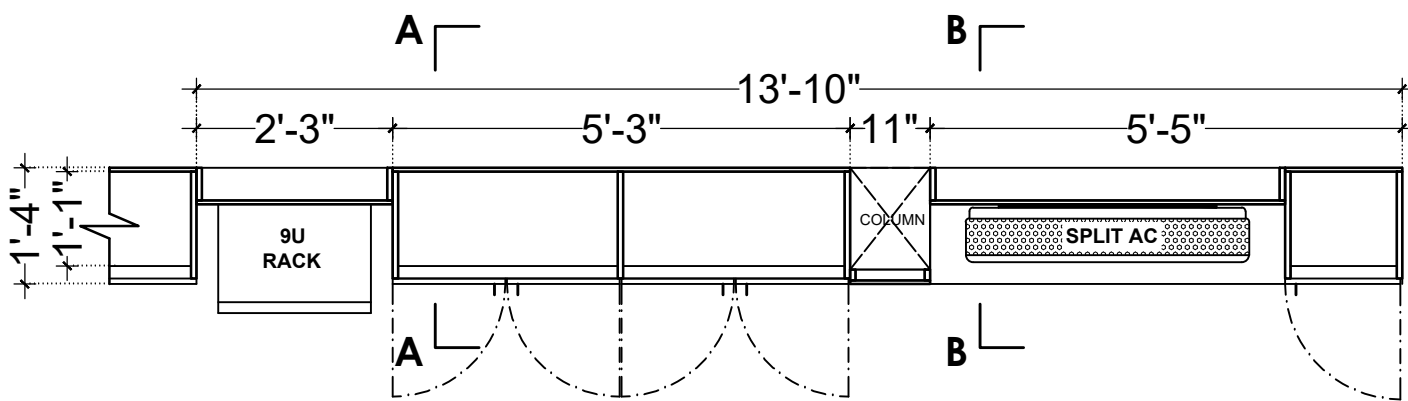

PLAN (CB2) (LVL + 7'-0")

OFFICER CUPBOARD DETAIL (CB2)

NOTE :- CHECK DIMENSION AT SITE BEFORE EXECUTION

GROUND PLAN; INTERIOR LAY-OUT PLAN
of proposed bank building
for Bank of Baroda , UPLETA BRANCH
UPLETA.

Anil Vadgama
Architect
98241 67971
V n B Designs
Architecture & Interior
210, nakshatra II commercial complex, opp.k.k.v hall, 150 feet wide ring road,
rajkot- 360 005. e-mail : vnbdesigns@rediffmail.com.

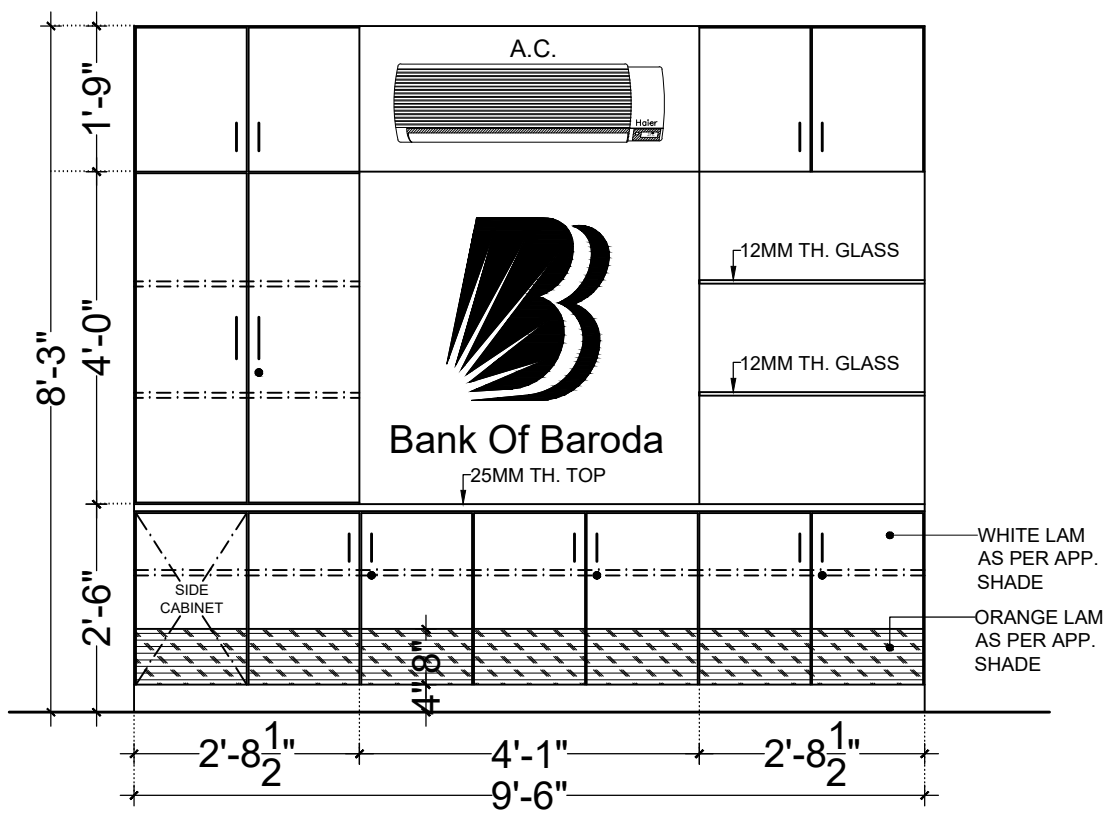

ELEVATION (CB3)

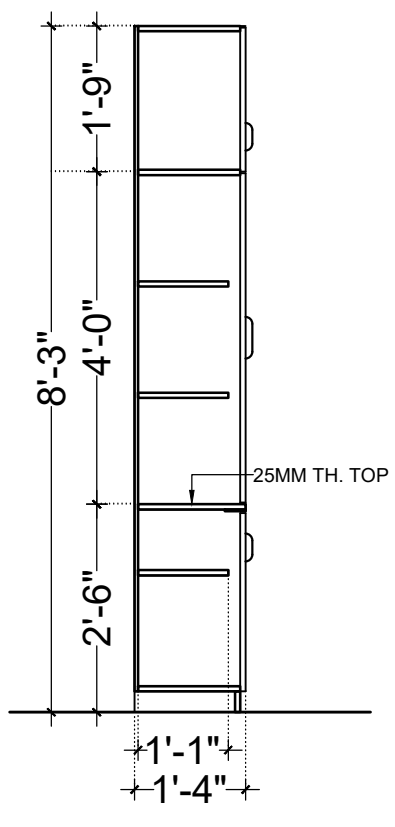

SECTION AA (CB3)

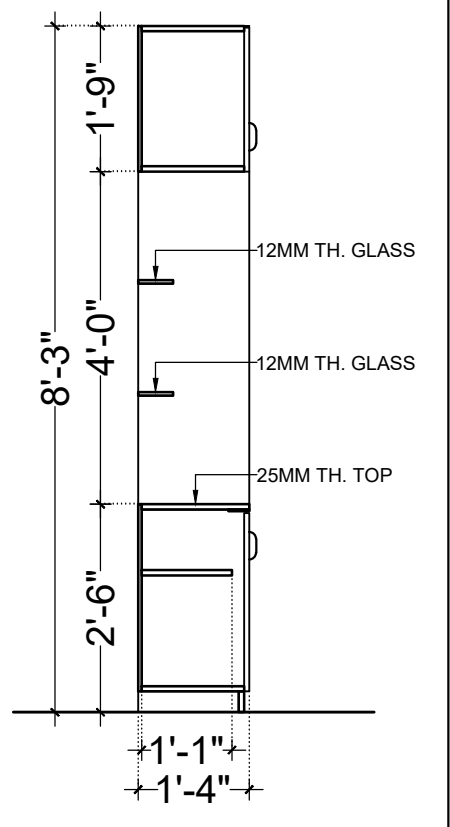

SECTION CC (CB3)

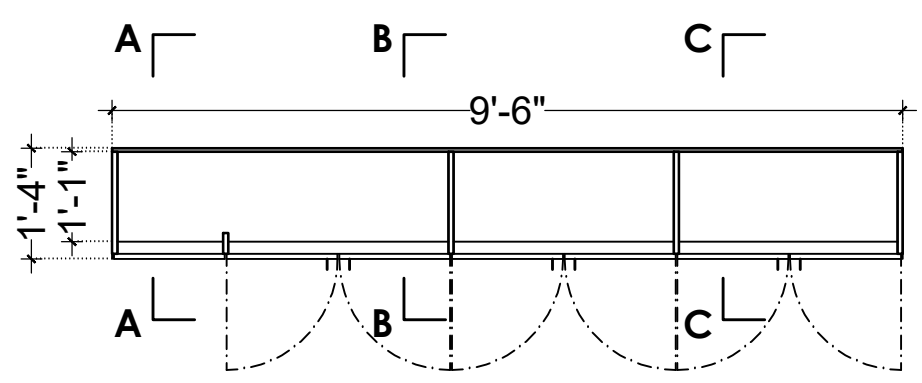

PLAN (CB3) (LVL + 2'-0")

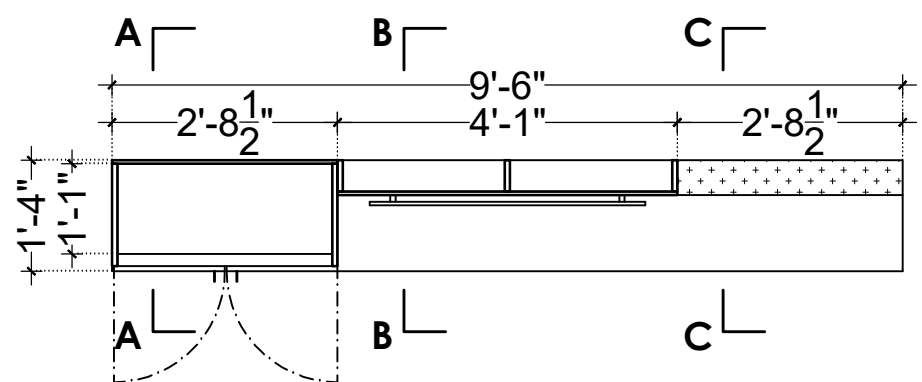

PLAN (CB3) (LVL + 5'-0")

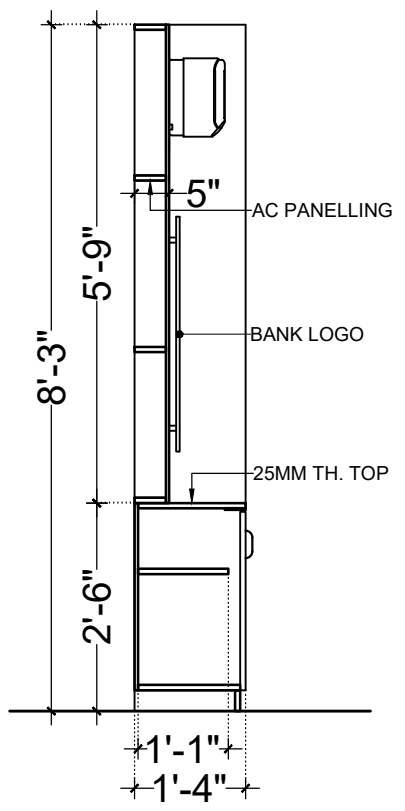

SECTION BB (CB3)

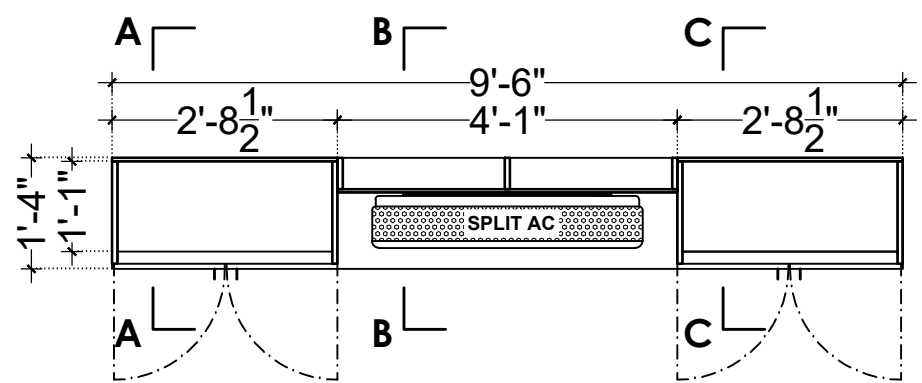

PLAN (CB3) (LVL + 7'-0")

MANAGER CUPBOARD DETAIL (CB3)

NOTE :- CHECK DIMENSION AT SITE BEFORE EXECUTION

GROUND PLAN; INTERIOR LAY-OUT PLAN
of proposed bank building
for Bank of Baroda , UPLETA BRANCH
UPLETA.

Anil Vadgama
Architect
98241 67971
V n B Designs
Architecture & Interior
210, nakshatra II commercial complex, opp.k.k.v hall, 150 feet wide ring road,
rajkot- 360 005. e-mail : vnbdesigns@rediffmail.com.

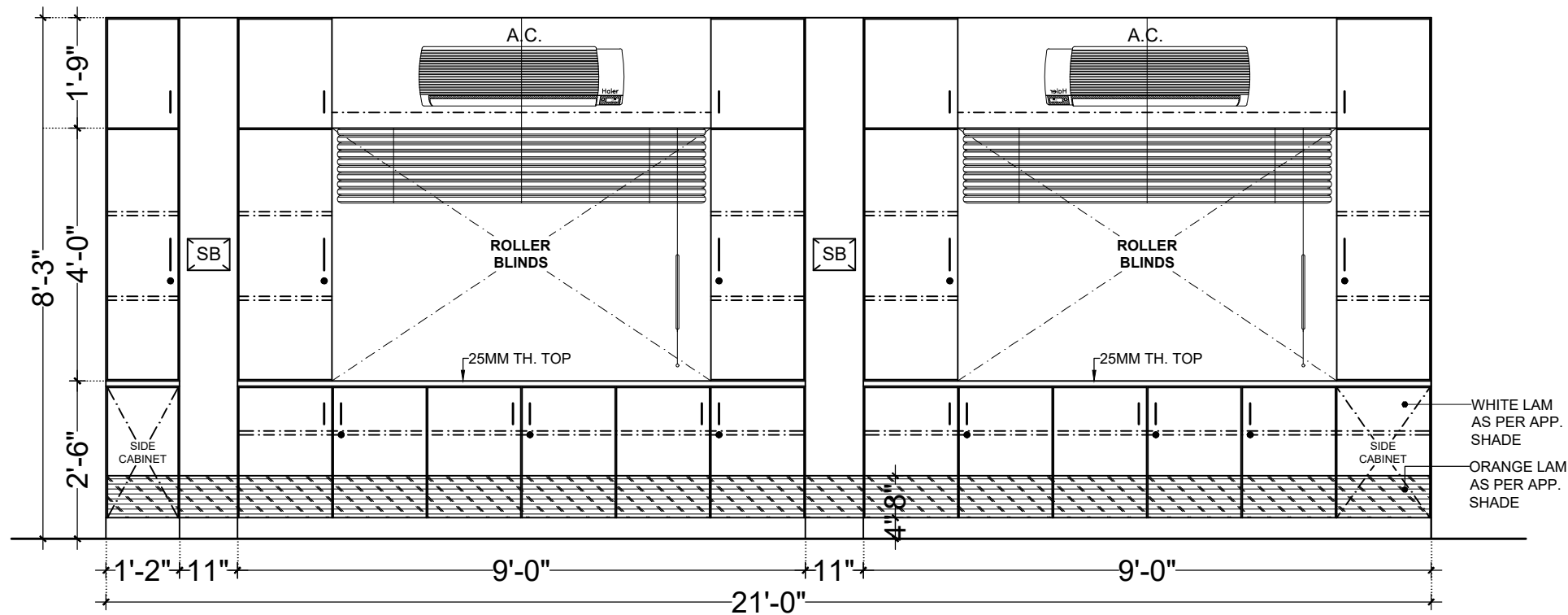

ELEVATION (CB4)

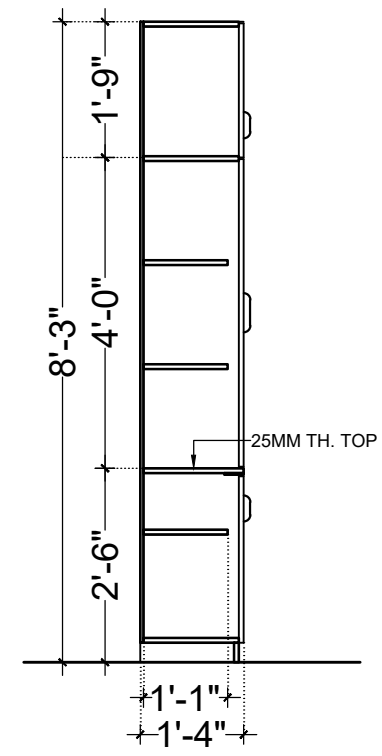

SECTION AA (CB4)

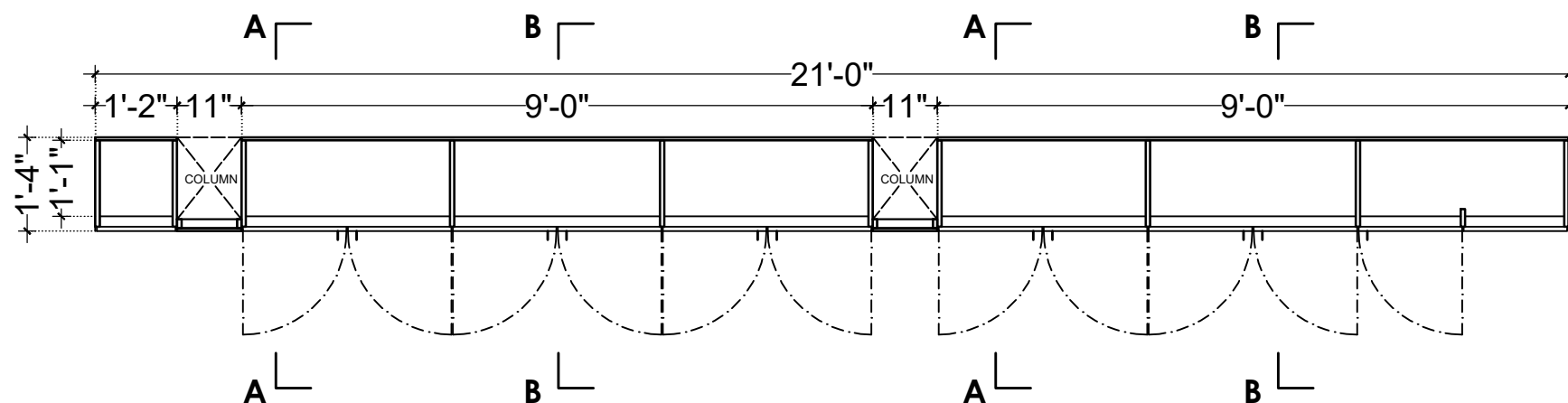

PLAN (CB4) (LVL + 2'-0")

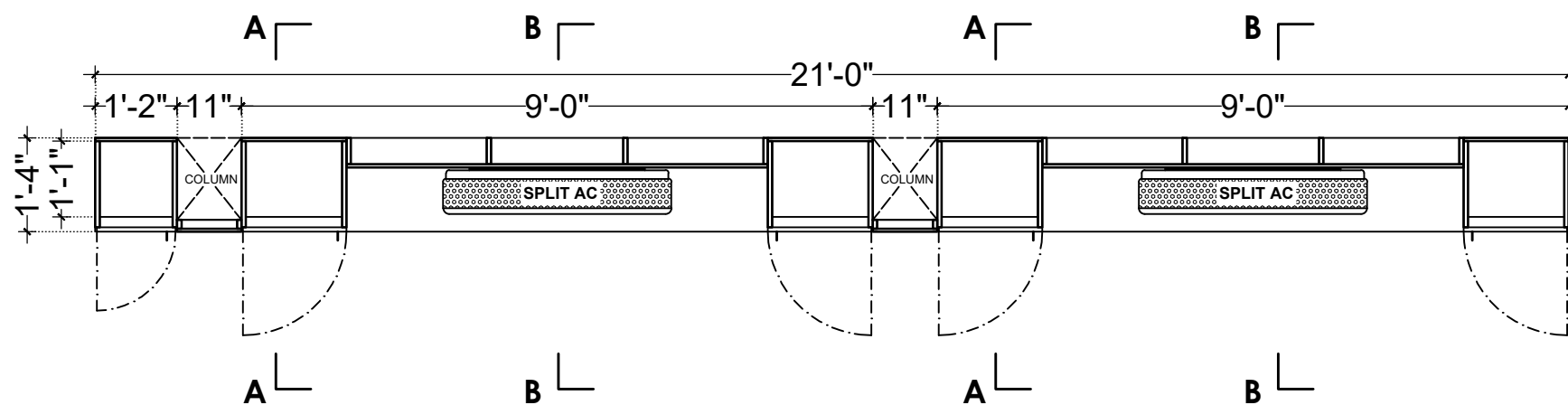

PLAN (CB4) (LVL + 7'-0")

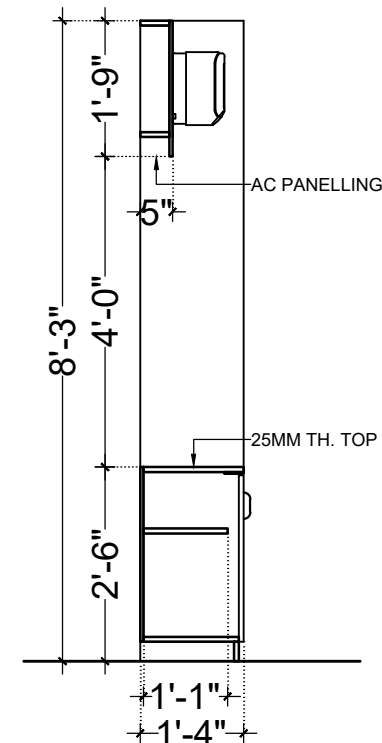

SECTION BB (CB4)

OFFICER CUPBOARD DETAIL (CB4)

NOTE :- CHECK DIMENSION AT SITE BEFORE EXECUTION

Anil Vadgama
Architect
98241 67971
V n B Designs
Architecture & Interior
210, Nakshatra II commercial complex, opp.k.v.hall,150 feet wide ring road,
rajkot-360 005.
e-mail : vnbdesigns@rediffmail.com.

GROUND PLAN; INTERIOR LAY-OUT PLAN
of proposed bank building
for Bank of Baroda , UPLETA BRANCH
UPLETA.

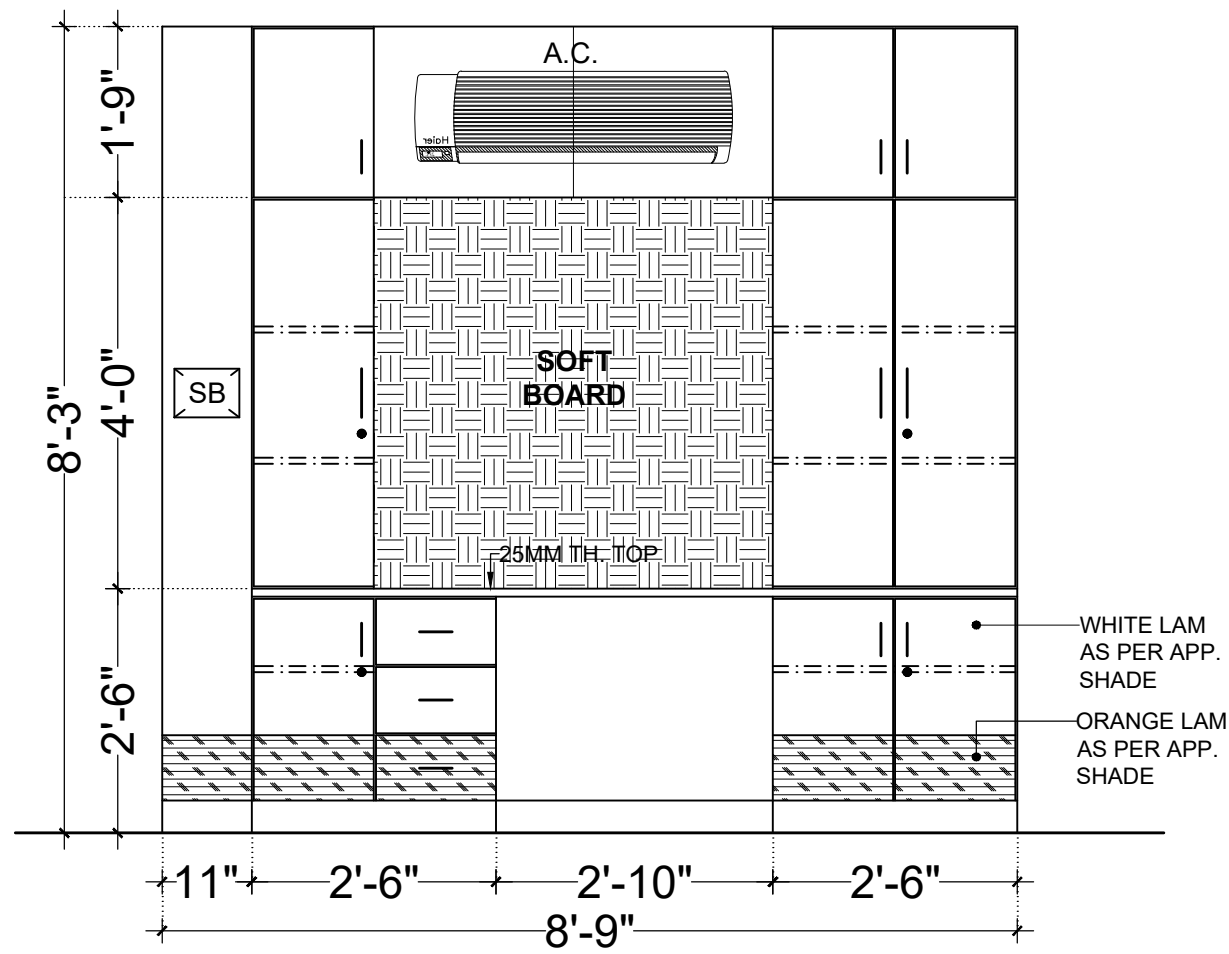

ELEVATION (CB5)

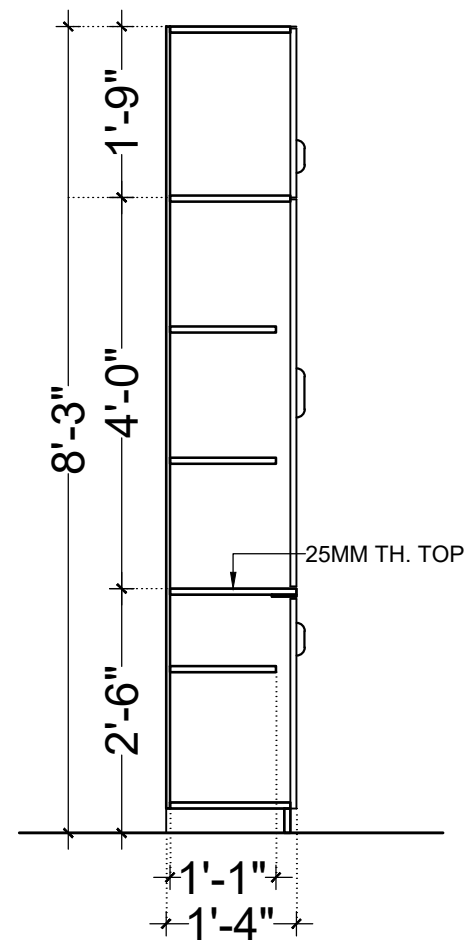

SECTION AA (CB5)

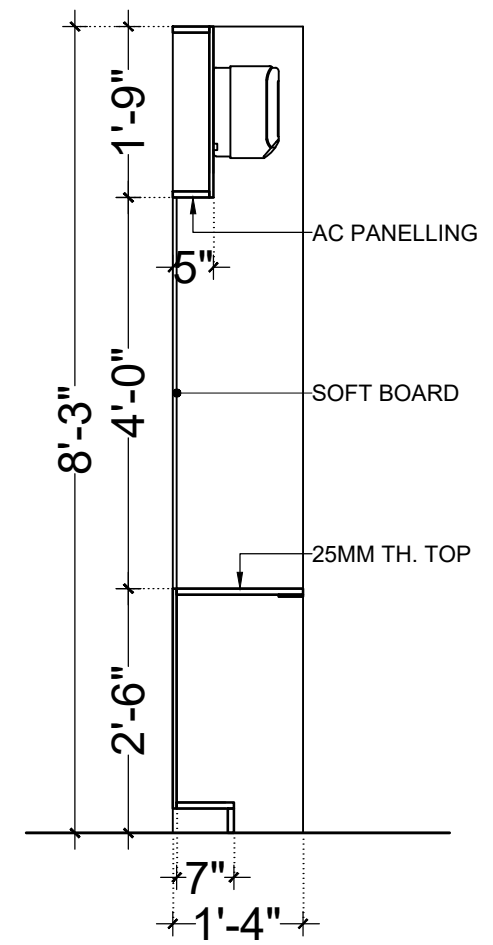

SECTION BB (CB5)

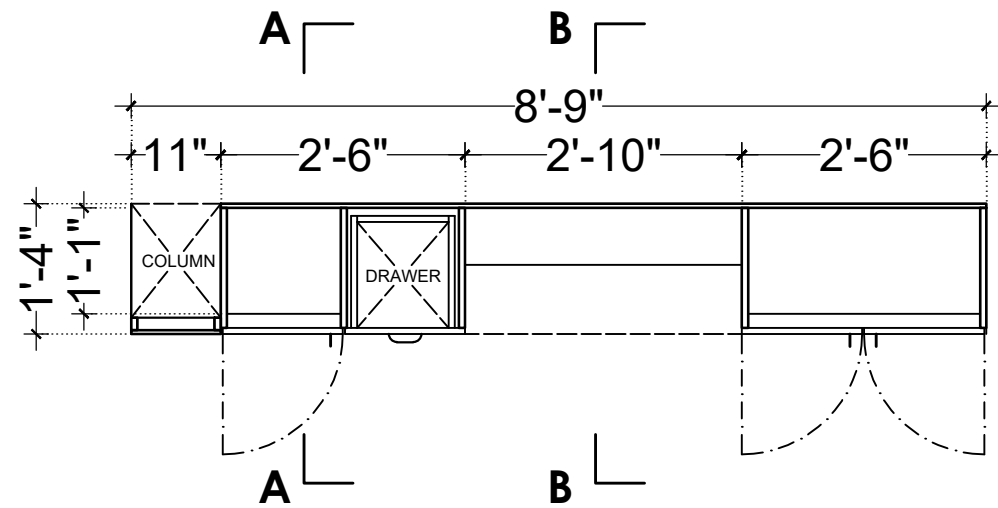

PLAN (CB5) (LVL + 2'-0")

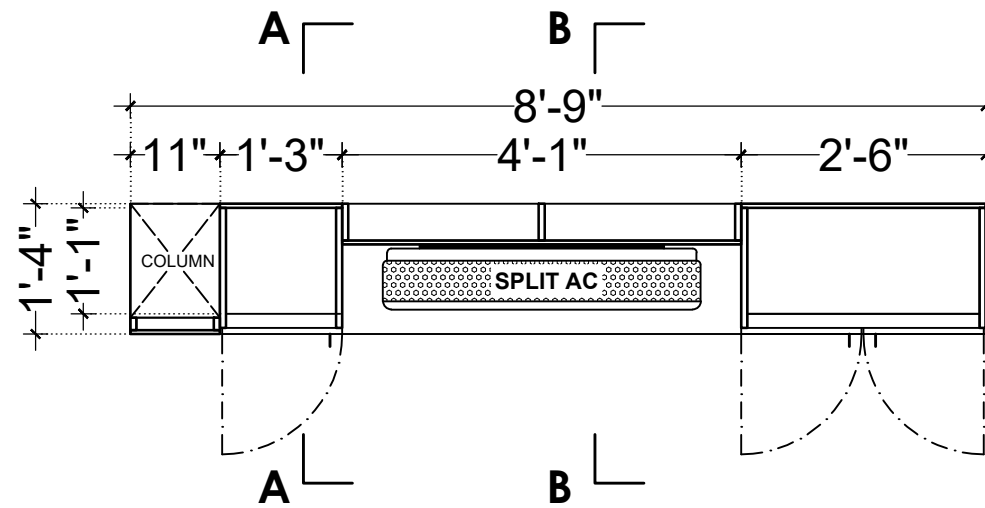

PLAN (CB5) (LVL + 7'-0")

CASH CUPBOARD DETAIL (CB5)

NOTE :- CHECK DIMENSION AT SITE BEFORE EXECUTION

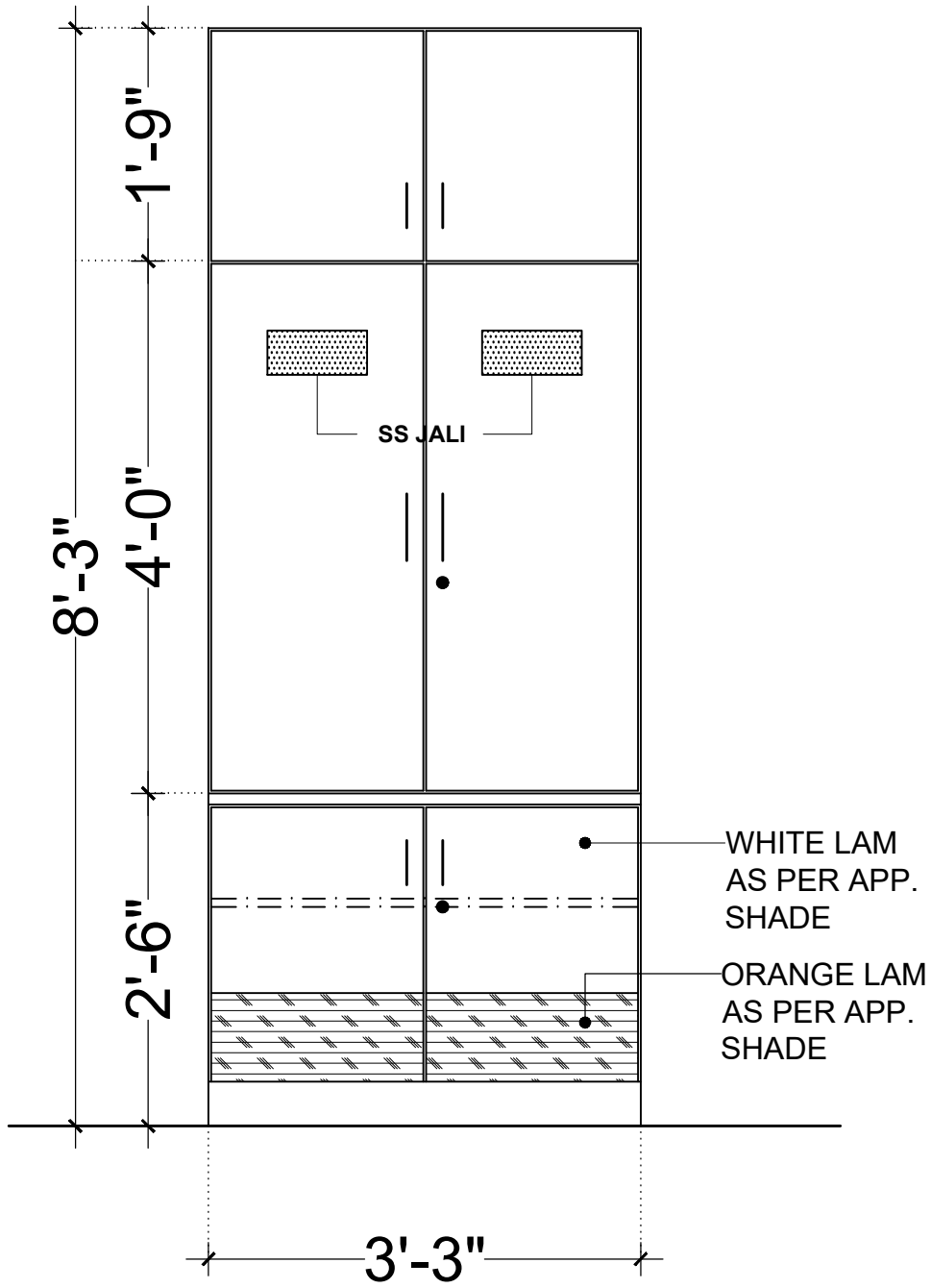

ELEVATION (CB6)

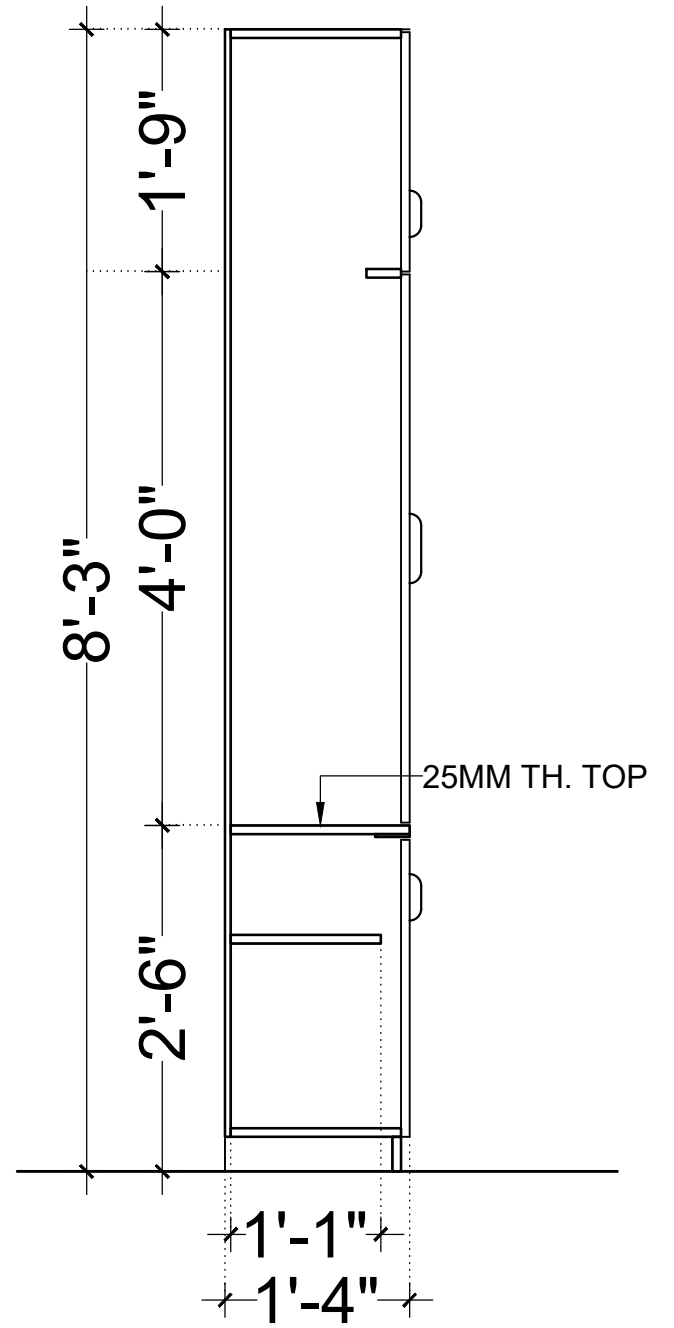

SECTION AA (CB6)

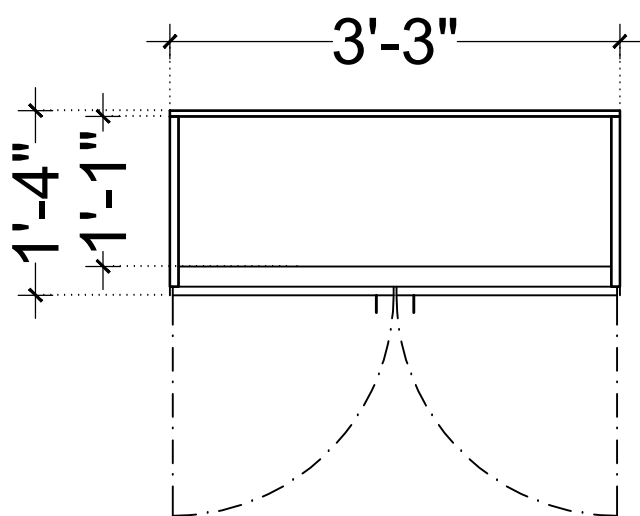

PLAN (CB6) (LVL + 2'-0")

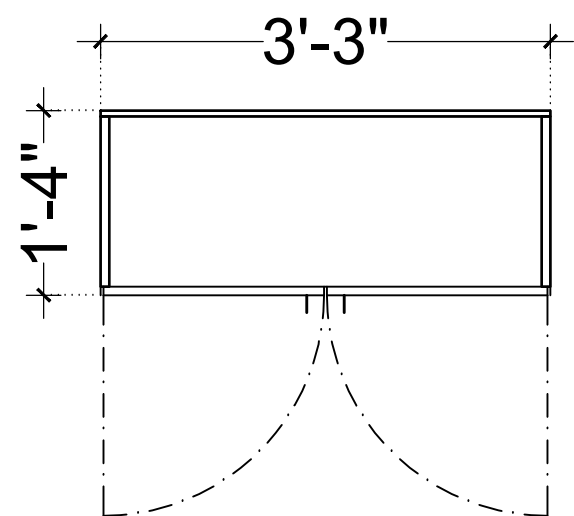

PLAN (CB6) (LVL + 5'-0")

ELECTRIC CUPBOARD DETAIL (CB6)

NOTE :- CHECK DIMENSION AT SITE BEFORE EXECUTION

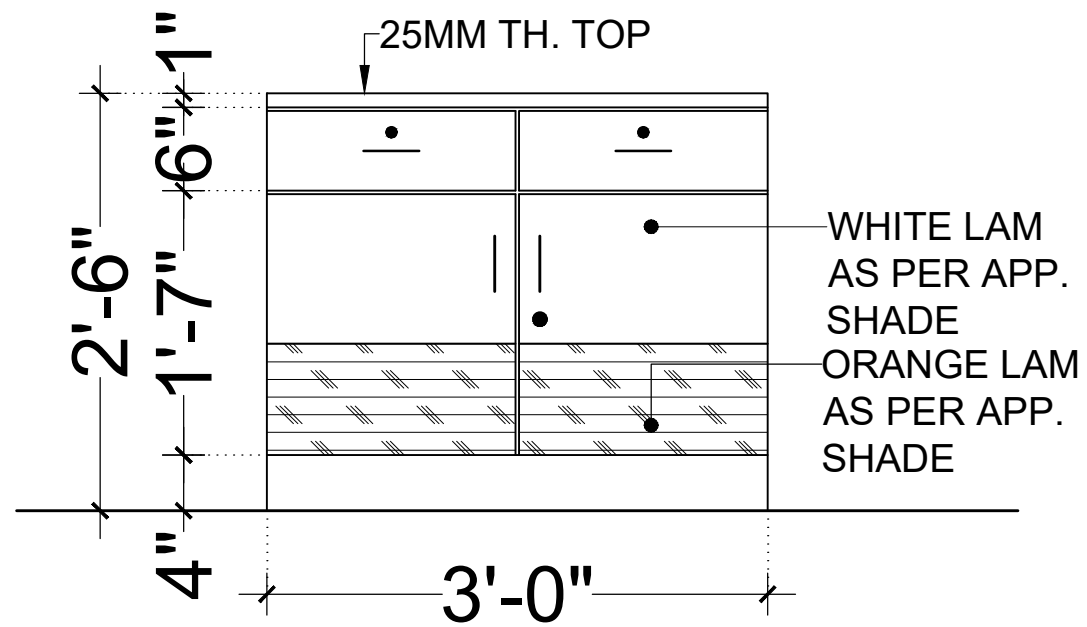

ELEVATION (FRONT) (SC1)

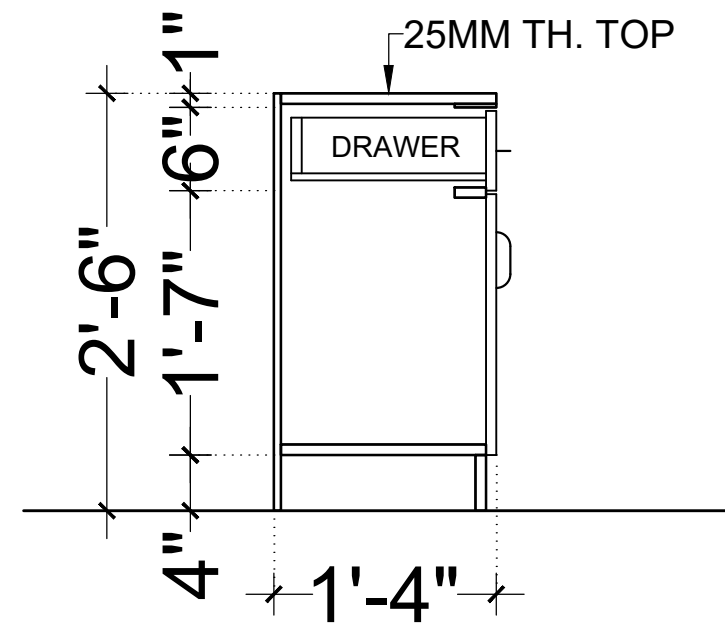

SECTION AA (SC1)

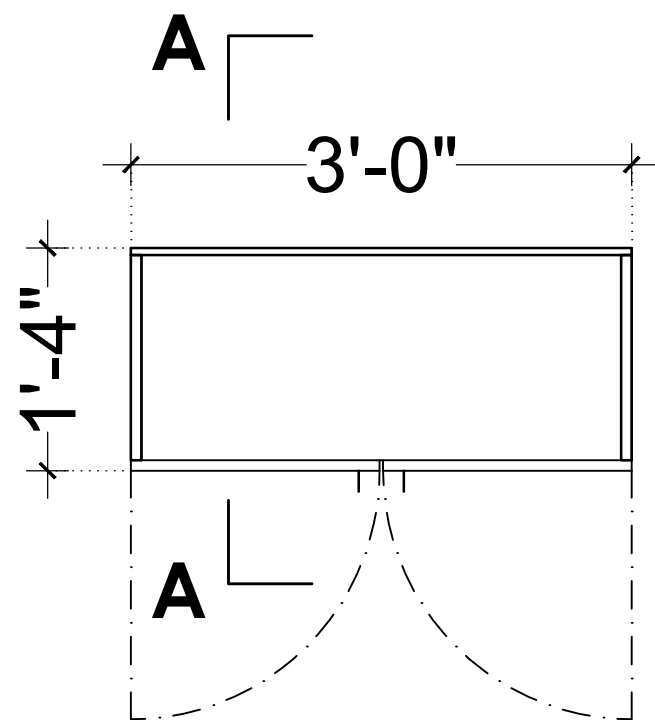

PLAN (LVL + 1'-6") (SC1)

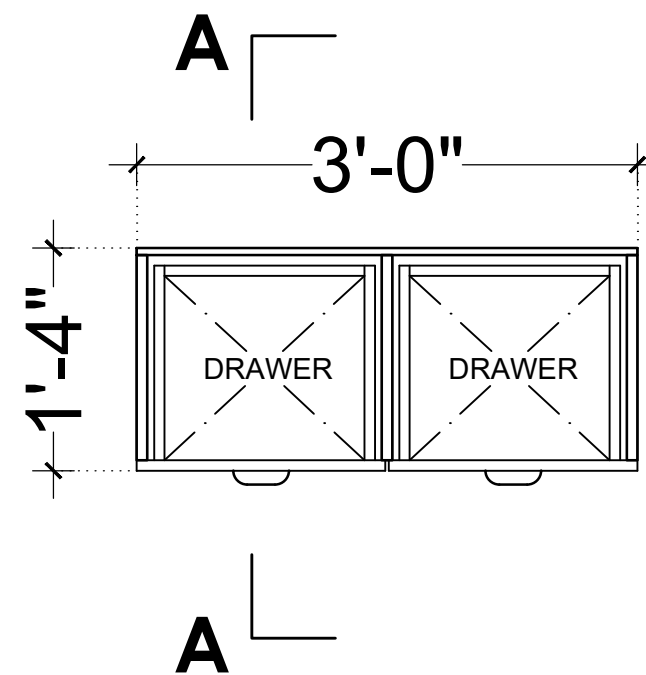

PLAN (LVL + 2'-3") (SC1)

SIDE CABINET DETAIL (SC1)

NOTE :- CHECK DIMENSION AT SITE BEFORE EXECUTION

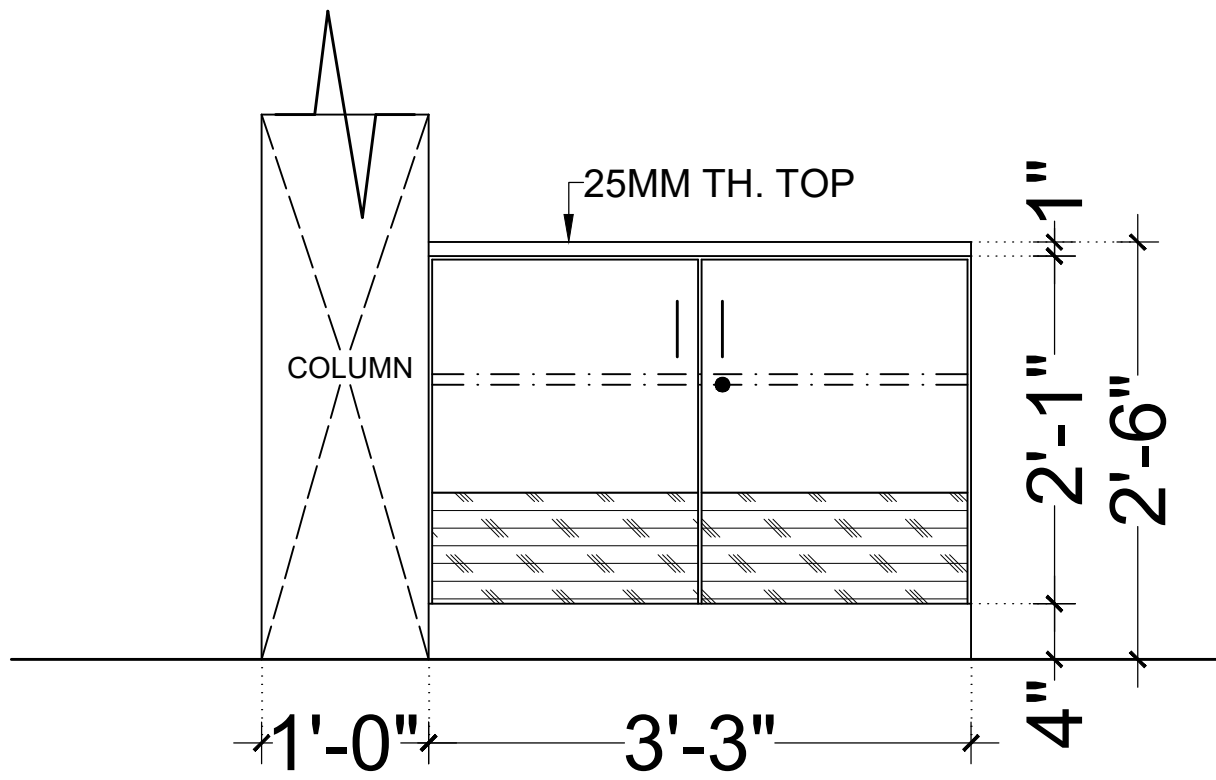

ELEVATION (FRONT) (SC2)

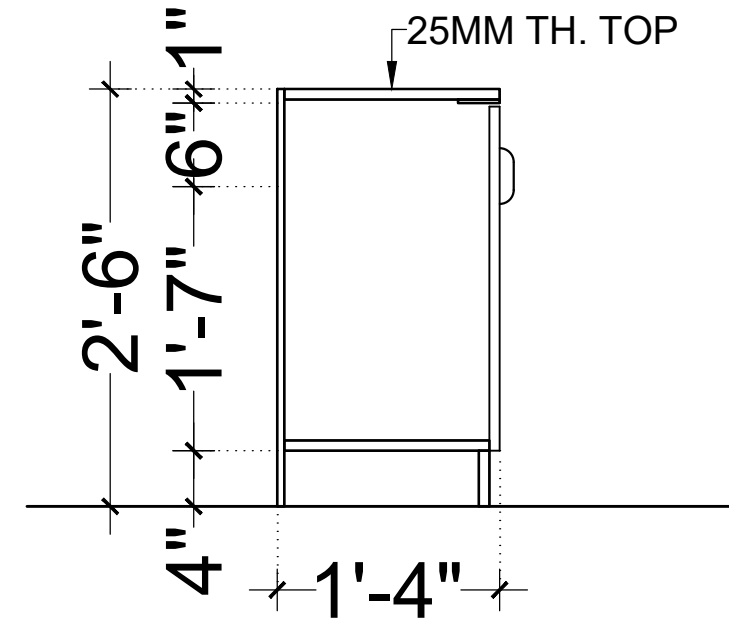

SECTION AA (SC2)

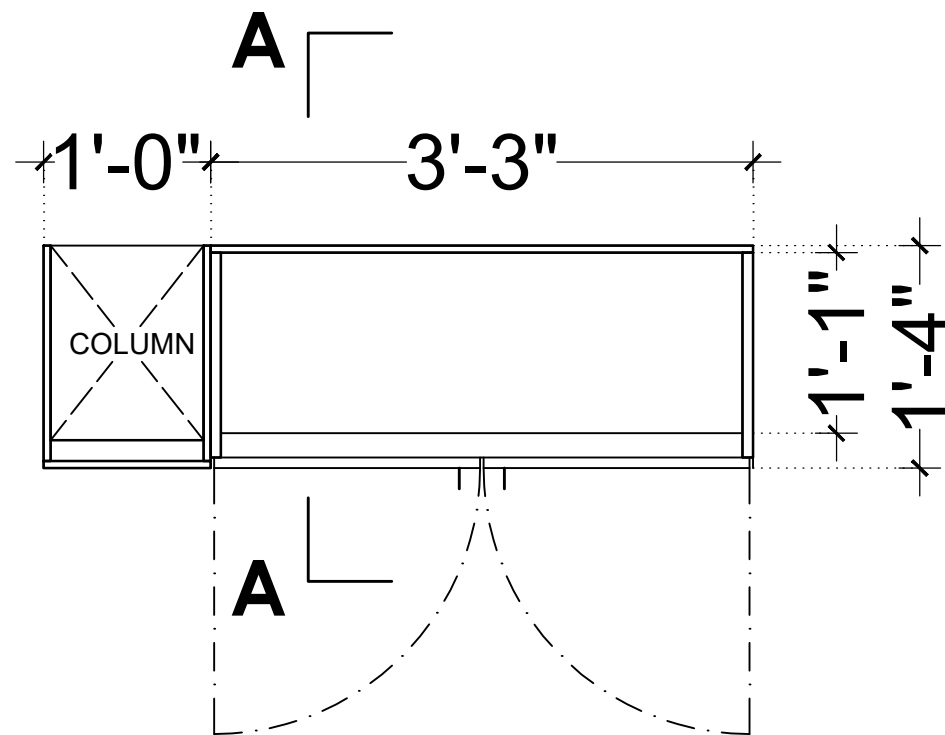

PLAN (LVL + 1'-6") (SC2)

SIDE CABINET DETAIL (SC2)

NOTE :- CHECK DIMENSION AT SITE BEFORE EXECUTION

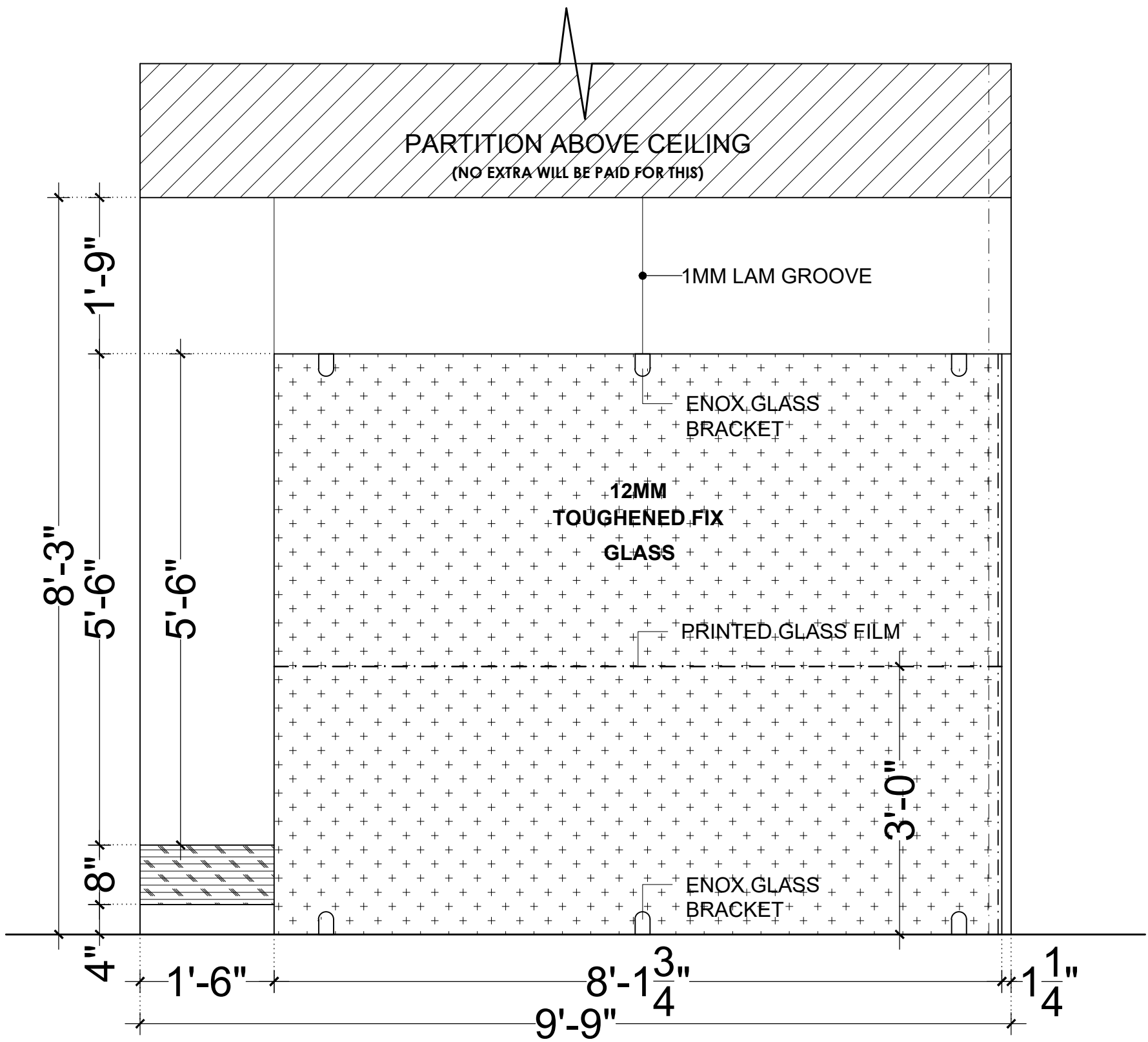

ELEVATION (PT1)

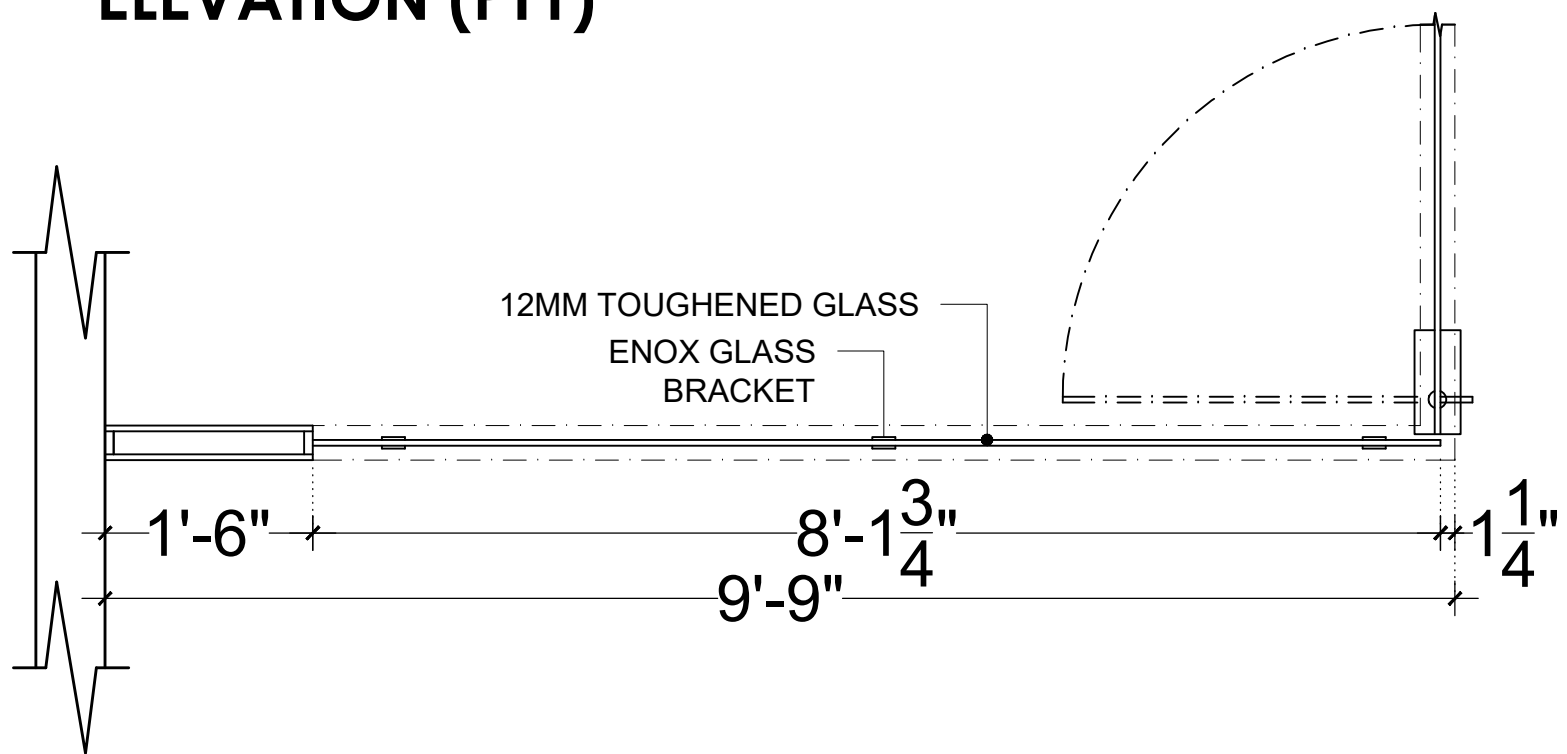

PLAN (PT1)

MANAGER CHAMBER PARTITION DETAIL (PT1)

NOTE :- CHECK DIMENSION AT SITE BEFORE EXECUTION

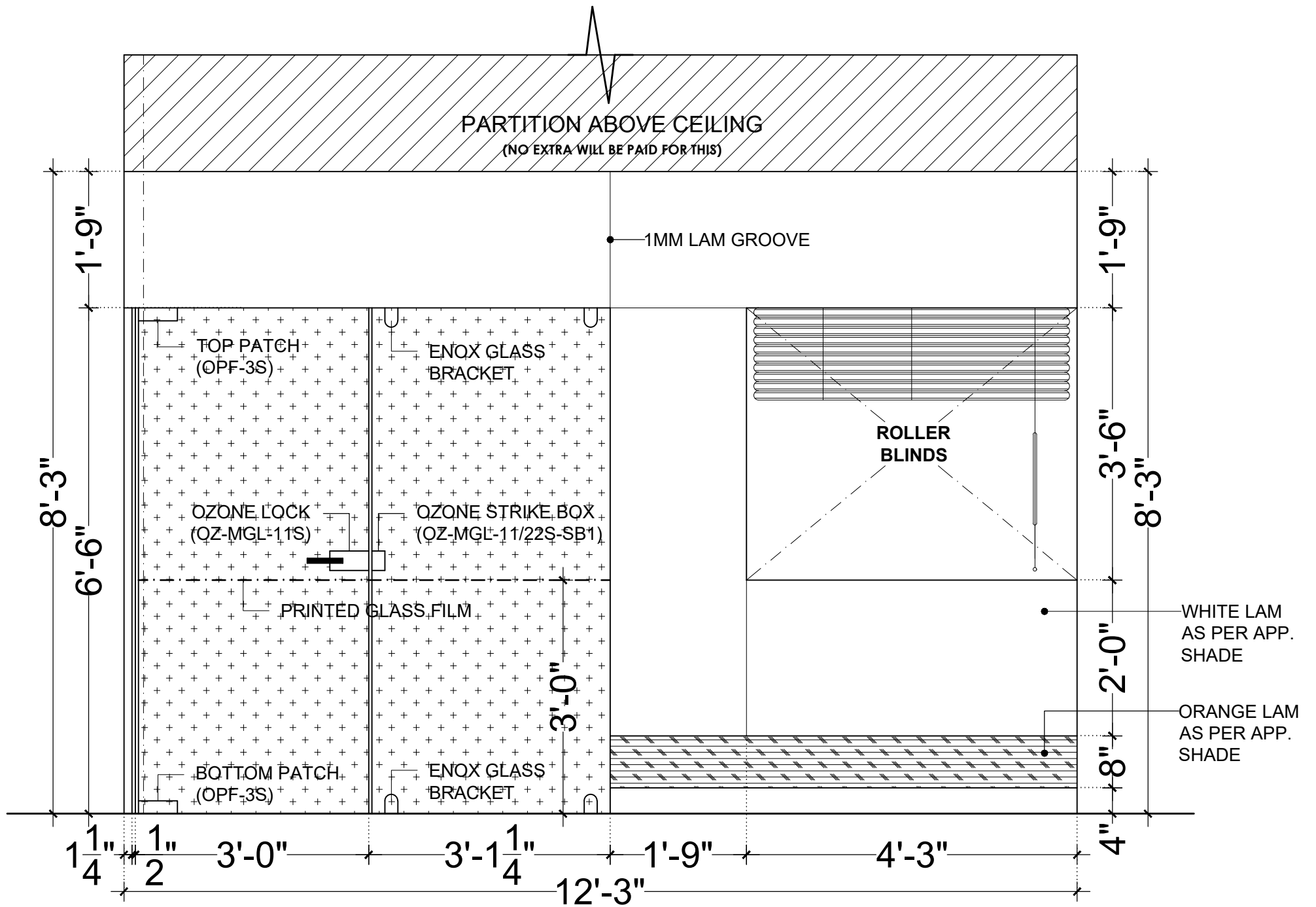

ELEVATION (PT2)

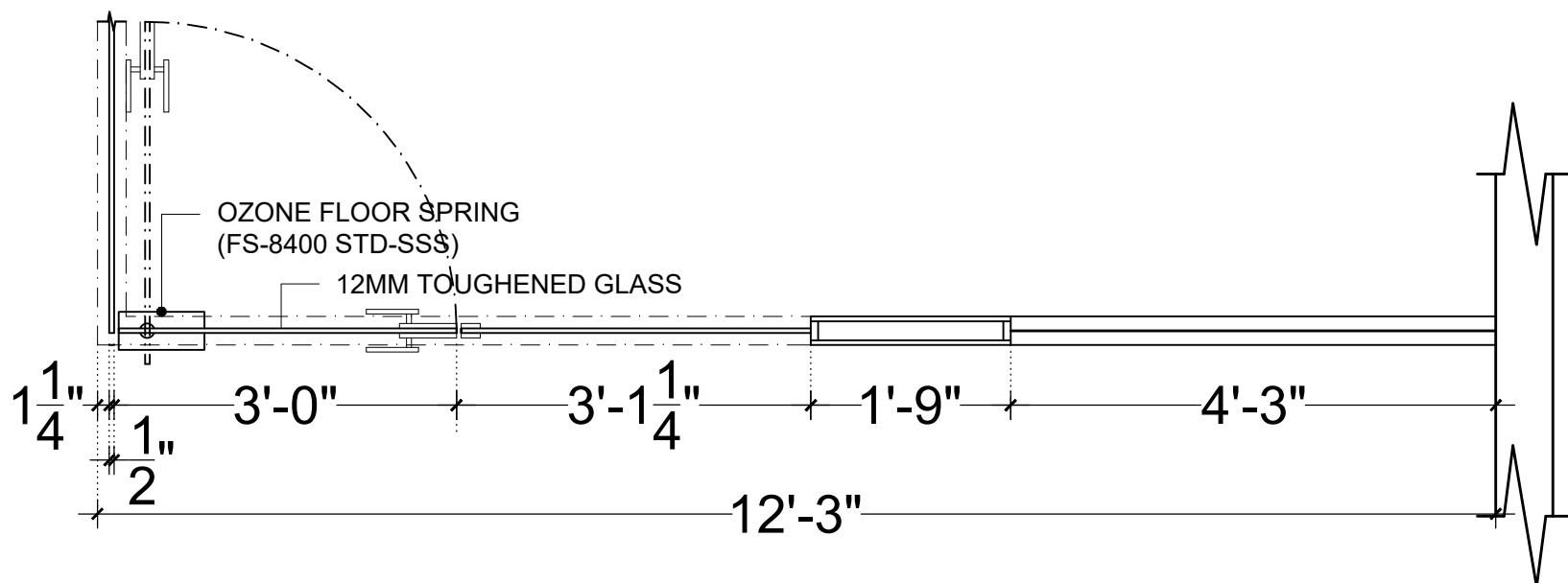

PLAN (PT2)

MANAGER CHAMBER PARTITION DETAIL (PT2)

NOTE :- CHECK DIMENSION AT SITE BEFORE EXECUTION

GROUND PLAN; INTERIOR LAY-OUT PLAN
of proposed bank building
for Bank of Baroda , UPLETA BRANCH
UPLETA.

Anil Vadgama
Architect
98241 67971
V n B Designs
Architecture & Interior
210, nakshatra II commercial complex, opp.k.k.v hall, 150 feet wide ring road,
rajkot- 360 005. e-mail : vnbdesigns@rediffmail.com.

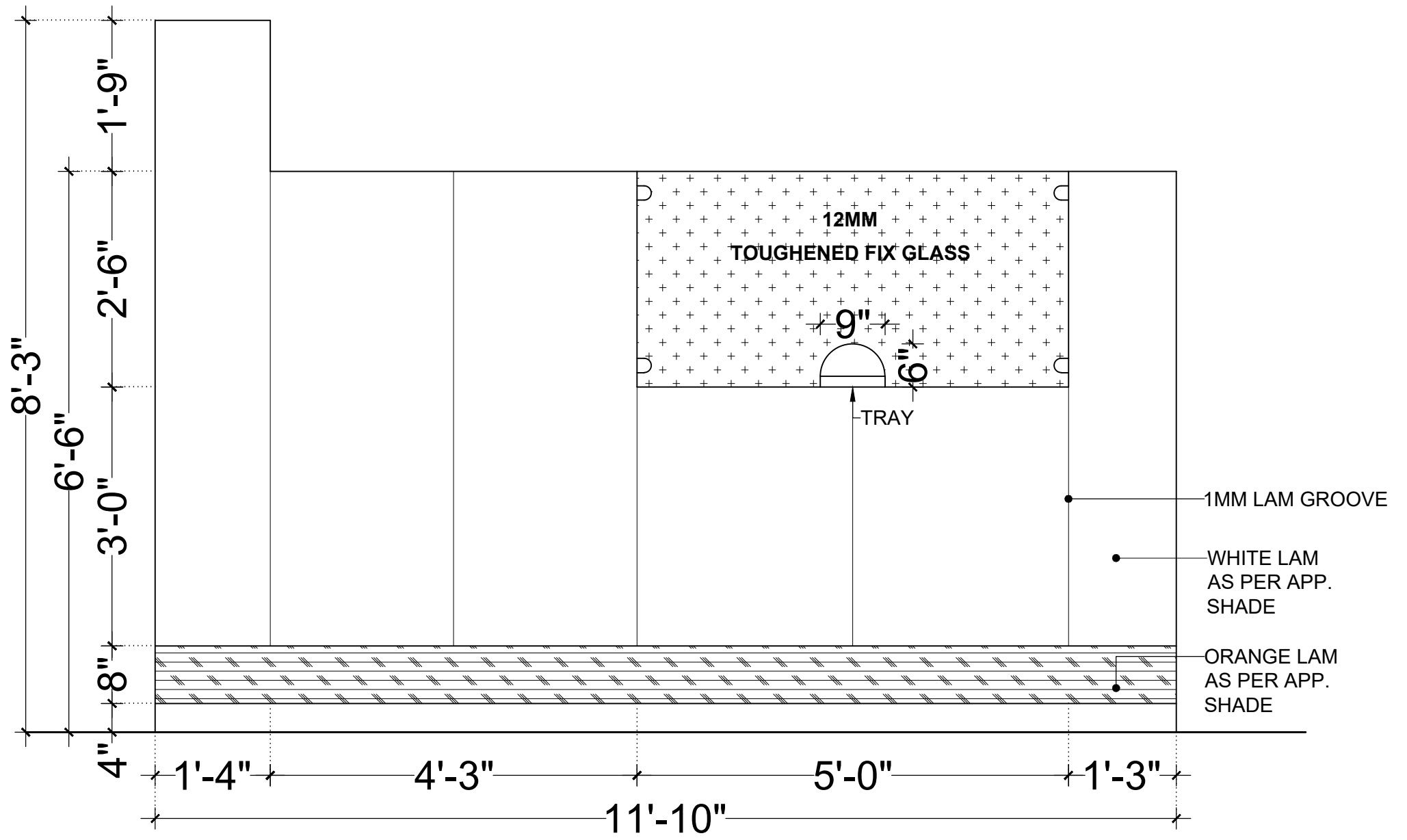

ELEVATION (PT3)

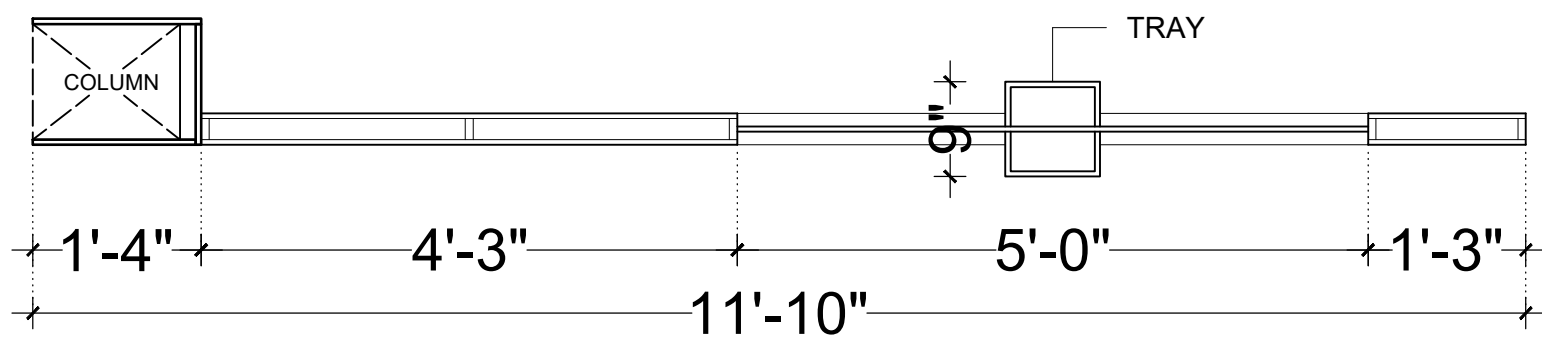

PLAN (PT3)

CASH PARTITION DETAIL (PT3)

NOTE :- CHECK DIMENSION AT SITE BEFORE EXECUTION

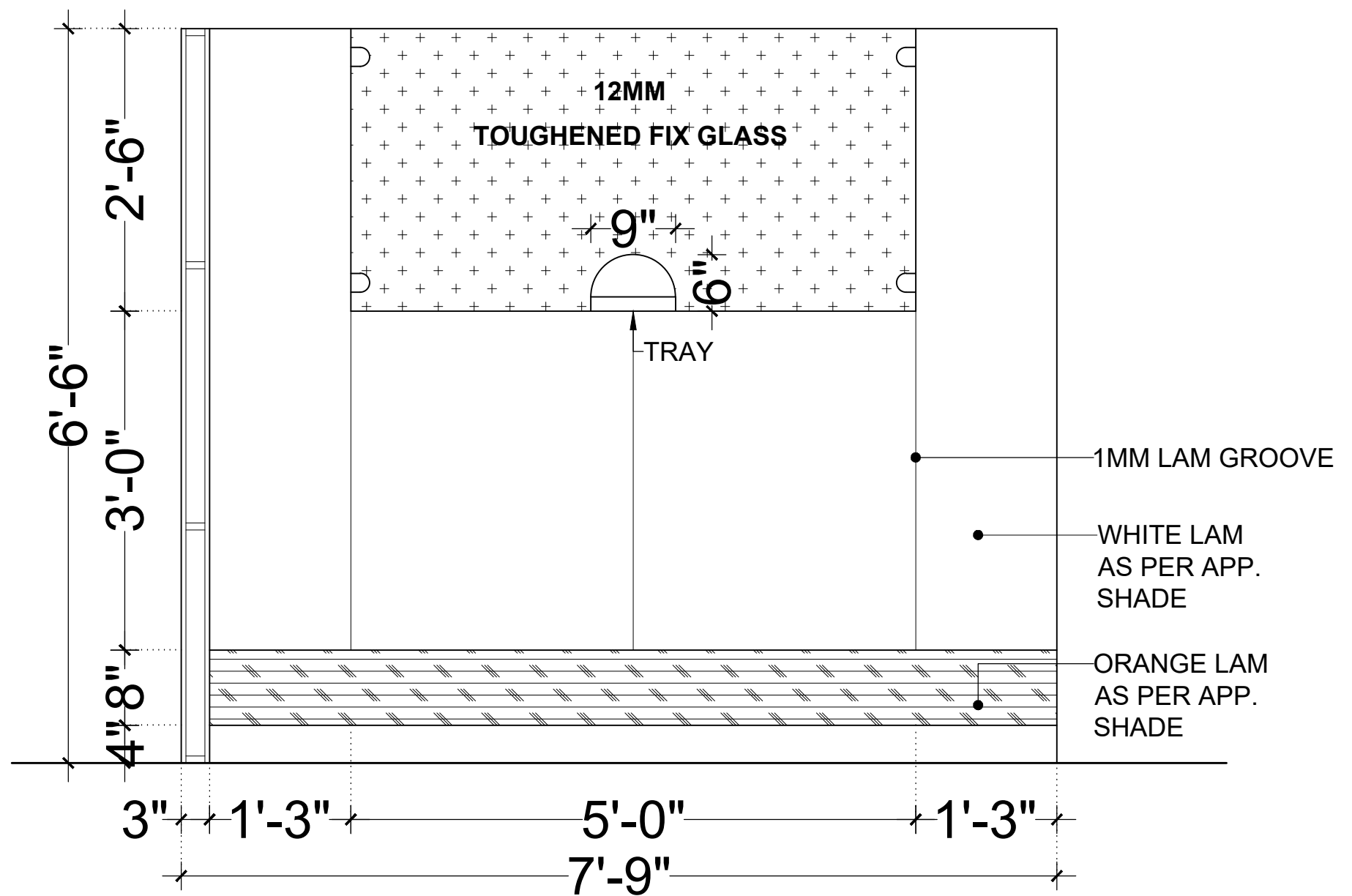

ELEVATION (PT4)

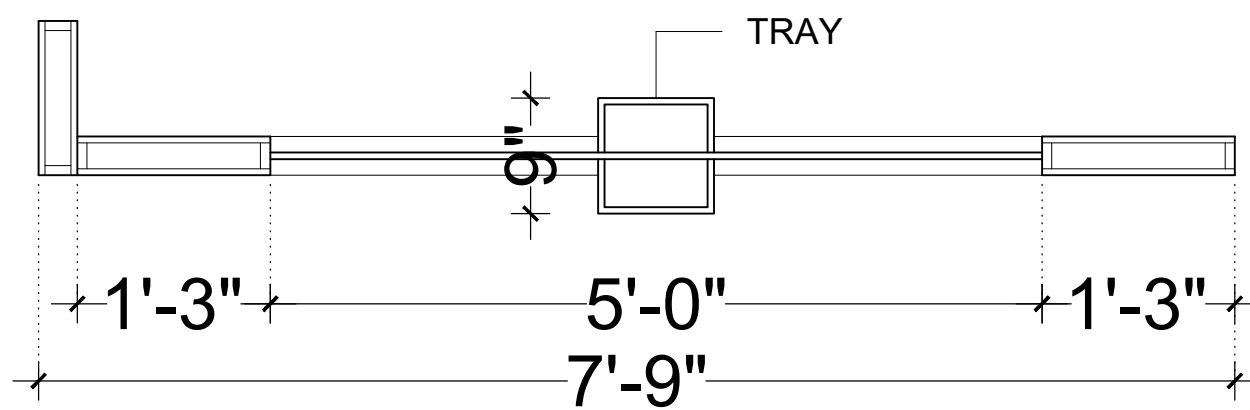

PLAN (PT4)

CASH PARTITION DETAIL (PT4)

NOTE :- CHECK DIMENSION AT SITE BEFORE EXECUTION

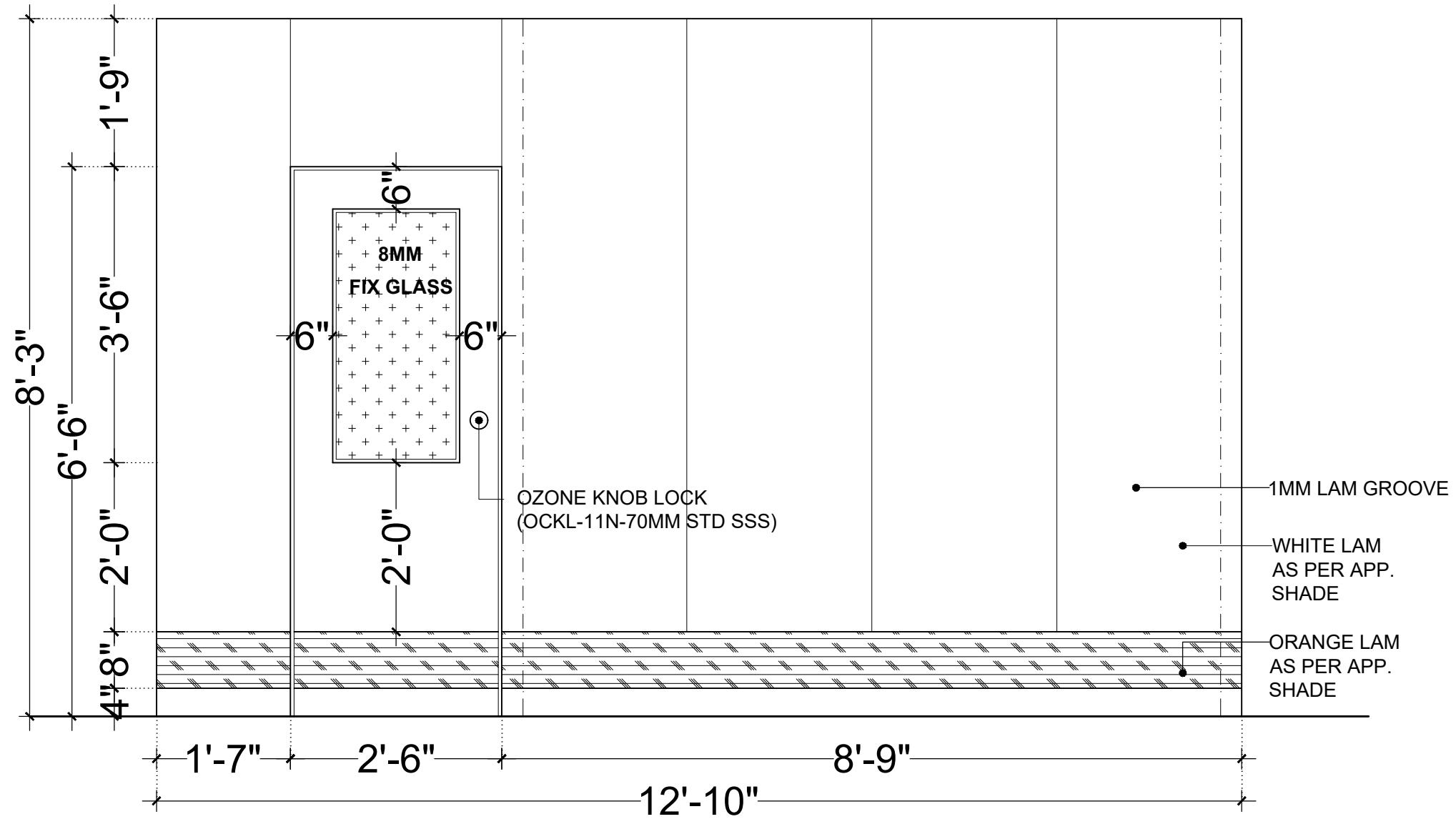

ELEVATION (PT5)

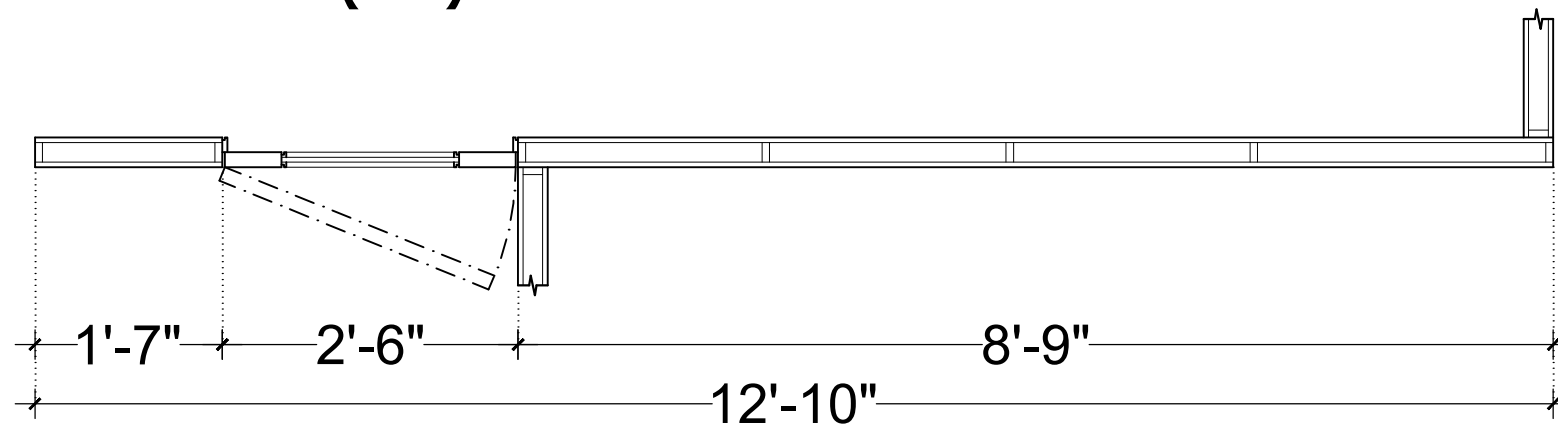

PLAN (PT5)

CASH PARTITION DETAIL (PT5)

NOTE :- CHECK DIMENSION AT SITE BEFORE EXECUTION

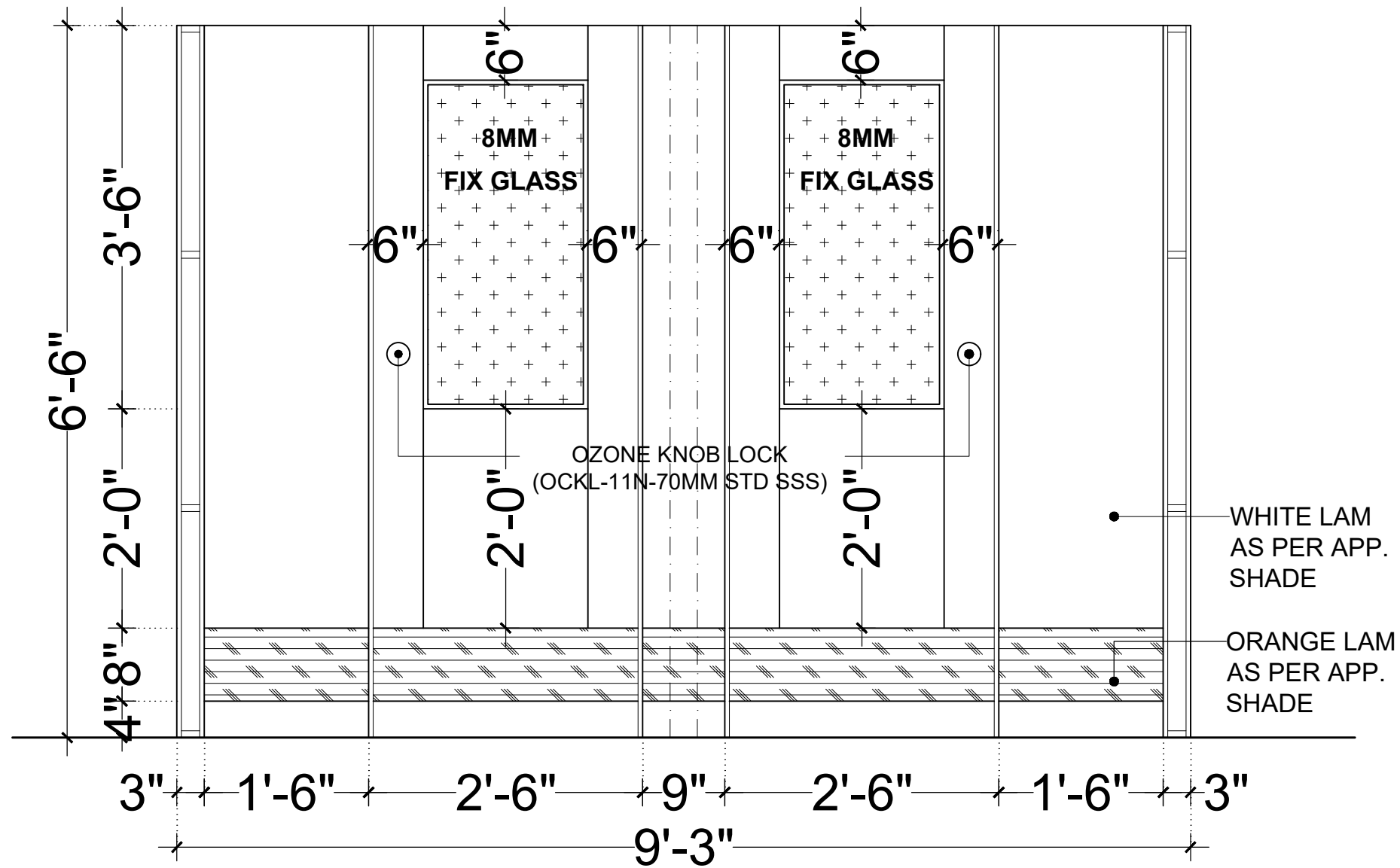

ELEVATION (PT6)

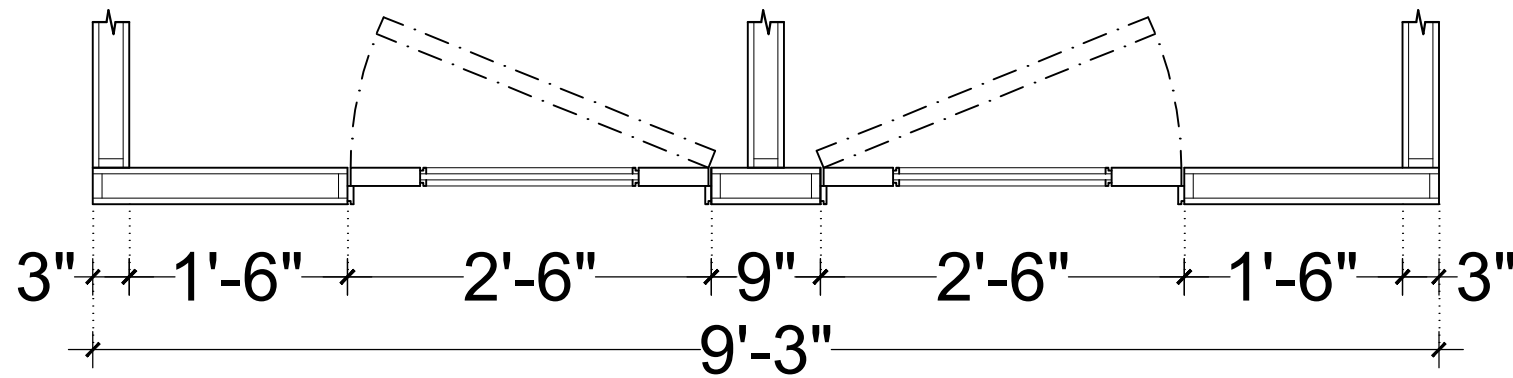

PLAN (PT6)

CASH PARTITION DETAIL (PT6)

NOTE :- CHECK DIMENSION AT SITE BEFORE EXECUTION

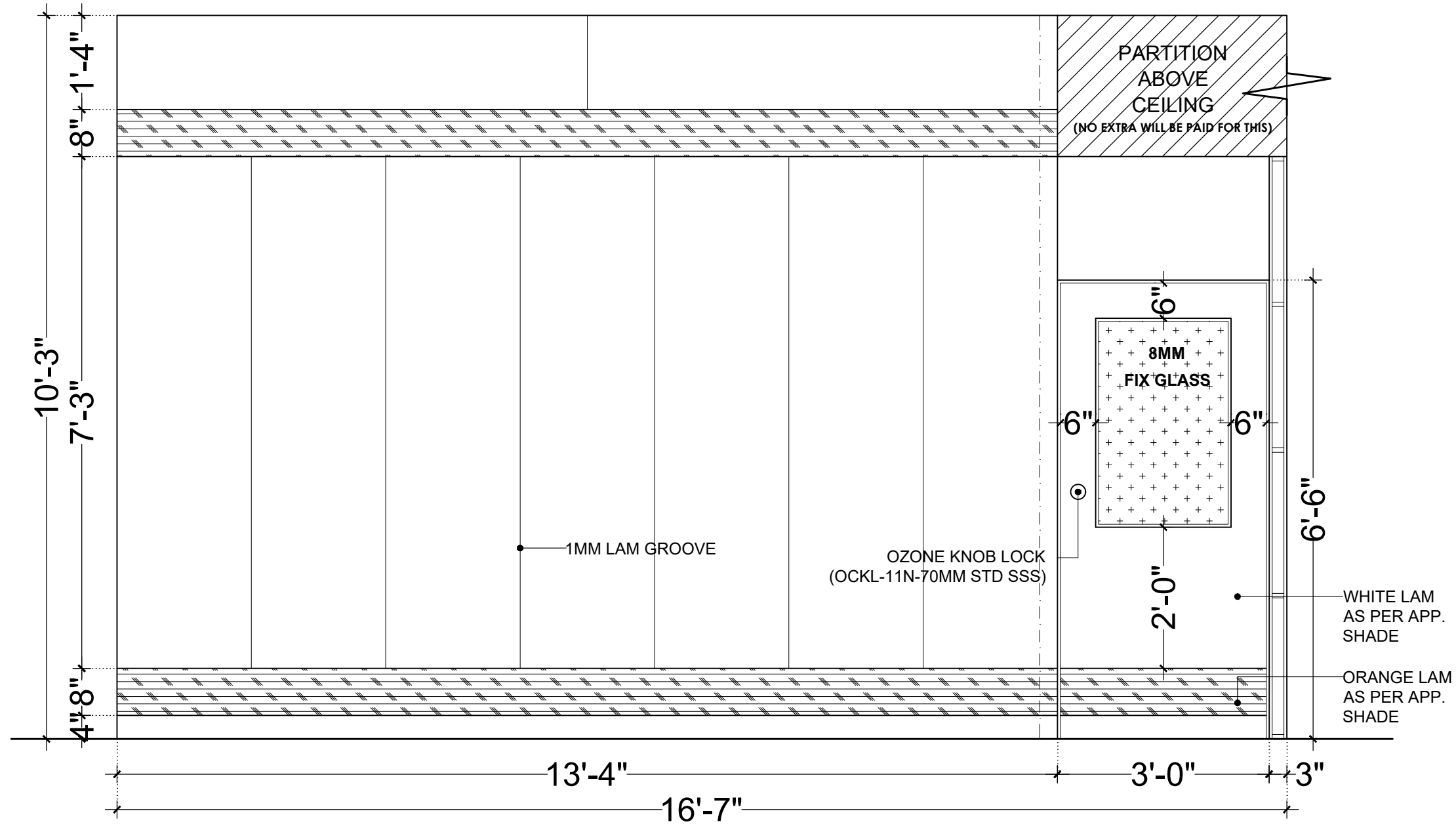

ELEVATION (PT7)

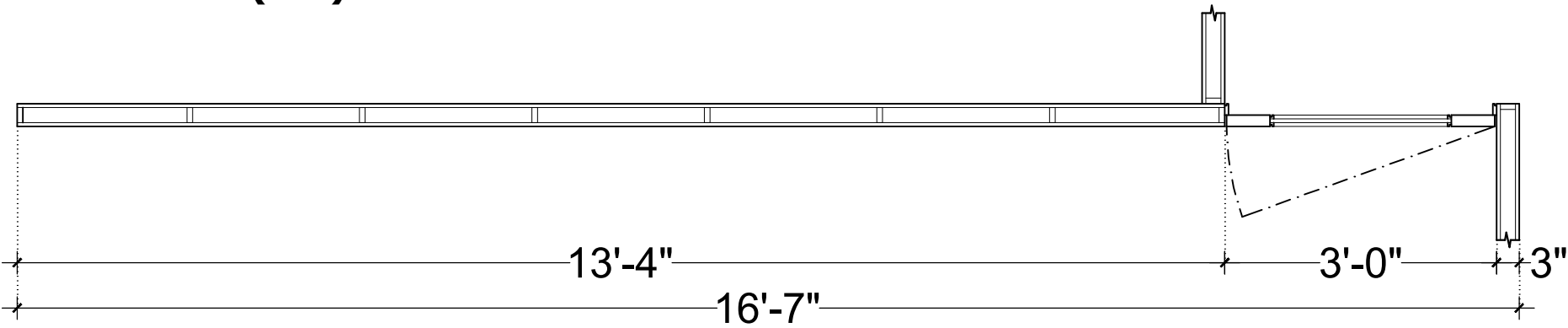

PLAN (PT7)

RECORD ROOM PARTITION DETAIL (PT7)

NOTE :- CHECK DIMENSION AT SITE BEFORE EXECUTION

Anil Vadgama
Architect
96241 67971

V n B Designs
Architecture & Interior
210, Nakshatra II commercial complex, opp.k.v.hall,150 feet wide ring road,
rajkot-360 005.
e-mail : vnbdesigns@rediffmail.com.

GROUND PLAN; INTERIOR LAY-OUT PLAN
of proposed bank building
for Bank of Baroda , UPLETA BRANCH
UPLETA.

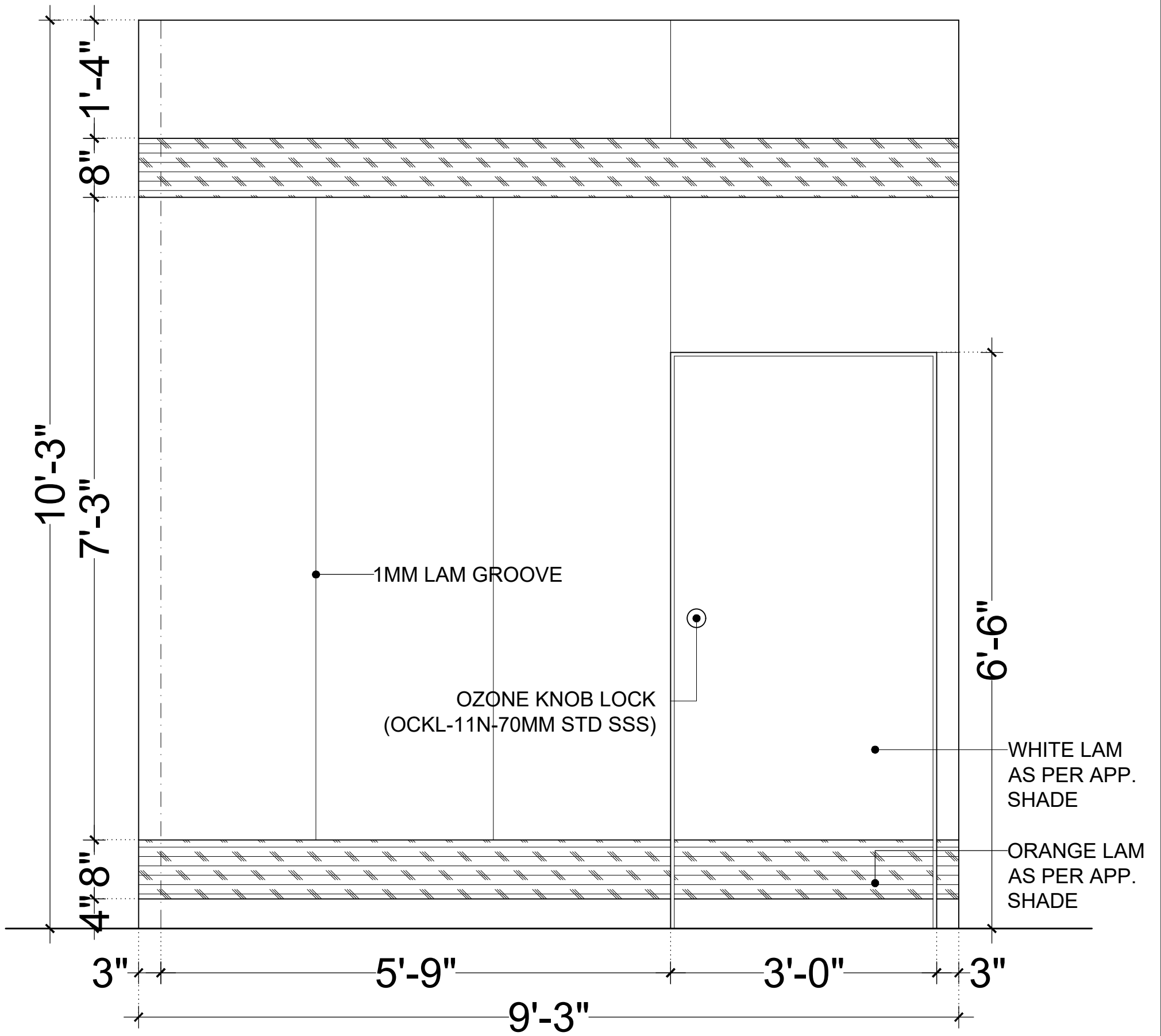

ELEVATION (PT8)

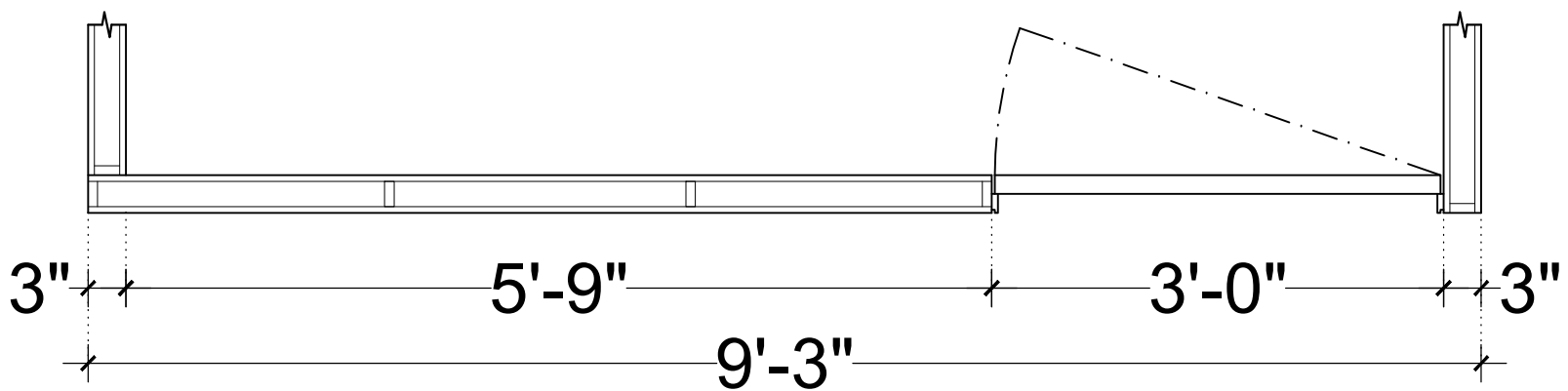

PLAN (PT8)

RECORD ROOM PARTITION DETAIL (PT8)

NOTE :- CHECK DIMENSION AT SITE BEFORE EXECUTION

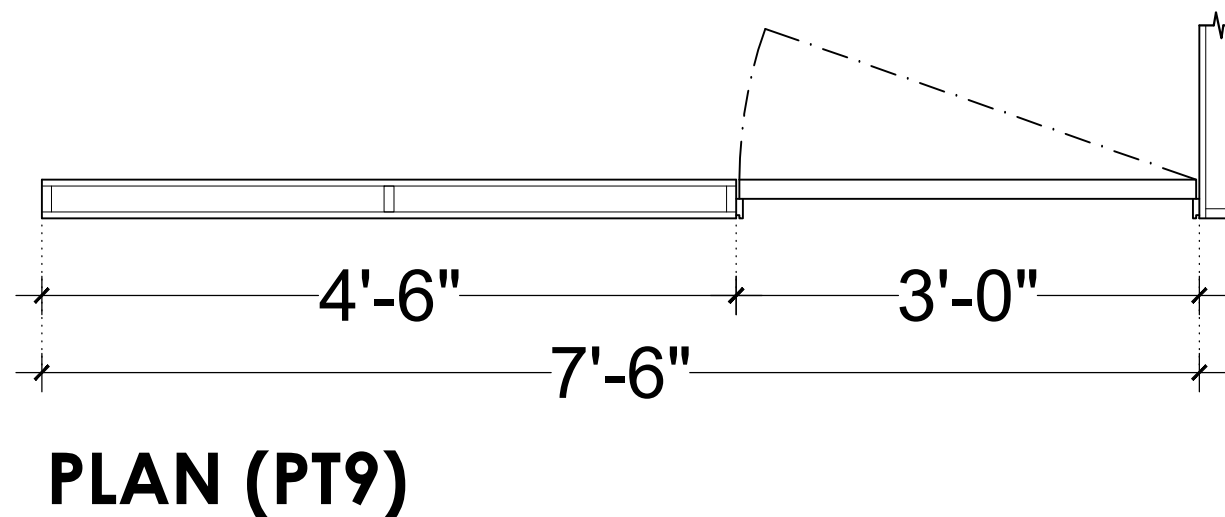
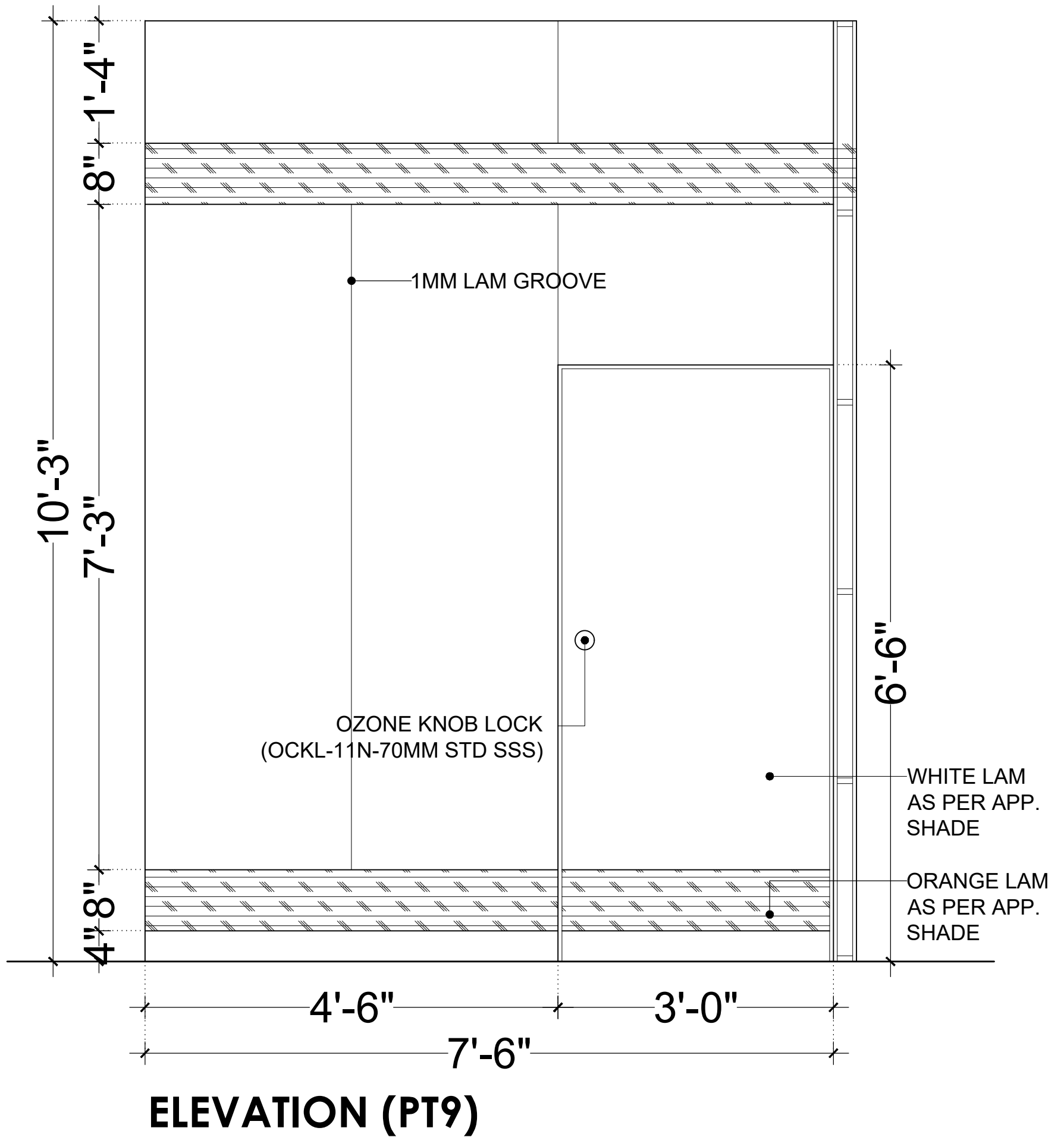

DENA LOCKER ROOM PARTITION DETAIL (PT9)

NOTE :- CHECK DIMENSION AT SITE BEFORE EXECUTION

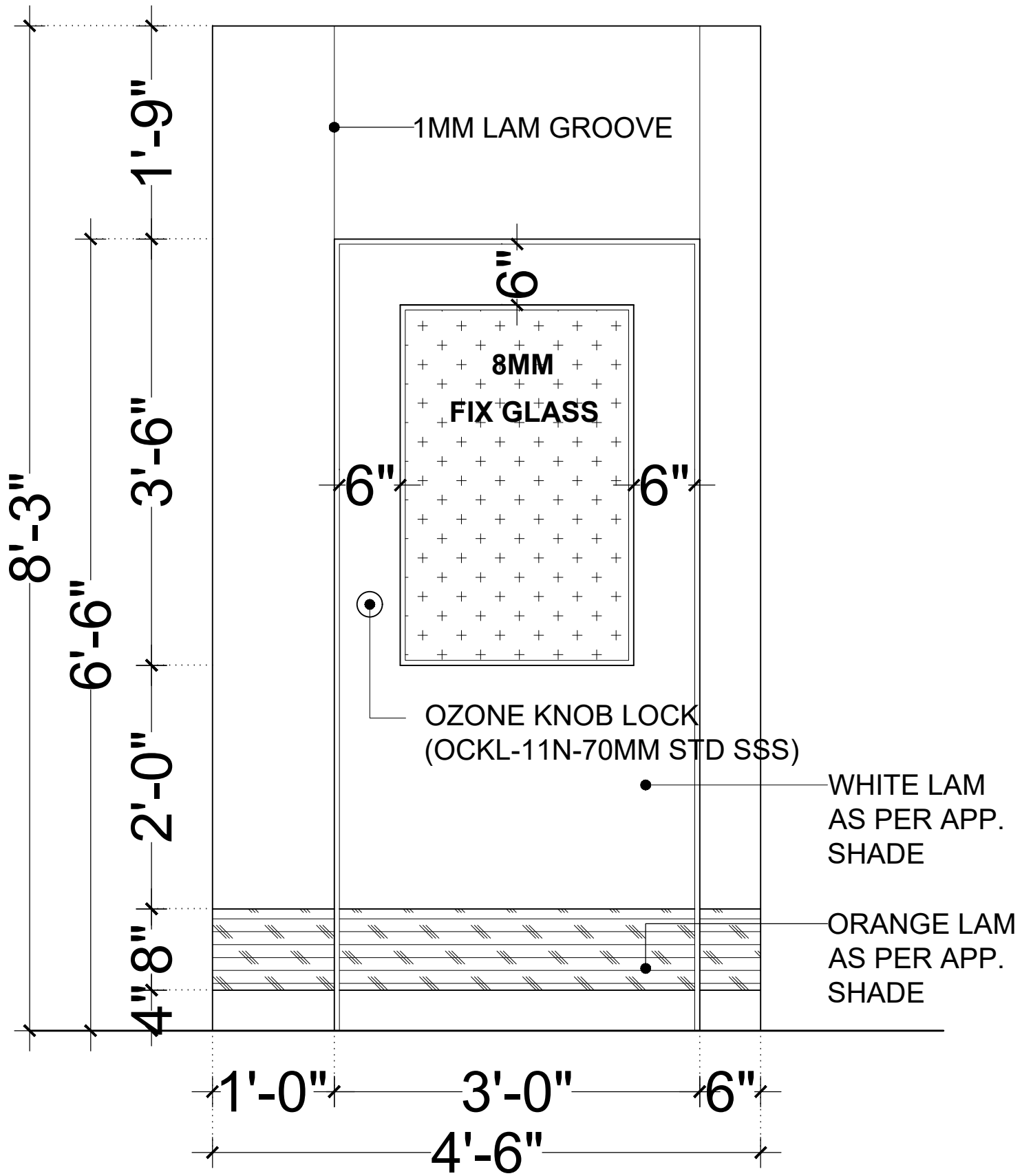

ELEVATION (PT10)

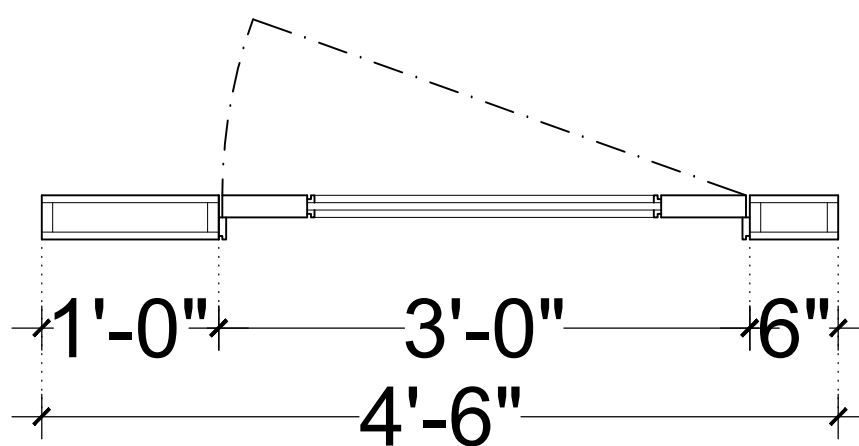

PLAN (PT10)

TOILET PARTITION DETAIL (PT10)

NOTE :- CHECK DIMENSION AT SITE BEFORE EXECUTION

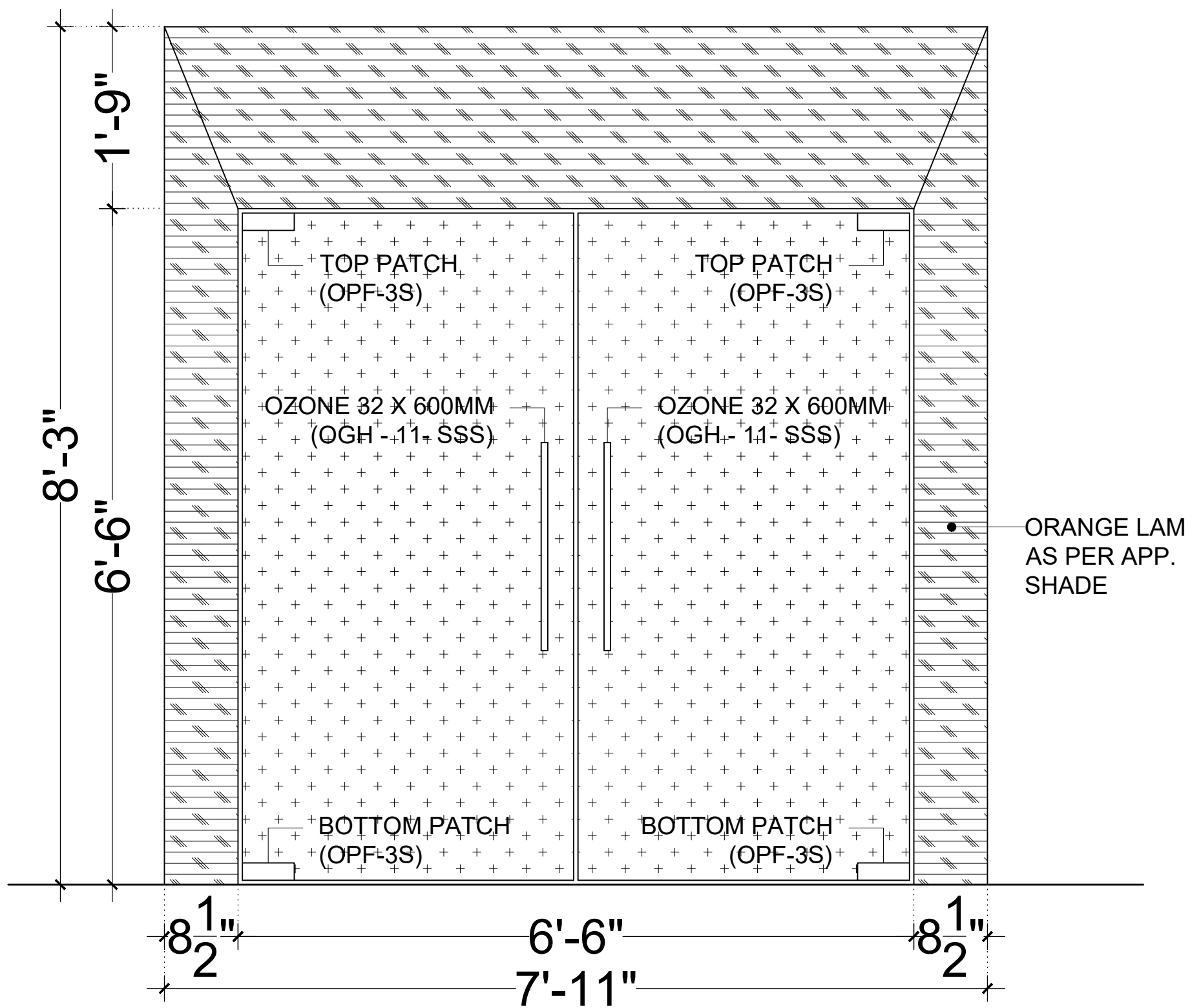

ELEVATION (PT11)

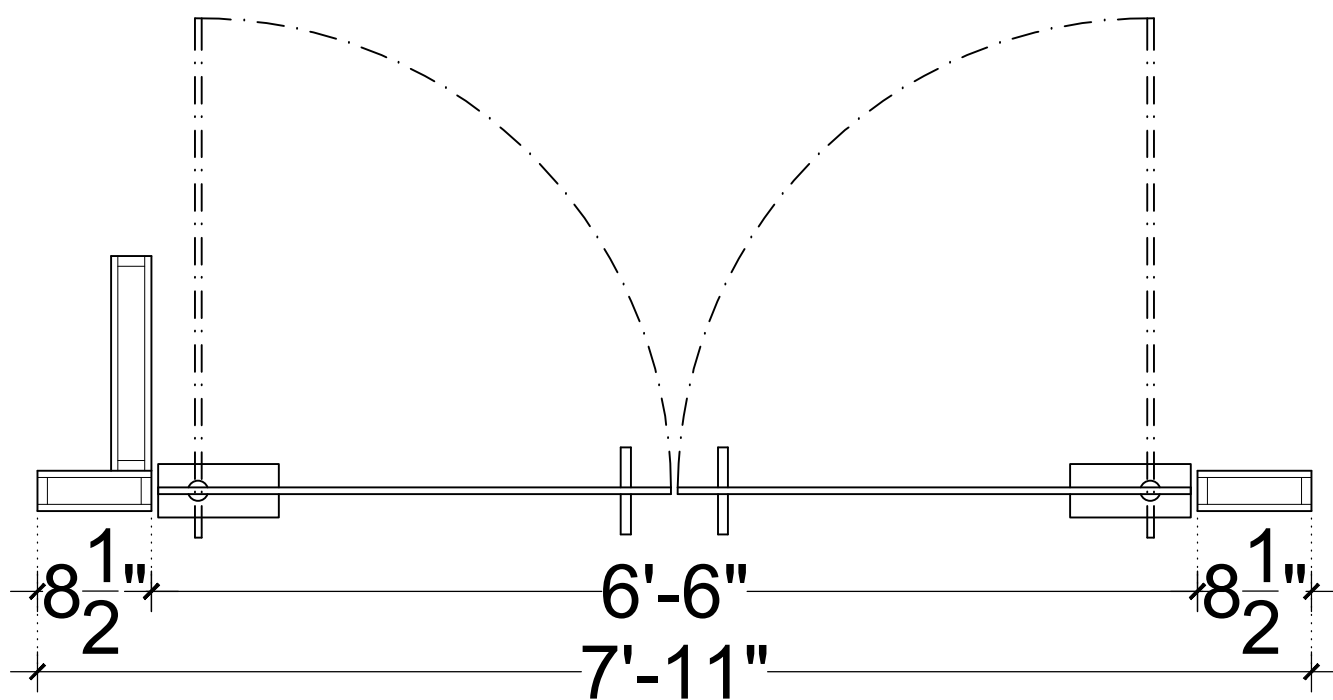

PLAN (PT11)

MAIN DOOR PARTITION DETAIL (PT11)

NOTE :- CHECK DIMENSION AT SITE BEFORE EXECUTION

GROUND PLAN; INTERIOR LAY-OUT PLAN
of proposed bank building
for Bank of Baroda , UPLETA BRANCH
UPLETA.

Anil Vadgama
Architect
98241 67971

V n B Designs
Architecture & Interior
210, nakshatra II commercial complex, opp.k.k.v hall, 150 feet wide ring road,
rajkot- 360 005. e-mail : vnbdesigns@rediffmail.com.