



**TENDER FOR INTERIOR FURNISHING, ELECTRICAL & AIR
CONDITIONING WORKS FOR KOTAIYUR BRANCH**

**ENVELOPE -II
(PRICE BID)**

**Tender will be addressed to The Regional Head, Chennai Rural
Region, No.123 RL Road, 1st Floor, Dugar Towers,
Egmore, Chennai-600 008.**

Tenders to be submitted to the following address

**THE REGIONAL HEAD,
BANK OF BARODA,
CHENNAI RURAL REGION,
NO.123 RL ROAD, 1ST FLOOR,
DUGAR TOWERS, EGMORE
CHENNAI-600008.**

TSO DESIGN COMMUNE PVT LTD

Architects• Planners• Interior Designers

N.NO.16, O.NO.42, GROUND FLOOR

SOUTH WEST BOAG ROAD, T. NAGAR,

CHENNAI – 600 017

PH: 044-24350493

MAIL ID: INFO@TSODC.COM

**SUMMARY FOR PROPOSED INTERIOR, ELECTRICAL AND AIR CONDITIONING
WORKS FOR KOTAIYUR BRANCH, BANK OF BARODA, CHENNAI.**

INTERIOR WORKS TOTAL	
ELECTRICAL WORKS TOTAL	
AIR CONDITIONING WORK TOTAL	
TOTAL EXCLUDING GSTN	
CGST 9%	
SGST 9%	
GRAND TOTAL INCLUDING GSTN	

**BOQ FOR PROPOSED INTERIOR WORK FOR KOTAIYUR BRANCH, BANK OF
BARODA, CHENNAI.
FURNISHING WORK**

Sl. No	Descriptions	Qty.	Unit	Rate	
				Rate	Amount
1	GYPSUM False Ceiling :				
	<p>Gypsum False Ceiling : Plain gypsum board MR/FR grade ceiling: 12 mm thick Plain gypsum MR/FR grade false ceiling Suspension (considering all levels with require all fabricataion work and fitting from RCC slab to false ceiling level & The rate shall be considered in sqm for all floors and at all heights, offsets whether covelight or fixed gypsum board size up to 100 mm to 1200 mm in the false ceilings including all costs) . Work complete as per the manufacturers specification of Saint Gobain or approved make- M/F Suspended Ceiling 1 hour fire rated. Providing and fixing Suspended ceiling using Gypsum or equivalent of ULtra G. I. Perimeter Channels of size 0.55mm thick having one flange of 20mm and another flange of 30mm and web 27mm along with perimeter of ceiling, screw fixed to Cutouts For light fittings, grill diffusers shall be made. Necessary cutting / providing openings in the ceiling for AC fixtures, grills, electrical fittings, or other utility services, hatch openings etc. shall be provided by the Contractor and cost of making such modifications shall be included in the price. No separate charges for cutting / providing opening will be paid. Joints between the two gypsum board, (Board placed staggered) gypsum board and wall will have suitable tape and finishes with plaster of paris so as to have crack free joints.</p> <p>brick wall / partitions with the help of nylon sleeves and screws, at min. 600 mm centers. Then suspending G. I. intermediate channel of size 45mm, 0.9mm thick with two flanges of 15mm each from the soffit at 1220mm centers with ceiling angle of width 25mm x 10mm x 0.55mm thick fixed to soffit with G. I. cleat and steel expansion fasteners. Ceiling section of 0.55mm thickness having knurled web of 51.5mm and two flanges of 26mm each with lips of 10.5mm are then fixed to intermediate channel with the help of connecting clip and in direction perpendicular to the intermediate channel at 457mm centers. 12mm gypsum MR/FR grade Board (conforming to IS 2095 part 1 2011) is then screw fixed to ceiling section with 25mm dry wall screwed at 230mm centers. Screw fixing is done mechanically either with screw driver or drilling machine with suitable attachment. Finally the boards are to be jointed and finished so as to have a flush look which includes filling and finishing the edges of the boards with jointing compound, Joint paper tape .</p>				
	<p>The item includes providing and fixing trap door of size 600 X 1200 mm as per approved sample of Ceiling panels comprise of a powder-coated beaded steel frame with gypsum / plywood board door. Each panel features a push-latch closing mechanism with door retaining safety cable & hook.Suspenders from ceiling to support the frame and trap door firmly along with necessary hilti fastner, cleats, screws, angles, packing, etc. complete work. Work complete including all type of tools, tackles, finishing etc complete as per approved sample & instruction of Architect/ Client/ PMC. sample mock shall be approved from Architect/ Client. The ceiling to be completed ceiling with 3 coats of plastic emulstion paint over a primer coat.</p>	430	1Sft		
2	MODULAR FALSE CEILING - ARMSTRONG / equivalent make				

	<p>Armstrong Classic Lite H1892M with “Suprafine Silhouette” detail.</p> <p>Location: ME-lobby, Banking area and service areas.</p> <p>Size: 600 mm x 600 mm (tile size).</p> <p>Material specifications: Size: 600 mm x 600 mm and 15 mm thk. Sound absorption (NRC): 0.55 Light reflectance of > 84% (WT) Thermal conductivity k = 0.052 - 0.057 W/M0k Humidity resistance = 99% having fire performance Class O / Class 1 (BS 476). Surface: 3 coats of white paint. Back Side: Sanded & one coat of paint.</p> <p>MODULAR CEILING: Providing and fixing modular false ceiling tiles of 600 mm x 600 mm centre to centre and 13 mm thick square mineral fibre board to be fixed on frame work of Aluminium sections for suspended false ceiling consisting of Aluminium T 2” X 1 1/2” (50 mm X 40 mm) weighing 0.39 kg/m at 60 cms centre to centre and fixed with 1/2” x 1/2” (15 x 15 mm) flanges weighing 0.19 kg/m suspended on 6 mm dia. mild steel rod weighing 0.22 kg/m, fixed on wall and beams including rounding of the edges with aluminium T of 2” x 1 1/2” (50 mm x 40 mm) weighing 0.39 kg/m etc. (All aluminium sections shall be anodized/powder coated) including all labour, material, lifts etc. complete. Make - Armstrong or equivalent make</p>				
3	PARTITIONS				
	Note: The contractor shall be paid for the partition area upto to the false ceiling bottom only and the rate shall be inclusive of frame work for the partition above false ceiling and upto RC ceiling level.				
3a	Full Height Glazed Partition (Manager)				
	<p>Location: Front façade and BM cabin.</p> <p>Size: Full height. Minimum height shall be 8’0” and the maximum height shall be 10’0” or ceiling height</p> <p>Material: 12 mm thick. Toughened glass with Aluminium glass profile of Enox glazing profile EAPS- 1032 or equivalent make at bottom of the floor and the top below the ceiling.</p> <p>Providing and fixing in position in Aluminium section 50mm x 50mm 1.5mm thick of JINDAL/ INDAL make as internal frame structure placed horizontally & vertically in 550 mm x 550 mm or 600mm x 600mm center to center or as directed by the Architect. The vertical members shall be provided at the junction or every 2100 or 2400 mm or as directed by the Architect or as per the site requirements. The rate shall be inclusive of providing and fixing of 12mm thk toughened glass partition in position as indicated in the drawings. The glass shall be fixed securely with Aluminium glass profile of Enox glazing profile EAPS- 1032 or equivalent at bottom of the floor and inside the ceiling as per manufacturer’s specifications to the Architect’s satisfaction. Any damage to the newly laid flooring shall be reinstated and complete in all respects. (For Measurement only Installed area will be considered).</p>				
		78	1Sft		
3b	Solid Full Height Partition				
	<p>Full height solid partition with Laminate finish on both sides - Internal areas of the Branch.</p> <p>Location: Branch area and ME lobby area.</p> <p>Size: Full height. Minimum height shall be 8’6” and the maximum height shall be 10’0”.</p> <p>Material: 12 mm thk.Commerical ply partition.</p> <p>Finish: Internally and externally finished with 1.0 mm thk. Laminate equivalent make Frosty white G499 / 1499 or equivalent.</p>				

	Providing and fixing in position full height solid partition 75 mm thk. as indicated in the drawing excluding the door made out of aluminium hollow sections of 50mm x 50mm size 1.5mm thick of JINDAL / INDAL make as internal framed structure placed horizontally & vertically in 550 mm x 550 mm / 600mm x 600mm center to center or as directed by the Architect. The alternate corner vertical members of the partition shall be taken upto the ceiling level (payment shall be made for the partition measured below the false ceiling level) and the same shall be anchored to the ceiling securely with help of suitable cleats. Framework shall be fixed with 12mm thick Commercial ply of approved make on both sides finished as per following specifications. The Partition shall be finished with 1.0 mm thick laminate Sunmica make Frosty white G499 / 1499 of approved shade and make or equivalent on both the sides. Rate shall be inclusive of provision of pencil groove as directed by the Architect. Height of the partitions upto soffit of false ceiling / laminate finish top shall be considered for payment. Alternate, corner vertical members of the partition shall be fixed with necessary brackets /supports at RCC levels. The framework above the false ceiling shall not be considered for payment. The item does not include the doors.	452.38	1Sft		
4	WRITING LEDGE				
	Supply and fixing writing table and brochure holder of size 600mm x 530mm made of 12mm thick glass supported with 12mm thick Plywood stand finished with Duco paint. The glass to be beveled to half round shape and 6mm thick clear glass to be fixed in grooves.	2	1No		
5	WICKET GATE				
	Supply & fixing Wicket small door of width 3'-0" & height 4'0" made of 2"x2" salwood framework & screwed with 6mm thick Commercial ply on both sides, finished with approved colour of 1mm thick decorative laminate. The edges lipped with TW beading of size 1"x1/2" & finished with melamine polish after necessary surface preparation.	1	1 No.		
6	ROLLER BLINDS				
	The Blind system consist of a coated aluminium tube of 38 mm diameter with provision of fabric clamping. The Fabric is rolled up and down through a chain drive system with built in drive gear and an over run brake system. The side brackets are universal type suitable both for wall and ceiling mounting. The bottom end of the fabric is rolled over an oval shape aluminium tube with provision to lock the fabric.	0	1Sft		
7	CHEQUE DROP BOX				
	Supply and fixing a Cheque drop box as per specifications.	1	1No		
8	SUGGESTION BOX				
	Supply and fixing suggestion box as per specifications.	1	1No		
9	PIN-UP BOARD / SOFT BOARD Size: 3/2				
	It is useful for the staff to pin-up the important notices, memos and Bank's related information and which needs to be visible. Location: On the running or sales counters table – free standing and also acting as a divider, on partitions or walls adjacent to or in front of the cash teller or Branch Manager's cabin. Material: 15 mm thick Pin-up board (soft board) with 12 mm thick Ply backing covered with approved coloured "Vermillion / Beige colour" fabric supported on SS supports. Maintenance: All surfaces should be cleaned with dry cloth/ duster daily with a soft damp cloth dipped in a mild soap solution.	2	1No		
10	ENTRANCE DOOR				

	<p>Location: Main entry;</p> <p>Size: Main door - Average size – SINGLE leaf – 1067 mm width x 2400 mm (min.) height.</p> <p>Material: 12 mm thk. Clear edge polished toughened glass.</p> <p>Hardware: SS Floor Spring, Latch lock/Dead Lock (Bottom or centre) , SS Handle “H or D” type (900 Long and 25 mm dia).</p> <p>Installation of fully glazed frameless glazed door (Single or double leaf of size as mentioned in drawing and as directed by the Architect) made out of 12 mm thk. Toughened glass and the door shall be fixed with Dorma ,Hafele , Enox or approved make floor springs with SS finish patch fittings on top, bottom. Lock shall be of Dorma , Hafele , Enox or approved make. The door shall have lock in the center of approved make with 450 mm to 600 mm long SS handle of 25 mm dia. (for internal doors) and 900 mm long SS handles of 25 mm dia. (for main entry doors) to be fitted horizontally/ vertically as per instructions of the Architect. The Rate shall be including the making of necessaryholes in glass for Access control locks, complete in all respect with all hardware, fittings, fixtures etc. complete in all respects. All necessary hardware, fittings, fixtures to be approved from the Architect or Bank’s Officials before actual application of the same. Any change in the specifications must be first approved from the Architect and the Bank.</p>	30	1Sft		
11	GLAZED DOOR (manager Cabin)				
	<p>Supply and Installation of fully glazed frameless glazed door (Single or double leaf of size as mentioned in drawing and as directed by the Architect) made out of 12 mm thk. Toughened glass and the door shall be fixed with Dorma ,Hafele , Enox or approved make floor springs with SS finish patch fittings on top, bottom. Lock shall be of Dorma , Hafele , Enox or approved make. The door shall have lock in the center of approved make with 450 mm to 600 mm long SS handle of 25 mm dia. (for internal doors) and 900 mm long SS handles of 25 mm dia. (for main entry doors) to be fitted horizontally/ vertically as per instructions of the Architect. The Rate shall be including the making of necessaryholes in glass for Access control locks, complete in all respect with all hardware, fittings, fixtures etc. complete in all respects. All necessary hardware, fittings, fixtures to be approved from the Architect or Bank’s Officials before actual application of the same. Any change in the specifications must be first approved from the Architect and the Bank.</p>	25	1Sft		
12	FLUSH DOOR				
	<p>Supply and installation of 45mm -50mm of size 3'-0" x 7'-0" Shutter shall be finished with 1.0 mm thick. Laminate of equivalent make Frosty white G499 / 1499 along both sides of approved shade and design. Door shall be lipped with 12 mm thick. t w beading along the edges. There shall be a provision of vision panel of 8 – 10 mm thick. Clear glass of size 150 mm x 150 mm with 12 mm tw beading around. Rate shall be inclusive of hardware, fittings, fixtures etc. in heavy duty SS such as lock of 6 lever of Godrej or Doorset make with SS mortise handle of approved make and model. Rate shall be inclusive of open door closers, SS heavy duty hinges, tower bolts, SS foot operated door stopper, SS buffer along the back side and any other related hardware , fittings, fixtures etc. required. The item shall include polishing of edges and frames in melamine , PU , paint as approved by the Architect.</p>	84	1Sft		
13	FRONT Glazing: Providing and fixing external fixed glazing comprising of 12mm thick toughed glass with top, bottom and	30	1Sft		

	vertical frame comprising of black powder coated aluminium members, glass to be laminated with clear antishatter film on one side. Approximate 100mm top & bottom member, approximate 100mm vertical members.				
14	Coloum Panelling				
	Providing and fixing of wall panelling directly on the wall surface with or without any frame work with 12mm thick commercial grade ply and then finished with 1.0 mm thick laminate of equivalent make frosty white . If the frame work is required it shall be aluminium hollow sections of 50mm x 50mm size 1.5mm thick of JINDAL /INDAL make as internal frame structure placed horizontally & Vertically in 550 mm x 550mm or 600mm x600mm center to center or as directed by the architect. All wood work and laminate shall be finished with two or more coats of melamine or PU polish over one coat of sealer; all complete as per the instructions of Architect. The rate shall be inclusive of provision of groove with 1.0mm thick laminate along all 3 side of the goove in the panelling of size 12mm x12mm x18mm ht. and as directed by the architect this item also includes scaffolding of maimum ht upto 4.0m from floor level.	173	1Sft		
15	LUNCH PLATFORM				
	Providing and laying platform of length 8'-0" to 1'-6" width (clear) and at 3'-6" height (top) above FFL. of approved 20mm thick granite with bull nosed edge. It shall be laid on 18mm thick Commerical ply and steel L angle bracket. The platform shall be cantilevered from the wall as shown in the drg. The edge of the platform should be double edged with half round machine polished. 9" wide 18mm thk Commerical ply to be provided below the entire lunch counter for shelves for Tiffin's and kitchen items.	8	1Rft		
16	Boxing for rolling shutters				
	Supply and installation of Aluminium composite panel (ACP) of 4 mm thickness and approved manufacture (GREY coLour) on a backing of 2" x 1 1/2" aluminium frame work 2mm thickness in section, including all installtion complete.	110	1Sft		
17	Storages: 2' 6" Ht & 7'0" Ht				
	Fabricated with 18MM thk Ply with 1.00MM thk laminate for Shutters, Side Supports, intermediate loose shelves, exposed edges with PVC Edge binding with trimmed, and back 6MM thk ply finished with 1.00MM thk of approved color and shade. The innder portion to be fix with 0.8 thk laminate. The rate includes 4" SS Handle, Mulitpurpose Locks, Box hinges, Tower bolts, inside stoppers, etc., The entire work to completed as per design and instruction of the Architect.	57.5	1Sft		
	Total (Excluding GST)				

BOQ FOR PROPOSED ELECTRICAL WORK FOR KOTAIYUR BRANCH, BANK OF BARODA, CHENNAI.

ELECTRICAL WORK

Sl. No	Descriptions	Qty.	Unit	Rate	Amount
1	LIGHTING AND POWER WIRING				
1.1	Supply, wiring, testing and commissioning of Light points with 3R 1.5Sqmm, PVC insulated FRLS copper wire in a PVC conduit for P/N/E along with Modular 6A one way switch with molled front plate GI anodized enclosure and other associated accessories as required as per the site conditions, etc.,				
a)	One switch controlled by One light.	16	P/Pt.		
b)	Two Switch Controlled by one Light	18	P/Pt.		
c)	Fan / wall mounted fan / exhaust fan	11	P/Pt.		
d)	Switch board plug print	7	P/Pt.		
1.2	Supply, laying, testing and commissioning of 3R of 2.5Sqmm PVC insulated FRLS multistrand copper wire in as required at site in 2mm thick PVC conduit for UPS socket. Not more than 2 UPS Point to be connected to one circuit, etc.,	175	P/Mtr		
1.3	Supply, laying, testing and commissioning of 3 runs of 2.5Sqmm PVC insulated FRLS multistrand copper wire in 2mm thick PVC conduit as required at site for Raw power sockets. Not more than 4work station point to be connected to one circuit.	175	P/Mtr		
1.4	Supply, laying, testing and commissioning of 3 runs of 2.5Sqmm PVC insulated FRLS multistrand copper wire in PVC conduits as required at site for Lighting Mains, etc.,	150	P/Mts.		
1.5	Supply, laying, testing and commissioning of 2 runs of 4Sqmm. And 1 run of 2.5Sqmm PVC insulated FRLS multistrand copper wire in PVC conduits as required at site for AC power.	150	P/Mtr.		
1.6	Supply, laying, testing and commissioning of 3 runs of 6Sqmm. PVC insulated FRLS multistrand copper wire in PVC conduits as required at site for UPS Main	40	P/Mtr.		
2	POWER PLUGS AND SOCKETS				
2.1	Supply, installation, testing and commissioning of 4 Nos. 6A socket controlled by 1No 16A switch with molded front plate GI anodized enclosure and other associated accessories in the work station as required as per the site conditions.(UPS POWER)	8	P/Set		

2.2	Supply and fixing of 6A switch, sockets modular type with molded front plate GI anodized enclosure and other accessories associated chasing embedding rough plastering as required as per the site conditions.	9	P/No		
2.3	Supply and fixing of 16/6A, socket with switch modular with molded front plate GI anodized enclosure and other accessories associated chasing embedding rough plastering as required as per the conditions.	3	P/No		
2.4	Supply, erection, testing and commissioning of 40A DP MCB with enclosure for UPS input control.	2	P/Set		
2.5	Supply and fixing of 20A-metalcald plug and socket with 32A DP MCB in a PVC enclosure for split AC control.	4	P/Set.		
3	PANELS AND DISTRIBUTION BOARDS				
	MAIN PANEL				
3.1	Designing, fabrication, supply, installation, testing and commissioning of front operated cubicle type compartmentalized, front access, free standing on 75MM "I" MS channel, dust and vermin proof (IP 42 degree protection) panel suitable for use at 415V, 3 phase, 4-wire 50Hz system suitable for fault level of required value symmetrical at 415V fabricated from 2mm thick CRCA MS sheets with hinged, gasketted (Metal based neoprene) lockable doors having structural reinforcement including 3mm thick gland plates on top and bottom, lifting hooks, GI earth strip of required size with 2 no's earth terminals, 2 no's 230V AC operated 250 mm X 250 mm size axial fans for exhaust of heat with On-Off toggle switches including 2 coated primer and 2 power coated paint finish of approved shade over metal surface cleaned and treated with seven tank process complete with interconnections etc. as per specifications as required. Main panel board of approved make (Should be CPRI Approved, Type of Approval as instructed by the concerned office in charge)				
	As per the following specifications, (Part IV - Substation) and IS: 8623 comprising of followings panel mounting switchgears etc. as required, should be CPRI Approved. IS: 8623 comprising of followings panel mounting switchgears etc. as required, should be CPRI Approved. Note: Type of CPRI testing shall be as per Architect/ Bank's instructions. All switchgears shall have provision for entry of cables from the top or bottom through Cable Alley.				
	All live accessible parts shall be shrouded and all equipment shall be finger touch proof. The busbars insulation shall be with heat shrinkable sleeves SMC/ DMC shrouds and busbar supports shall be used. Padlocking facility shall be provided on all outgoing feeders' doors and switch handles shall be lockable in OFF position.				
	Suitable arrangement shall be made for termination of multiple incoming cables.				
	All KA values indicated shall be ICS breaking capacity				
	GA drawings shall be got approved by concerned office in charge.				
	Floor panel shall consists of :-				

	INCOMER				
	1 no. 125 Amp 4P On Load Change over switch with 1 No. 125 Amps, TPN MCCB (25 KA) with extendable rotary handle each thermal over current, instantaneous, Short circuit release, Earth fault.				
	BUSBARS				
	125 amps TPN pole bus bar chamber of suitable length with copper bus bars. All bus bars and interconnections shall be of suitable size copper strips.				
	INDICATING PANEL				
	Digital flush type class-1.0 accuracy multifunction meter showing V, A, PF etc. with 3 Nos. Current Transformers of 125/5A ratio, 15 VA Class-1.0 metering. - 1 sets				
	Red/Green/Amber ON/ OFF/ TRIP indicating lamps with 2A SP MCB backup protection.				
	1 set of three phase indicating lamps along with 2A SP MCB backup protection.				
	Restricted Earth fault relay with 3 Nos. current transformers of 125/5 ratio, 15 VA Class 5P 10				
	(Numeric Relay not required.)				
	Under voltage, Overvoltage & phase reversal relay for persisted voltage of 105-180% & 20-95% of rated voltage (Numeric Relay not required).				
	OUTGOINGS:-				
	2 Nos 40 A 4P MCB (10 kA) terminals suitable to receive cable on one side and wire connection to Bus bars. (For Spare)				
	2 Nos 40 A DP MCB (10 kA) terminals suitable to receive cable on one side and wire connection to Bus bars.				
	2 Nos 25 A DP MCB (10 kA) terminals suitable to receive cable on one side and wire connection to Bus bars.				
	3 Nos 63 A 4P MCB (10 kA) terminals suitable to receive cable on one side and wire connection to Bus bars. (for AC and Power DB)				
	The electrical panel as described above and specifications complete.	1	Set		
	DISTRIBUTION BOARD				
	Supplying, installing, testing & commissioning of surface/recessed mountings, Double door 415 volts TPN MCB distribution board of steel, 1.6 mm thick dust phosphatized and painted, inclusive of 100 amps, tinned copper bus bars, earth bar, common neutral link, din bar for mounting of MCB's detachable gland / knock out plate & with built in loose wire box, and superior make terminal connectors for all incoming and outgoing circuits duly prewired with adequate size of PVC insulated copper wires between the bus bars and the MCB's as well as the incomer and upto the terminal connectors/ neutral link and ready for installation of following ways as required.				
	Use 'B' curve MCB's for lighting & small power circuits, 'C' curve for motor duty i.e. for pumps, AC motors, window and split AC's etc. & 'D' curve for UPS DB's i.e. for computers/ PC's circuit. Main incomer & outgoing circuit MCB's shall be selected accordingly i.e. type B, C & D. Contractor to select the MCB's accordingly as per the nature of the circuit/ load.				

	Each DB shall have separate neutral links of rating not less than 100A for each phase. The main incoming neutral link shall be in addition to three outgoing neutral links and shall be of 125 A.				
	UPS DB's shall have a dedicated Earthing link fixed on insulated supports, which will be in addition to body earth link.				
	All internal inter connecting wiring within the DB's shall be PVC insulated flexible copper conductor wires of adequate capacity as per the current rating.				
	Inside each DB, a DB chart is to be fixed.				
3.2	4-way TPN DB (LIGHT DB)				
	Incomer:-				
	1 No. 32 Amp 4P (10 KA) MCB with 25 A DP RCCB (100 MA) each phase				
	Outgoing:-				
	12 Nos.6/10 Amp (10 KA) SP MCB	1	Set		
3.3	4-way TPN DB (POWER DB)				
	Incomer:-				
	1 No. 63 Amp 4P (10 KA) MCB with 63 A DP RCCB (100 MA) each phase				
	Outgoing:-				
	12 Nos.16/20 Amp (10 KA) SP MCB	1	Set		
3.4	8 -way SPN DB with 6 Nos. 40 A (10 KA) DP MCB (For UPS MAIN DB)	1	Set		
3.5	(8)-way SPN DB (For UPS Sub DB)				
	Incomer:-				
	1 No. 40 Amp DP (10 KA) MCB				
	Outgoing:-				
	6 Nos.6/10/16/25Amp (10 KA) SP MCB	1	Set		
4	CABLES				
4.1	Supplying, laying, testing & commissioning of 4 C X 10 sq.mm. at 1100 volts grade PVC insulated aluminum conductor armoured cable with 8 gauge earth copper wire as required. (Light DB).	20	P/Mtr		
4.2	Supplying, laying, testing & commissioning of 4 C X 25 sq.mm. at 1100 volts grade PVC insulated aluminum conductor armoured cable with 8 gauge earth copper wire as required. (Power + AC DB).	23	P/Mtr		
4.3	Supplying, laying, testing & commissioning of 3.5 C x 70 sq.mm. at 1100 volts grade PVC insulated aluminum conductor armored cable with 8 gauge earth copper wire as required. (Mains)	50	P/Mtr		
5	END TERMINATION				
	Supply & terminating the ends of cables of following sizes using seimens type single compression cable glands,				

	crimping type Aluminum/Copper sockets of required size, gland earthing clips complete.				
5.1	3.5C x 70 Sqmm. Al. Ar. Cable	2	P/Set		
5.1	4 C x 25 Sqmm. Al. Ar. Cable	2	P/Set		
5.1	4 C x 10 Sqmm. Al. Ar. Cable	2	P/Set		
6	LIGHT FITTINGS AND FANS				
	Supply & fixing of the following light fittings with all accessories, tubes, ballast's, suspension wires from ceiling, false ceiling, anchor fasteners, chains, bolts, nuts etc.,				
6.1	Supply and erection of 36 watts 2' x2' LED light fitting with fixture (Philips, Wipro, Crompton)	12	P/No		
6.2	Supply and erection of 1 x 20 watts LED (Philips, Wipro, Crompton)	11	P/No		
6.3	Supply Installation of 1x15 W LED downlighter (Philips, Wipro, Crompton)	29	P/No		
6.4	Supply installation of 10 watts LED lamp light fitting.	2	P/No		
6.5	Supply & fixing of 9" exhaust fan. (Almonard)	3	P/No.		
6.6	Supply & fixing of 48" sweep ceiling fan with regulator (crompton Make)	4	P/No.		
6.7	Supply & fixing 18" dia Wall mounted fans including all wiring and installation of modular switches complete (Crompton make)Note: All work should be concealed and rate should take care of all civil works complete.	4	P/No.		
7	EARTHING				
7.1	Supply, installation, testing and commissioning of 2.5Mts long 40mm dia 'B' class GI earth electrode with 600 x 600 x 3mm copper plate, funnel clamps bus etc including excavation refilling with sand/ charcoal/ salt combinations complete as required including heavy duty cast iron cover and all associated civil works like construction of chamber and rough plastering etc as required.	2	P/No		
7.2	Supply, laying of 16Sqmm multi stranded FRLS copper wire in suitable PVC conduit with all accessories as required.	80	P/Mtr		
7.3	Supply, laying of 8 SWG bare copper wire	50	P/Mtr		
8	DATA / VOICE NET WORK				
8.1	Supply and laying of E CAT6 Network cable in PVC Conduits (Including conduits)	280	p/mtr.		
8.2	Supply and fixing of RJ45 Network socket with front plate and base box for computer workstations.	8	p/No.		

8.3	Supply and laying of 0.5mm two pair copper telephone cable in PVC conduit, etc., (Including conduits)	200	p/mtr.		
8.4	Supply and fixing of RJ11 telephone jack with front plate for all workstations.	8	p/No.		
8.5	Supply and fixing of 10 pairs-krone connector in a PVC powder coated enclosure with all associated accessories.	1	p/No.		
8.6	Supply and fixing of 3 feet patch card (Systimax)	8	p/No.		
8.7	Supply and fixing of 7 feet patch card (Systimax)	8	p/No.		
8.8	Supply and fixing of manageable 24 port switch. (Cisco make)	1	p/No.		
8.9	Supply and fixing of 24 port jack panel (Systimax make)	1	p/No.		
8.10	Supply and fixing of wall mountable Rack 12Uwith power adaptor etc.	1	p/No.		
9	INVERTER WIRING & INSTALLATION				
9.1	Supply & laying 3runs of 2.5Sqmm copper wire in suitable PVC conduits (ISI make) 18mm dia including all civil works complete	150	1Rm		
9.2	Supply & fixing 15Amps switch & socket (modular type) as per specifications complete	2	1No		
9.3	Supply and laying 3 runs of 4 Sqmm copper wire in suitable PVC conduits (ISI make) 18mm dia including all civil works complete	30	1Rm		
9.4	Supply & fixing modular type 5A switch as per specifications complete	5	1No		
TOTAL EXCLUDING GST					

BOQ FOR PROPOSED AIR CONDITIONING WORK FOR KOTAIYUR BRANCH, BANK OF BARODA, CHENNAI.					
AIR CONDITIONING WORK					
Sl. No	Descriptions	Qty.	Unit	Rate	Amount
PART A					
1	Supply, Installation, Testing & Commissioning (SITC) of Hi-wall split air-conditioning units (Inverter type) complete as under: - Indoor unit comprising cooling coil, evaporator fan with motor, filters, insulated drain pan etc. - Outdoor unit comprising hermetic compressor, condenser coil with fan & motor, interconnecting refrigeration piping, starters/ controls/ cutouts/ relays etc., mounted inside a powder coated sheet metal cabinet of 2mm thick, duly treated for corrosion protection. The unit should be 100 % copper condensing coil with Minimum 1 year warranty gas should be R 410,1TR=12000 BTU/HR (All the unit should be 5 Star rating)				
a)	2.0 TR	2	Nos		
2	Supply, Installation, Testing & Commissioning (SITC) of Hi-wall split air-conditioning units (Inverter type) complete as under: - Indoor unit comprising cooling coil, evaporator fan with motor, filters, insulated drain pan etc. - Outdoor unit comprising hermetic compressor, condenser coil with fan & motor, interconnecting refrigeration piping, starters/ controls/ cutouts/ relays etc., mounted inside a powder coated sheet metal cabinet of 2mm thick, duly treated for corrosion protection. The unit should be 100 % copper condensing coil with Minimum 1 year warranty gas should be R 410,1TR=12000 BTU/HR (All the unit should be 5 Star rating)				
a)	1.5 TR Capacity	2	Nos		
			Total - A		
PART B					
1	Providing structural supports for the outdoor units (1 set = 2 brackets) NOTE: The outdoor unit shall not be placed over sunshade or the roof.				
a)	For 2.0/1.5/ 1.0 High wall Units	4	Sets		
2	Supply and erection of additional soft copper refrigeration pipe complete with bends, elbows, supports, insulation for suction line etc.				
a)	1.0/1.5/2TR Hi wall units	17	Rm		
3	Supply and laying of control cabling from the MCB (provided by the electrical agency near the indoor units) to the indoor and outdoor units. The power wiring to the compressor motor, condenser fan motors and the evaporator fan motor shall be with suitably rated copper conductors taken within PVC conduit pipes.				
a)	1.0/1.5/2TR Hi wall units	160	Rm		
4	Supply and laying of drain piping of PVC from the indoor unit to the nearest drain with insulation				

a)	With 20 mm Hard PVC pipe	28	Rm		
5	Supply and fixing of suitably rated wall mounted copper wound double booster stabilizer for the above units:				
a)	1.5 TR units (4000 VA):	2	Nos		
b)	2.0 TR units (5000 VA):	2	Nos		
			Total - B		
	TOTAL				

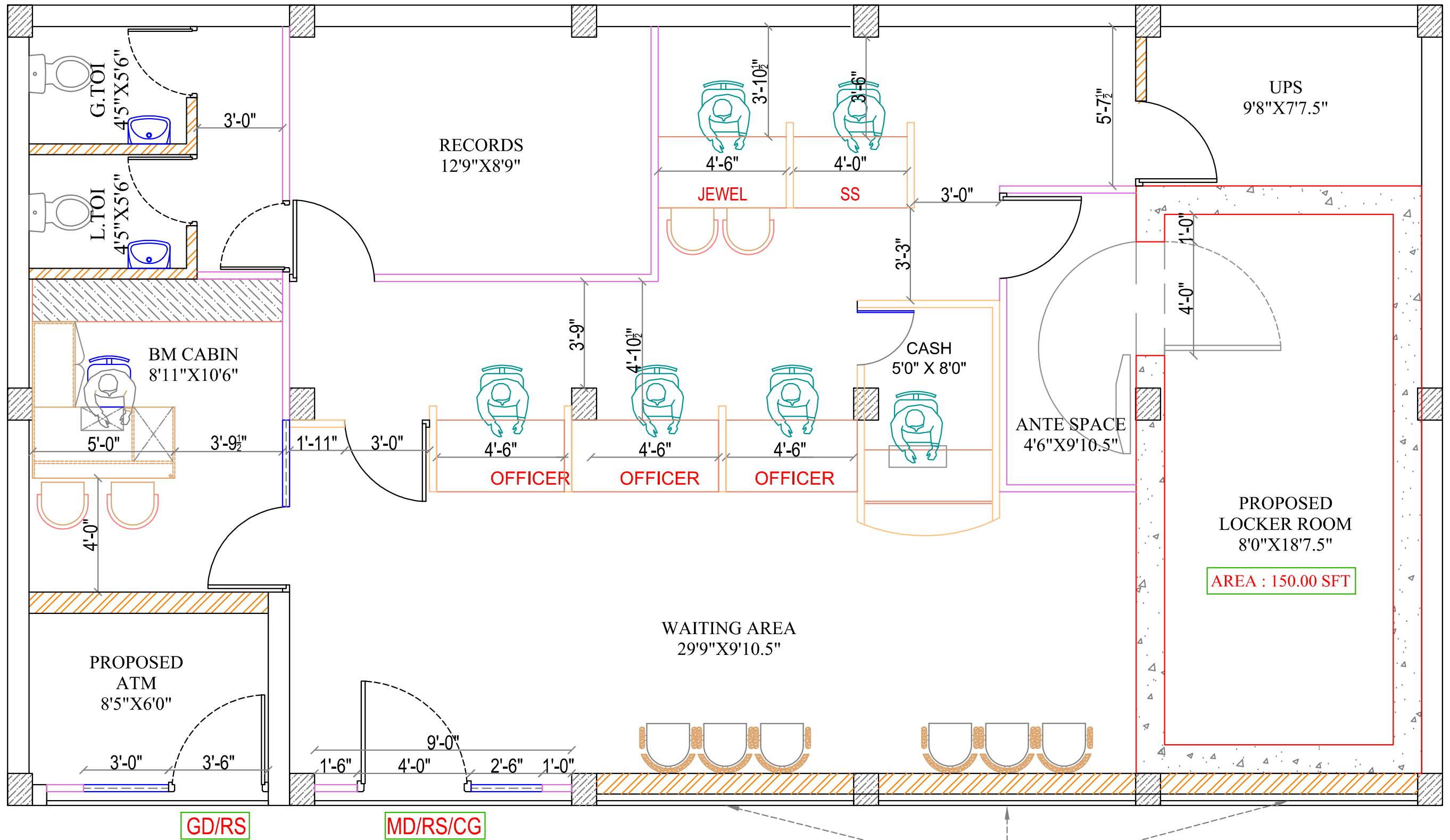

TRUE CEILING HT - 9.6'
 BEAM BOTTOM - 8'11"

CARPET AREA:
 BRANCH - 1224 SFT

GD/RS

MD/RS/CG

EX. ROLLING SHUTTER
 TO BE REMOVED

JOB NO	PROJECT TITLE :	DRAWING TITLE :	DESIGN STAGE	SCALE	N.T.S	DRG NO	SCH-01	ORIENTATION	ARCHITECTS
1676	PROPOSED INTERIOR LAYOUT FOR BANK OF BARODA - KOTAIYUR CHENNAI.	INTERIOR LAYOUT - GROUND	SCHEME LEVEL	DATE	04.03.2024	DRN	D.M		
		WORKING DRAWING	FINAL COPY	R.DATE	-	CHKD	K.S		
<p>NEW NO.16,(OLD NO.42), Ground floor, South West Boag Road, T.Nagar, Chennai - 600017. Ph: 044-42121922 Telefax : 044 - 2435 0493 E-mail : info@tsdc.com</p>									

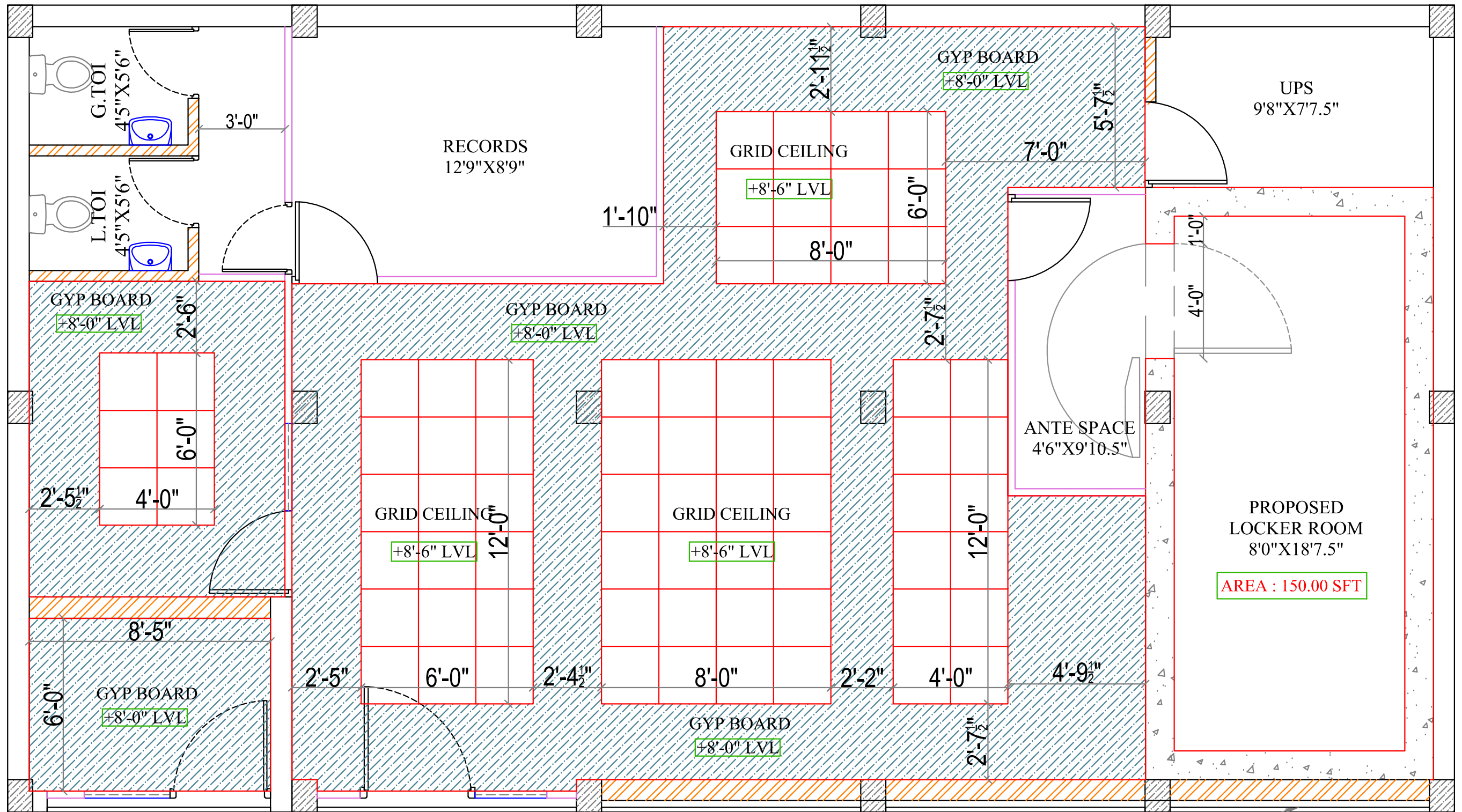

GD/RS

MD/RS/CG

TRUE CEILING HT - 9.6'
 BEAM BOTTOM - 8'11"
 CARPET AREA:
 BRANCH - 1224 SFT

EX. ROLLING SHUTTER
 TO BE REMOVED

17/21

SEAL WITH SIGNATURE OF THE BIDDER

JOB NO	PROJECT TITLE :	DRAWING TITLE :	DESIGN STAGE	SCALE	N.T.S	DRG NO	WOR-02	ORIENTATION	ARCHITECTS
1676	PROPOSED INTERIOR LAYOUT FOR BANK OF BARODA - KOTAIYUR CHENNAI.	FALSE CEILING LAYOUT	SCHEME LEVEL	DATE	04.03.2024	DRN	D.M		
		WORKING DRAWING	FINAL COPY	R.DATE	-	CHKD	K.S		

TSO DESIGN COMMUNE PVT. LTD.
 Architects ■ Planners ■ Interior designers
 NEW NO.16 (OLD NO.42), Ground floor, South West Boag Road,
 T.Nagar, Chennai - 600017. Ph: 044-42121922
 Telefax : 044 - 2435 0493 E-mail : info@tsodc.com

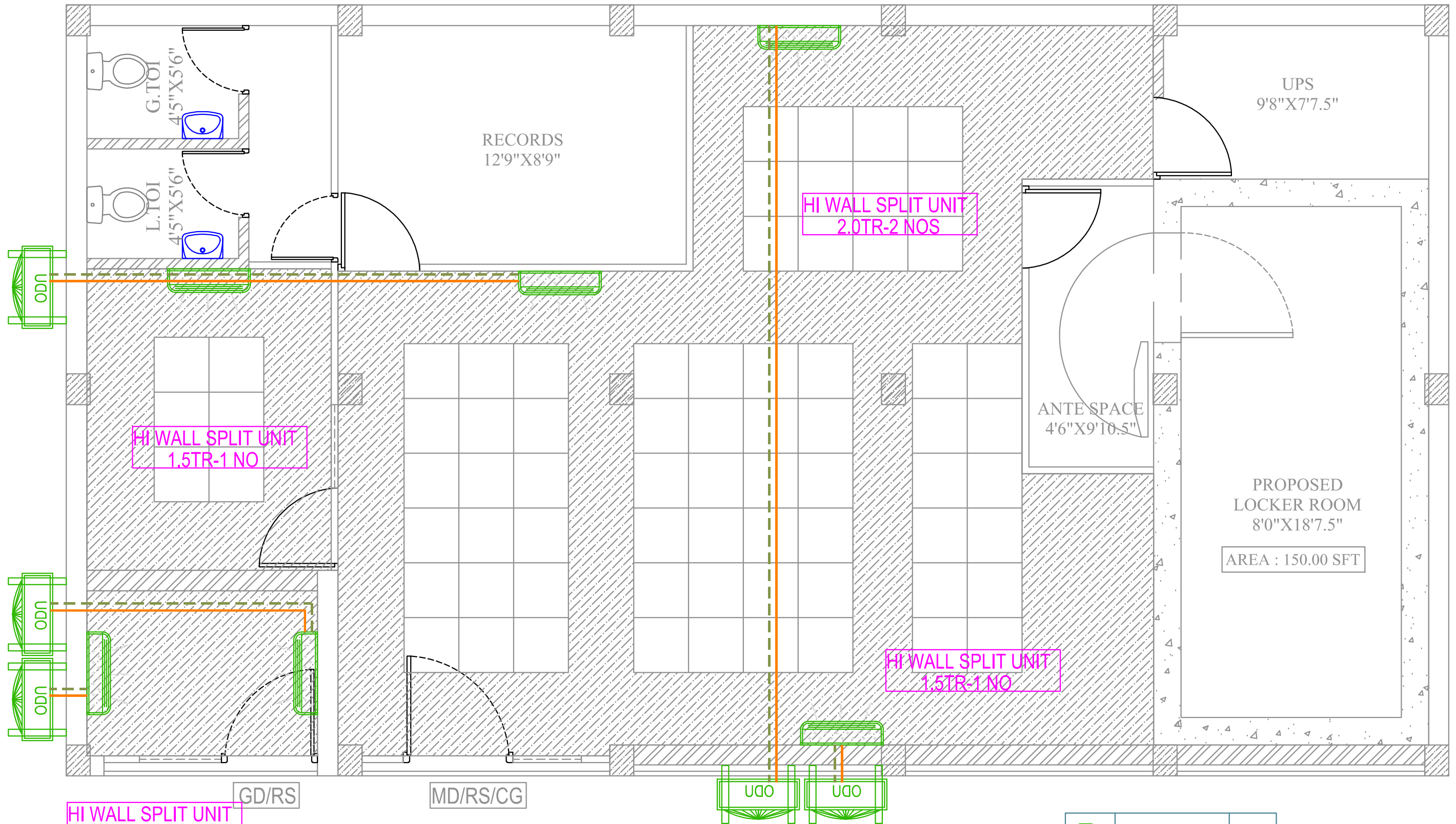

AREA : 150.00 SFT

	PROPOSED SPLIT AC 2.0TR	2 NOS	DRAIN PIPE LINE COPPER PIPE LINE
	PROPOSED SPLIT AC 1.5TR	4 NOS	

18/21 SEAL WITH SIGNATURE OF THE BIDDER

JOB NO	PROJECT TITLE : PROPOSED INTERIOR LAYOUT FOR BANK OF BARODA - KOTAIYUR CHENNAI.	DRAWING TITLE :	AC LAYOUT	DESIGN STAGE	SCALE	N.T.S	DRG NO	WOR-03	ORIENTATION	ARCHITECTS TSO DESIGN COMMUNE PVT. LTD. Architects ■ Planners ■ Interior designers <small>NEW NO.16,(OLD NO.42), Ground floor, South West Boag Road, T.Nagar, Chennai - 600017. Ph: 044-42121922 Telefax : 044 - 2435 0493 E-mail : info@tsodc.com</small>
1676		DRAWING TYPE :	WORKING DRAWING	SCHEME LEVEL FINAL COPY	DATE	04.03.2024	DRN	D.M		
				R.DATE	-	CHKD	K.S			

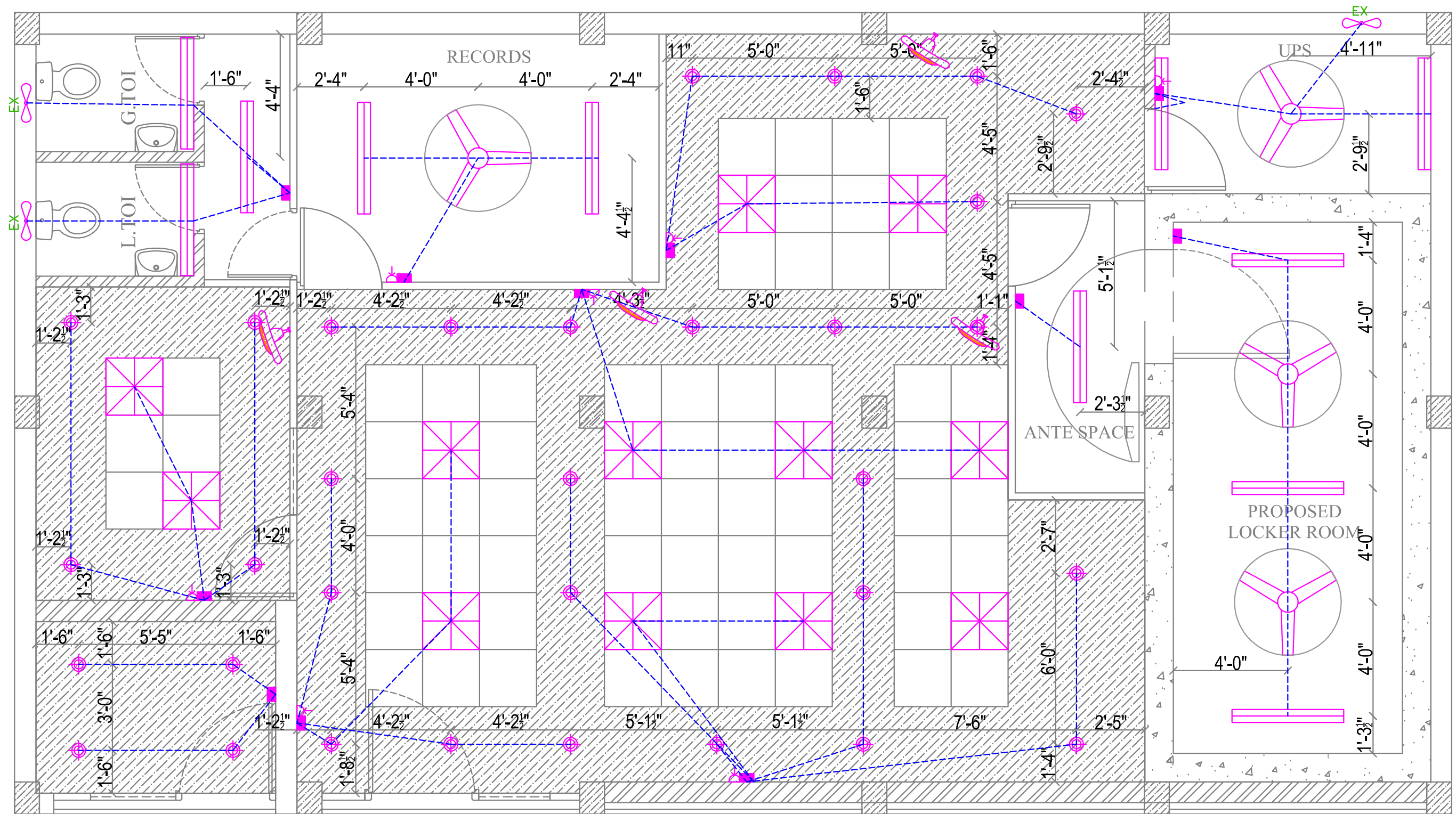

LEGEND

	2' X 2' - 36 W LED FITTING
	15 W LED DOWN LIGHT
	4' - 1 x 21 W LED Fitting
	WALL MOUNTING FAN
	CEILING FAN
	EXHAUST FAN
	CEILING SPEAKER
	SWITCH BOX
	SWITCH BOX WITH 6A SOCKET

GD/RS

MD/RS/CG

19/21

SEAL WITH SIGNATURE OF THE BIDDER

JOB NO	PROJECT TITLE : PROPOSED INTERIOR LAYOUT FOR BANK OF BARODA - KOTAIYUR CHENNAI.	DRAWING TITLE :	LIGHTING LAYOUT	DESIGN STAGE	SCALE	N.T.S	DRG NO	ELEC - 01	ORIENTATION	ARCHITECTS TSO DESIGN COMMUNE PVT. LTD. Architects ■ Planners ■ Interior designers <small>NEW NO.16,(OLD NO.42), Ground floor, South West Boag Road, T.Nagar, Chennai - 600017. Ph: 044-42121922 Telefax : 044 - 2435 0493 E-mail : info@tsodc.com</small>
1676		DRAWING TYPE :	WORKING DRAWING			DATE	06.03.2024	DRN	HARI	
						R.DATE	-	CHKD	G.G	

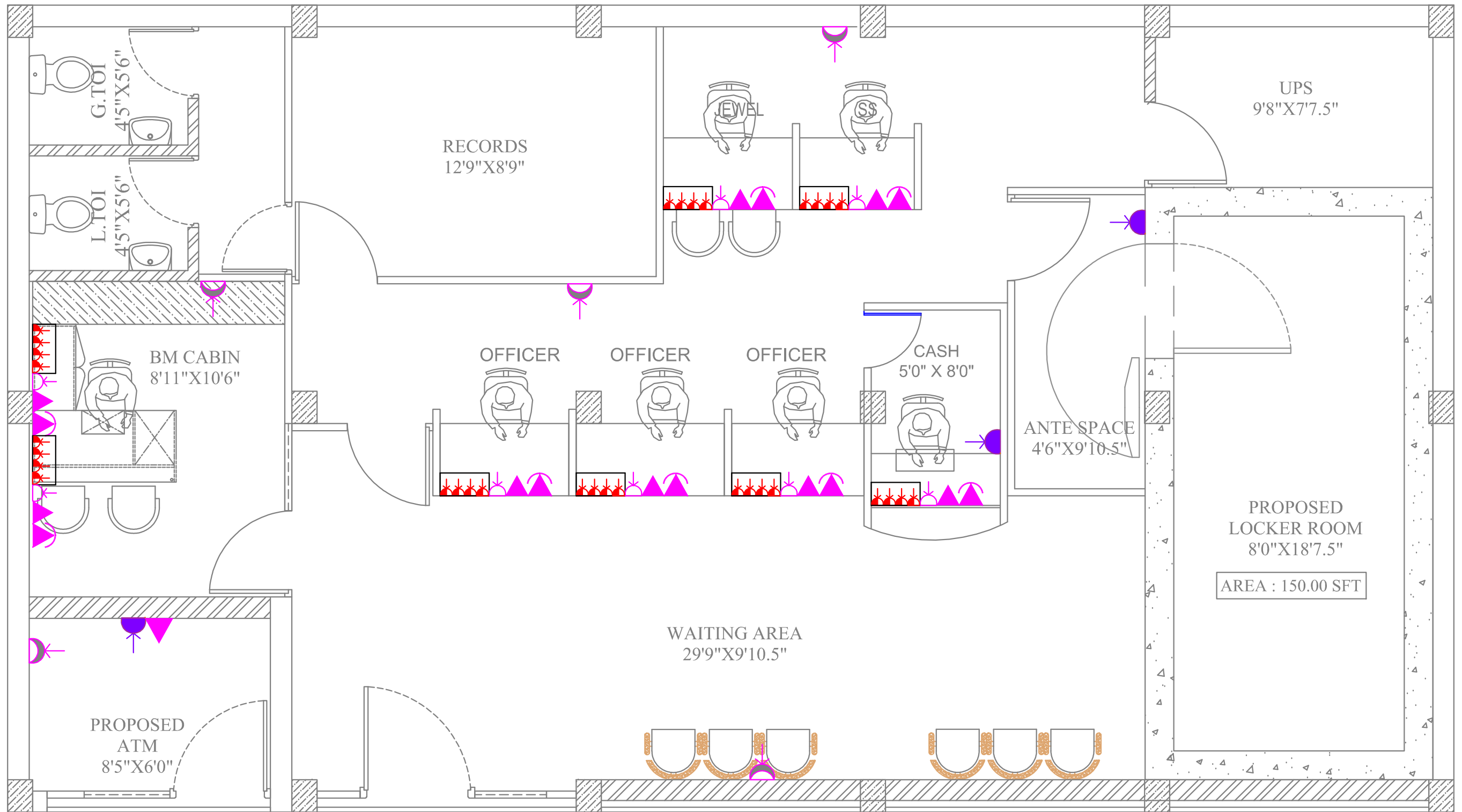

LEGEND	
	4 Nos. 6A UPS Power Socket Outlet
	2 Nos. 6A RAW Power Socket Outlet
	1 Nos. 5A Raw Power Socket Outlet
	Modular Type 25/32A A/C Socket
	6/16A Raw Power Socket Outlet
	Data Socket
	Telephone Outlet
	Distribution Board

GD/RS

MD/RS/CG

20/21

SEAL WITH SIGNATURE OF THE BIDDER

JOB NO	PROJECT TITLE : PROPOSED INTERIOR LAYOUT FOR BANK OF BARODA - KOTAIYUR CHENNAI.	DRAWING TITLE :	POWER LAYOUT - GROUND	DESIGN STAGE	SCALE	N.T.S	DRG NO	ELEC - 02	ORIENTATION	ARCHITECTS TSO DESIGN COMMUNE PVT. LTD. Architects ■ Planners ■ Interior designers <small>NEW NO.16,(OLD NO.42), Ground floor, South West Boag Road, T.Nagar, Chennai - 600017, Ph : 044-4212 8252 Telefax : 044 - 2435 0493 E-mail : info@tsodc.com</small>
1676		DRAWING TYPE :	WORKING DRAWING	SCHEME LEVEL	DATE	06.03.2024	DRN	HARI		
				FINAL COPY	R.DATE	-	CHKD	G.G		

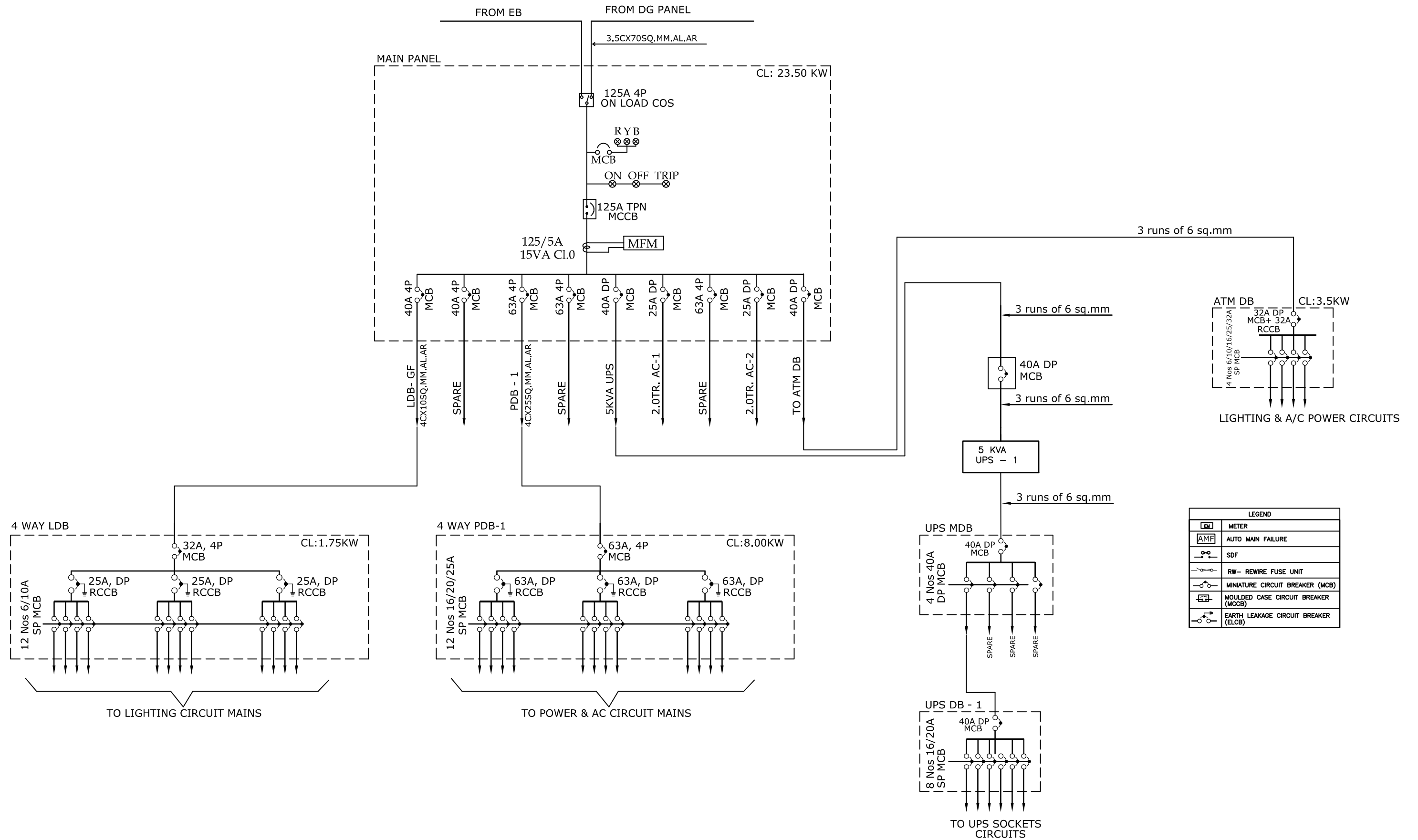

21/21

SEAL WITH SIGNATURE OF THE BIDDER

JOB NO	PROJECT TITLE : PROPOSED INTERIOR LAYOUT FOR BANK OF BARODA - KOTAIYUR CHENNAI.	DRAWING TITLE :	SINGLE LINE DIAGRAM	DESIGN STAGE	SCALE	N.T.S	DRG NO	ELEC - 03	ORIENTATION	ARCHITECTS TSO DESIGN COMMUNE PVT. LTD. Architects ■ Planners ■ Interior designers NEW NO.16 (OLD NO.42), Ground floor, South West Boag Road, T.Nagar, Chennai - 600017, Ph: 044-42121922 Telefax : 044 - 2435 0493 E-mail : info@tsodc.com
1676		DRAWING TYPE :	WORKING DRAWING	<input type="checkbox"/> SCHEME LEVEL <input checked="" type="checkbox"/> FINAL COPY	DATE	06.03.2024	DRN	HARI		
				R.DATE	-	CHKD	G.G			